

Cyberfortifying CPS through Security-by-Design

Keynote – IEEE Conference on Secure and Trustworthy CyberInfrastructure for IoT and Microelectronics (SaTC 2025)

<https://satcconf.com/>

Dayton, Ohio – 25 Feb 2025



Homepage:
www.smohanty.org

Prof./Dr. Saraju Mohanty
University of North Texas, USA.



Outline

- IoT/CPS – Big Picture
- Challenges in IoT/CPS Design
- Cybersecurity Solution for IoT/CPS
- Drawbacks of Existing Cybersecurity Solutions
- Security-by-Design (SbD) – The Principle
- Security-by-Design (SbD) - Specific Examples
- Is Physical Unclonable Function (PUF) a Solution for All Cybersecurity Problems?
- Is Blockchain a Solution for All Cybersecurity Problems?
- Conclusion

The Big Picture

IoT → CPS → Smart Cities or Smart Villages

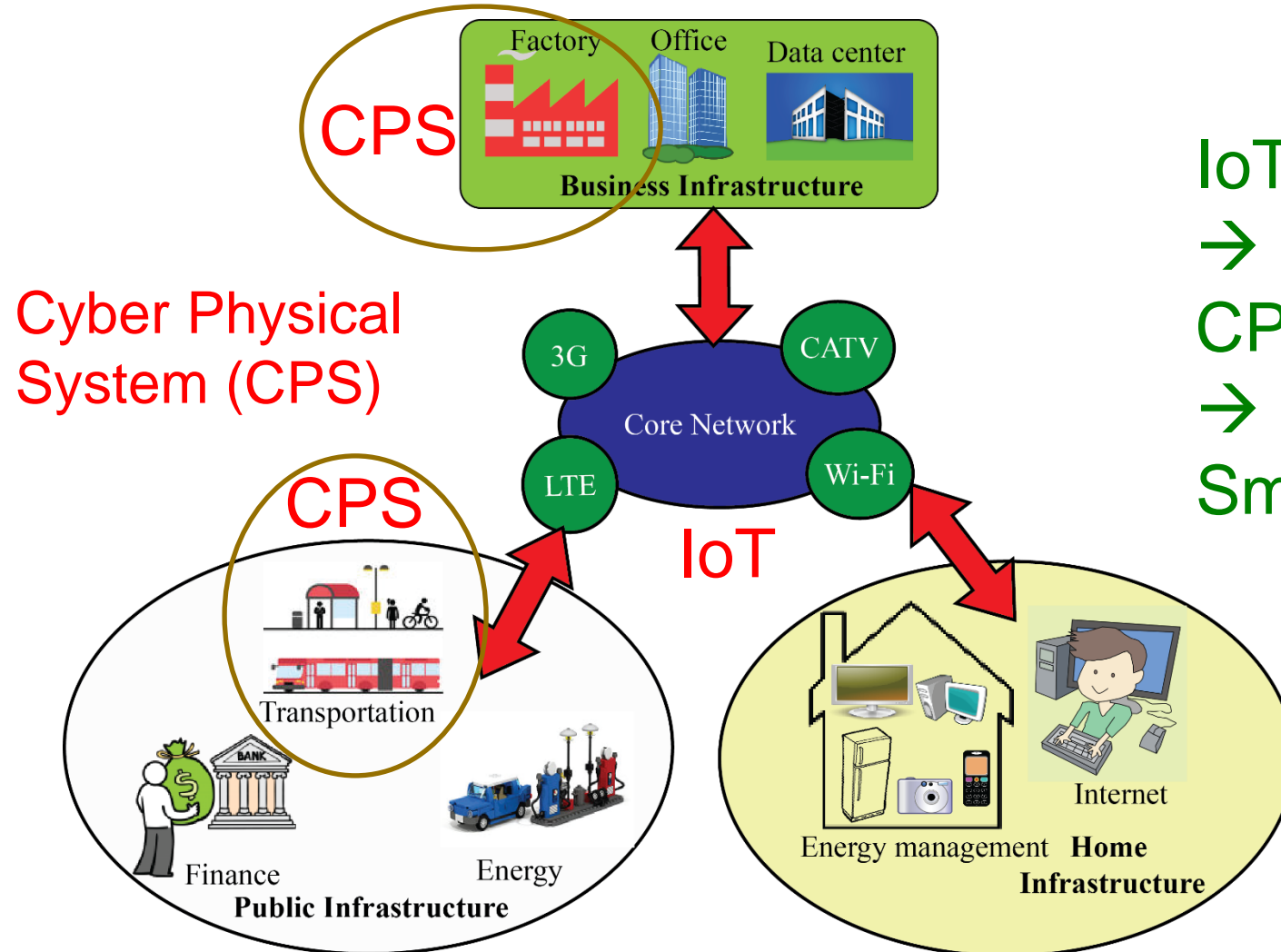

IoT
→
CPS (Smart Components)
→
Smart Cities or Smart Villages

IoT is the backbone

Source: S. P. Mohanty, U. Choppali, and E. Kougianos, "Everything You wanted to Know about Smart Cities", *IEEE Consumer Electronics Magazine*, Vol. 5, No. 3, July 2016, pp. 60--70.

Healthcare Cyber-Physical System (H-CPS)

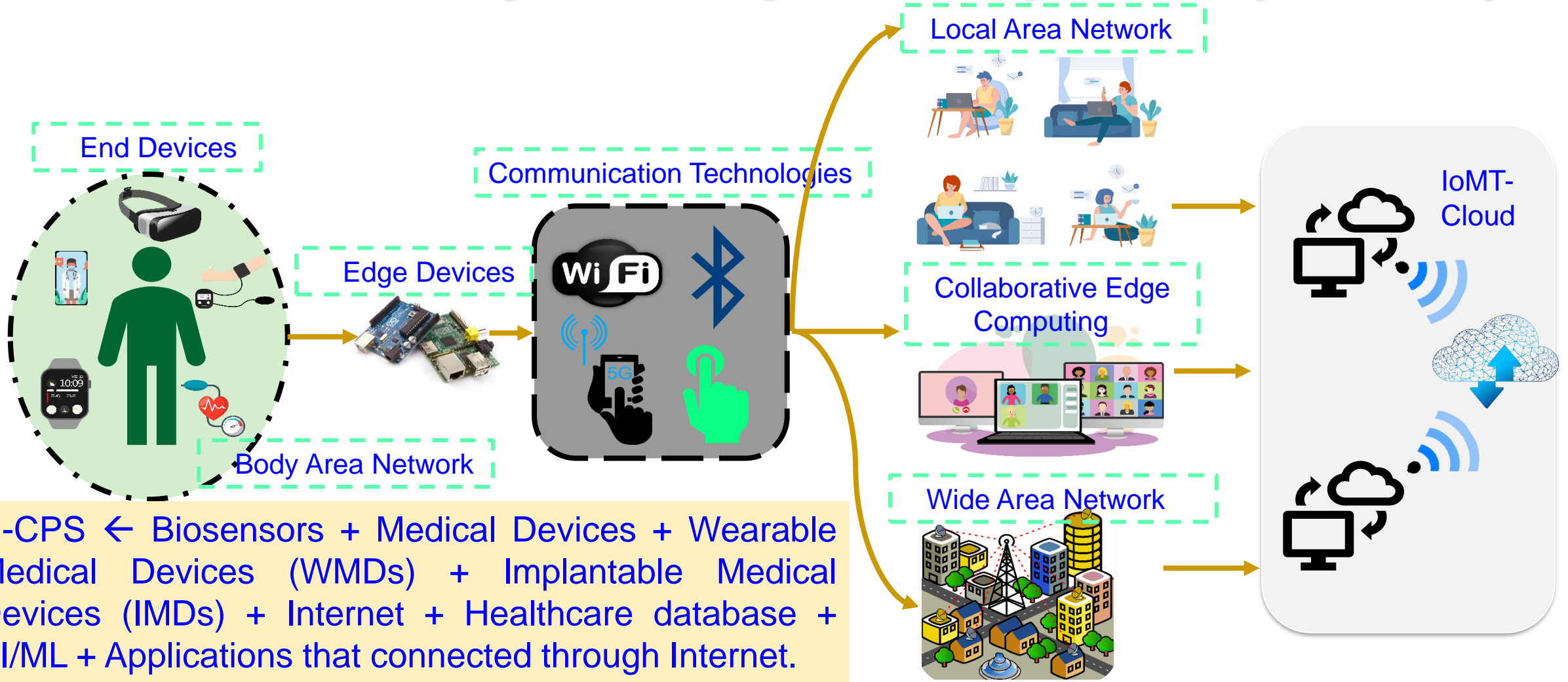

H-CPS ← Biosensors + Medical Devices + Wearable Medical Devices (WMDs) + Implantable Medical Devices (IMDs) + Internet + Healthcare database + AI/ML + Applications that connected through Internet.

Frost and Sullivan predicts smart healthcare market value to reach US\$348.5 billion by 2025.

Agriculture Cyber-Physical System (A-CPS)

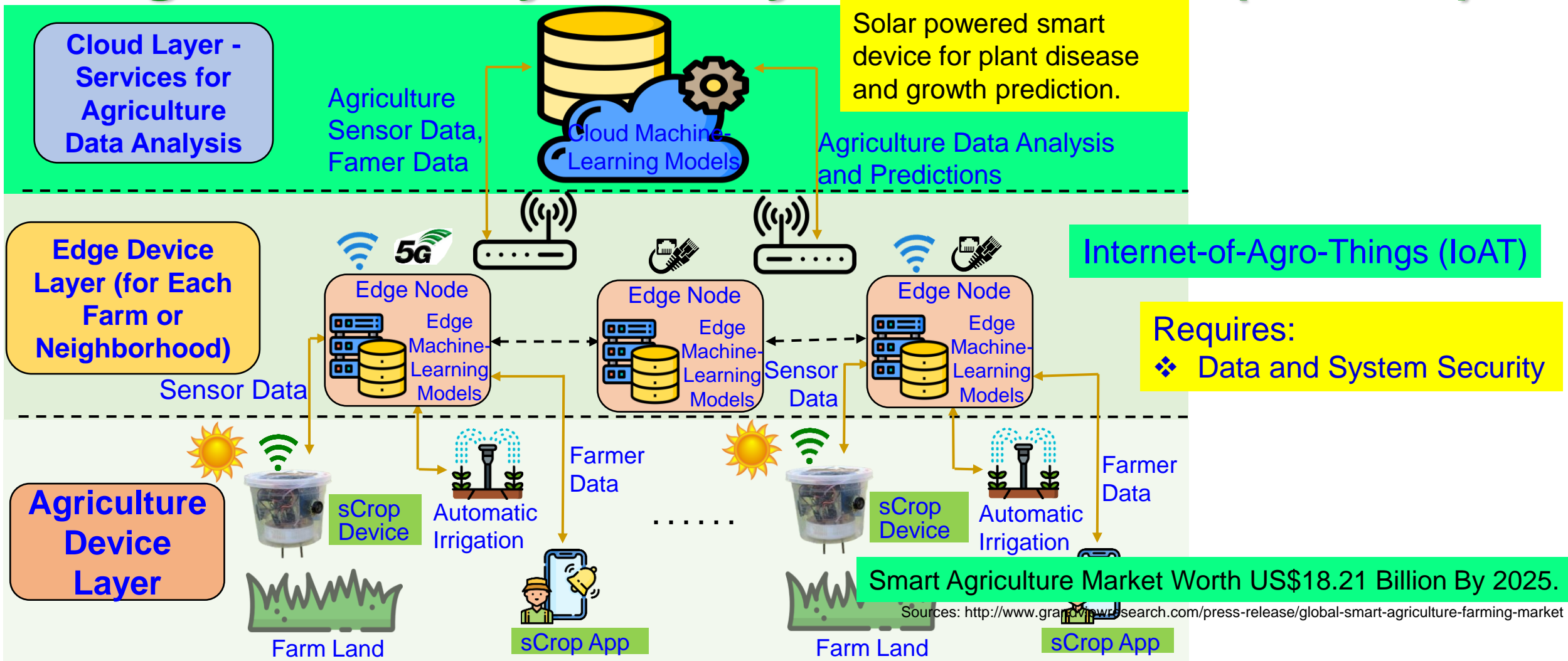

Source: V. Udutalappally, S. P. Mohanty, V. Pallagani, and V. Khandelwal, "sCrop: A Novel Device for Sustainable Automatic Disease Prediction, Crop Selection, and Irrigation in Internet-of-Agro-Things for Smart Agriculture", *IEEE Sensors Journal*, Vol. 21, No. 16, August 2021, pp. 17525--17538, DOI: 10.1109/JSEN.2020.3032438.

Energy Cyber-Physical System (E-CPS)

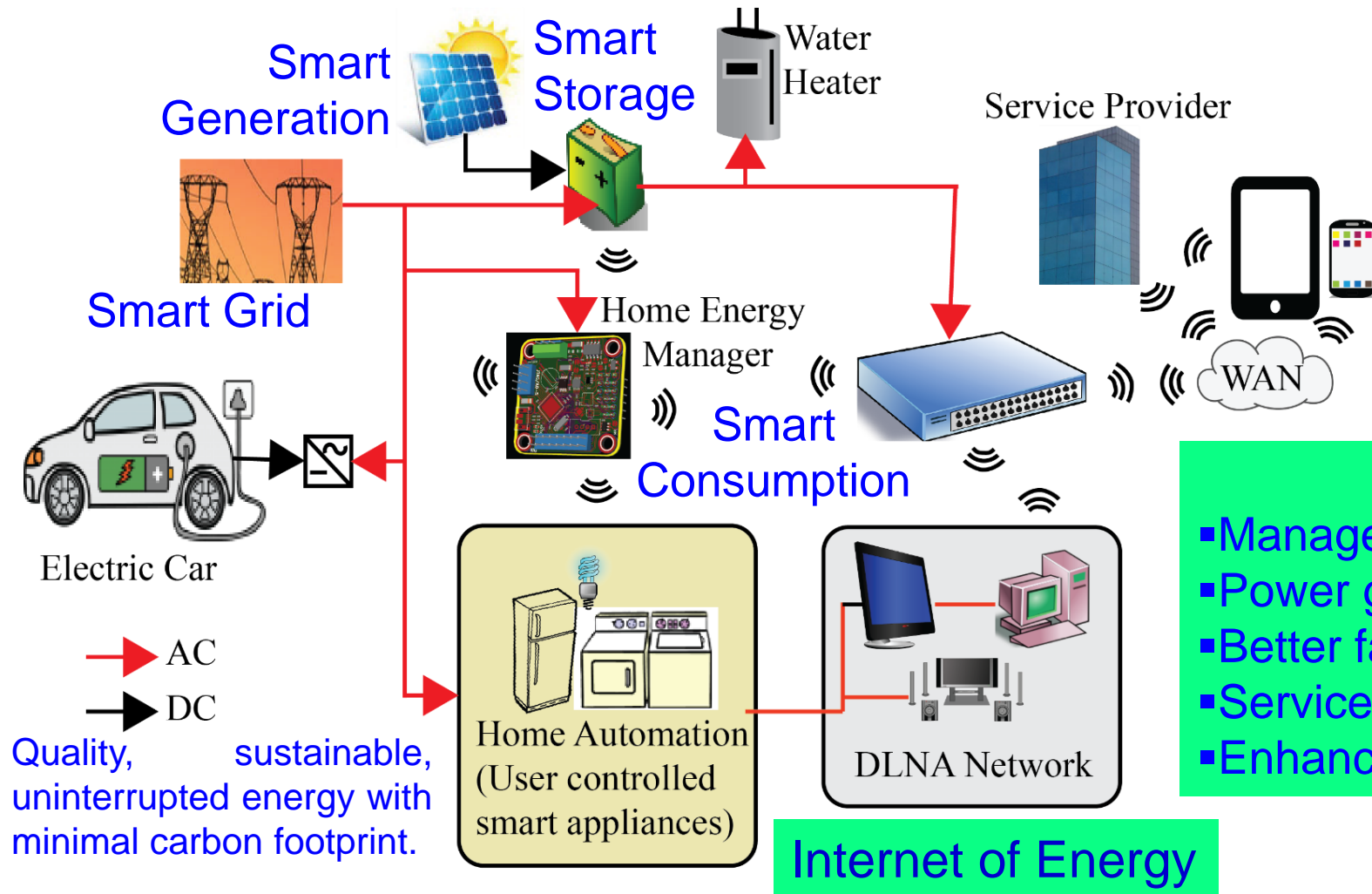

Requires:

- ❖ Data, Device, and System Security

IoT Role:

- Management of energy usage
- Power generation dispatch for solar, wind, etc.
- Better fault-tolerance of the grid
- Services for plug-in electric vehicles (PEV)
- Enhancing consumer relationships

Quality, sustainable, uninterrupted energy with minimal carbon footprint.

Internet of Energy

Source: S. P. Mohanty, U. Choppali, and E. Kougianos, "Everything You wanted to Know about Smart Cities", *IEEE Consumer Electronics Magazine*, Vol. 5, No. 3, July 2016, pp. 60--70.

Challenges in IoT/CPS Design



IoT/CPS – Selected Challenges

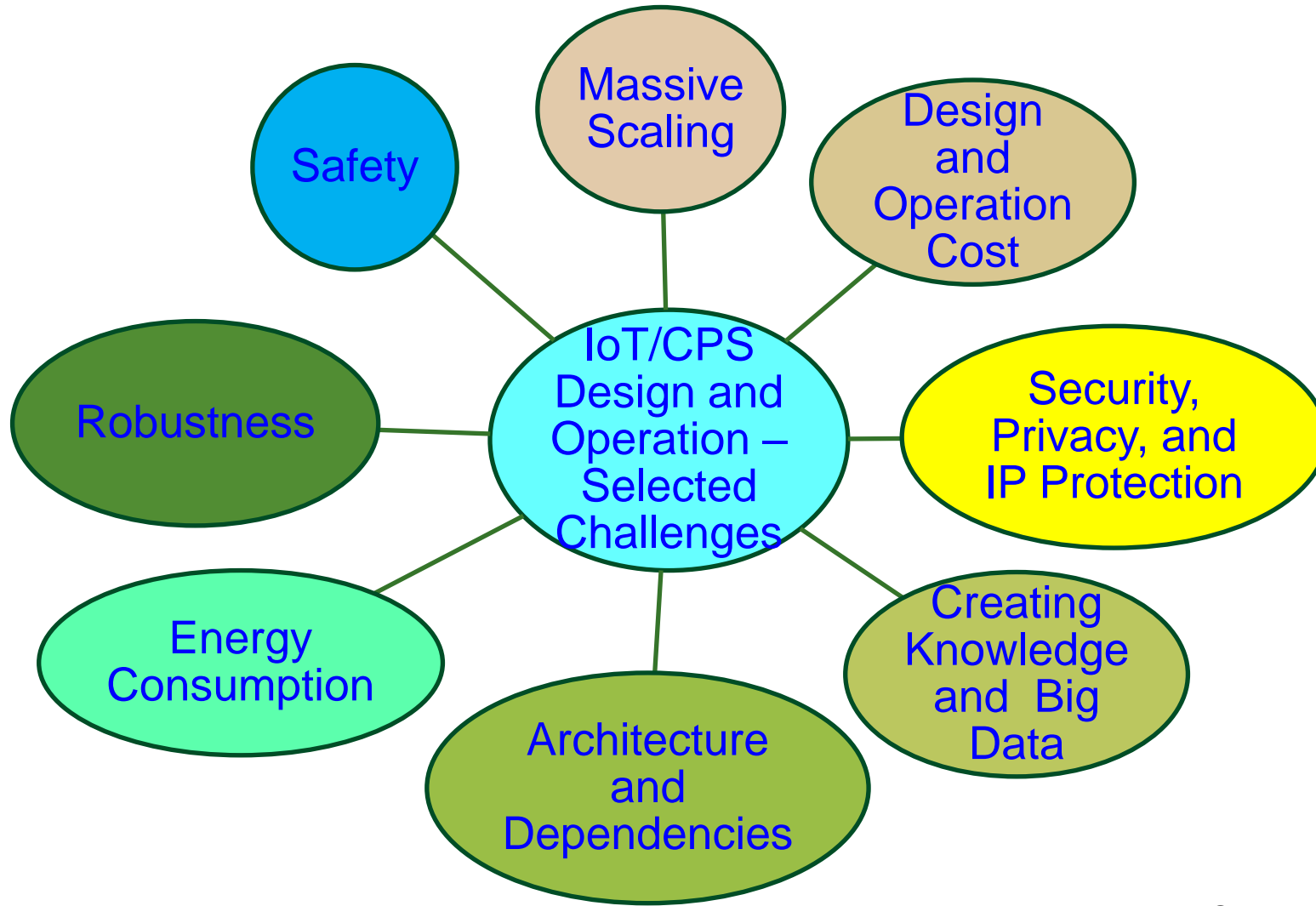

Source: Mohanty ICIT 2017 Keynote

Cybersecurity Challenges - System

Power Grid Attack



Source: <http://www.csoonline.com/article/3177209/security/why-the-ukraine-power-grid-attacks-should-raise-alarm.html>

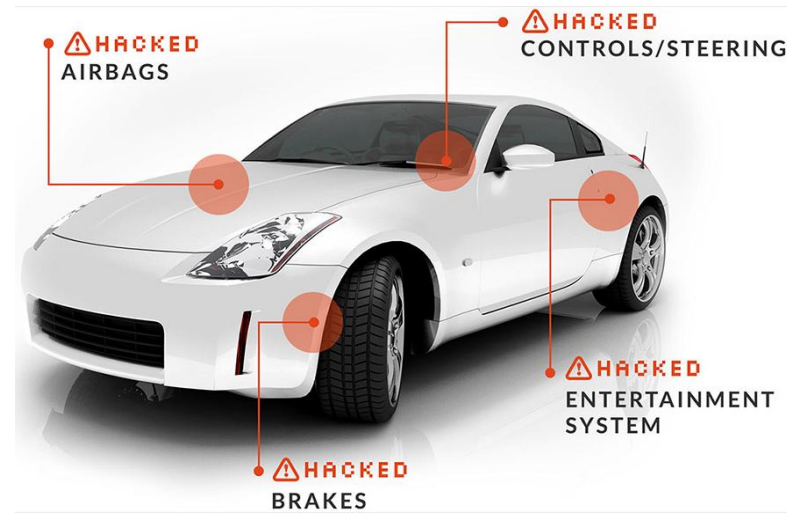

Source: <http://money.cnn.com/2014/06/01/technology/security/car-hack/>



Source: <http://politicalblindspot.com/u-s-drone-hacked-and-hijacked-with-ease/>

Smart Healthcare - Cybersecurity and Privacy Issue

Selected Smart Healthcare Security/Privacy Challenges

- Data Eavesdropping
- Data Confidentiality
- Data Privacy
- Location Privacy
- Identity Threats
- Access Control
- Unique Identification
- Data Integrity
- Device Security

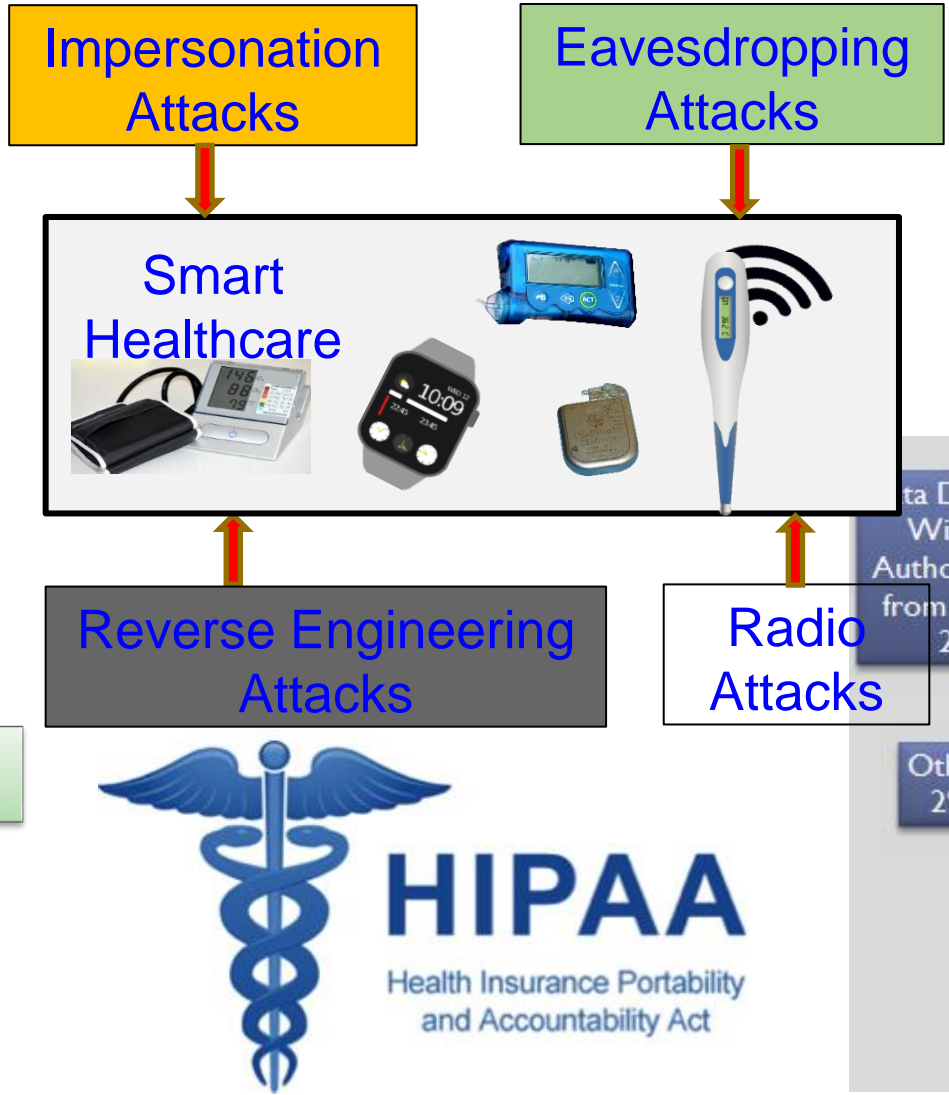

HIPPA Privacy Violation by Types

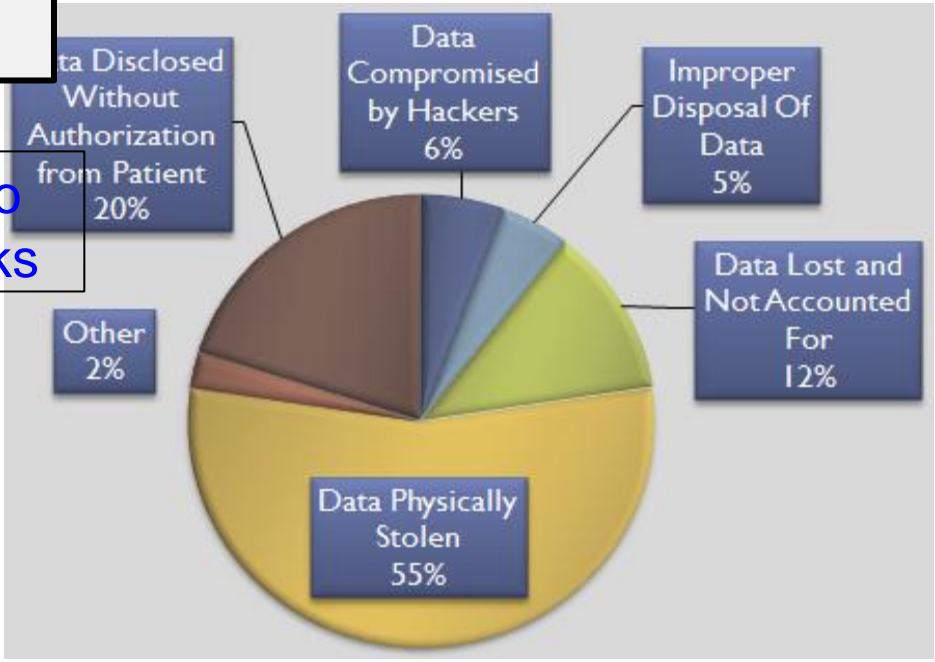

Internet of Agro-Things (IoAT) - Cybersecurity Issue

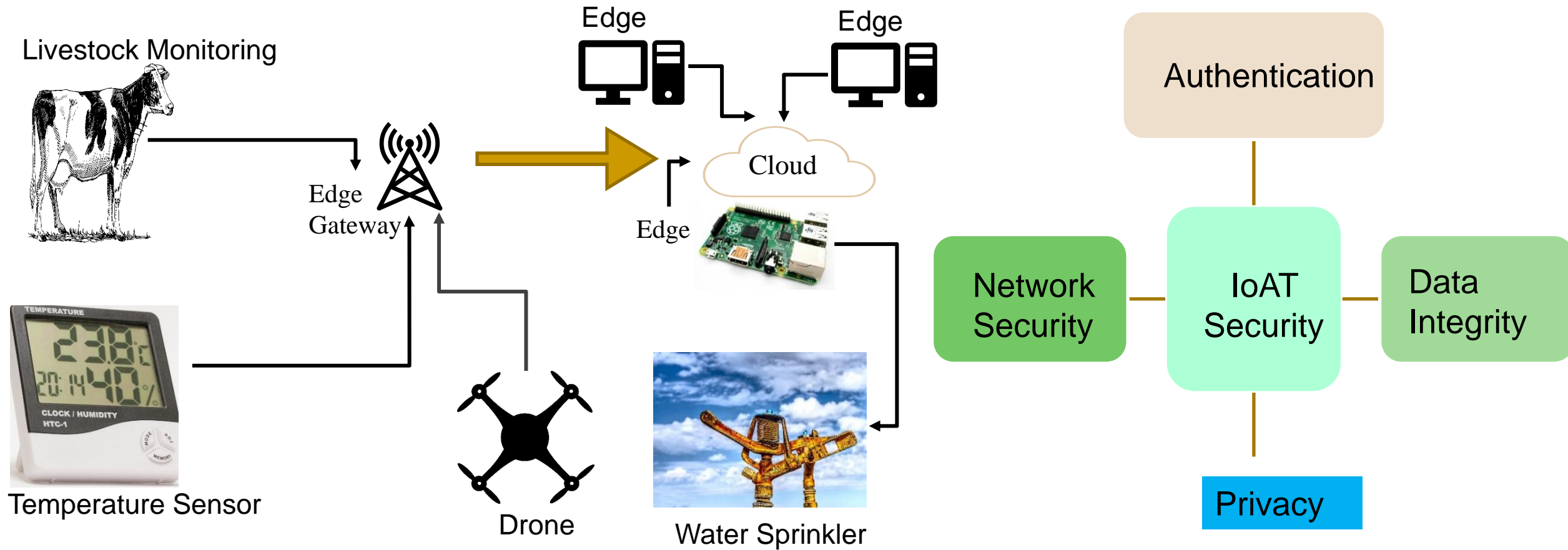

Source: V. K. V. V. Bathalapalli, S. P. Mohanty, E. Kougianos, V. P. Yanambaka, B. K. Baniya and B. Rout, "A PUF-based Approach for Sustainable Cybersecurity in Smart Agriculture," in *Proc. 19th OITS International Conference on Information Technology (OCIT)*, 2021, pp. 375-380, doi: 10.1109/OCIT53463.2021.00080.

Smart Grid - Vulnerability

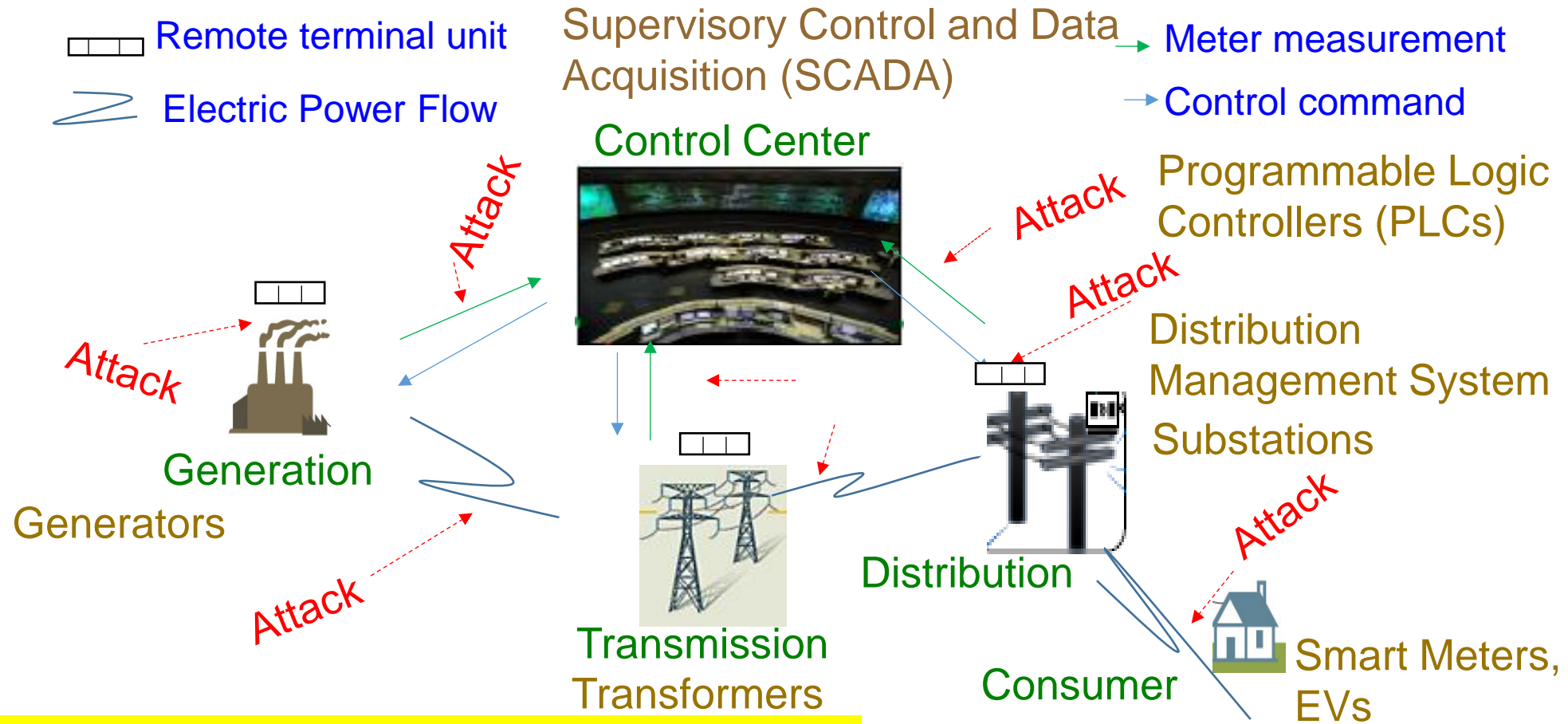

ICT components of smart grid is cyber vulnerable.

Source: (1) R. K. Kaur, L. K. Singh and B. Pandey, "Security Analysis of Smart Grids: Successes and Challenges," *IEEE Consumer Electronics Magazine*, vol. 8, no. 2, pp. 10-15, March 2019.
 (2) https://www.enisa.europa.eu/topics/critical-information-infrastructures-and-services/smart-grids/smart-grids-and-smart-metering/ENISA_Annex%20II%20-%20Security%20Aspects%20of%20Smart%20Grid.pdf

AI Security - Attacks

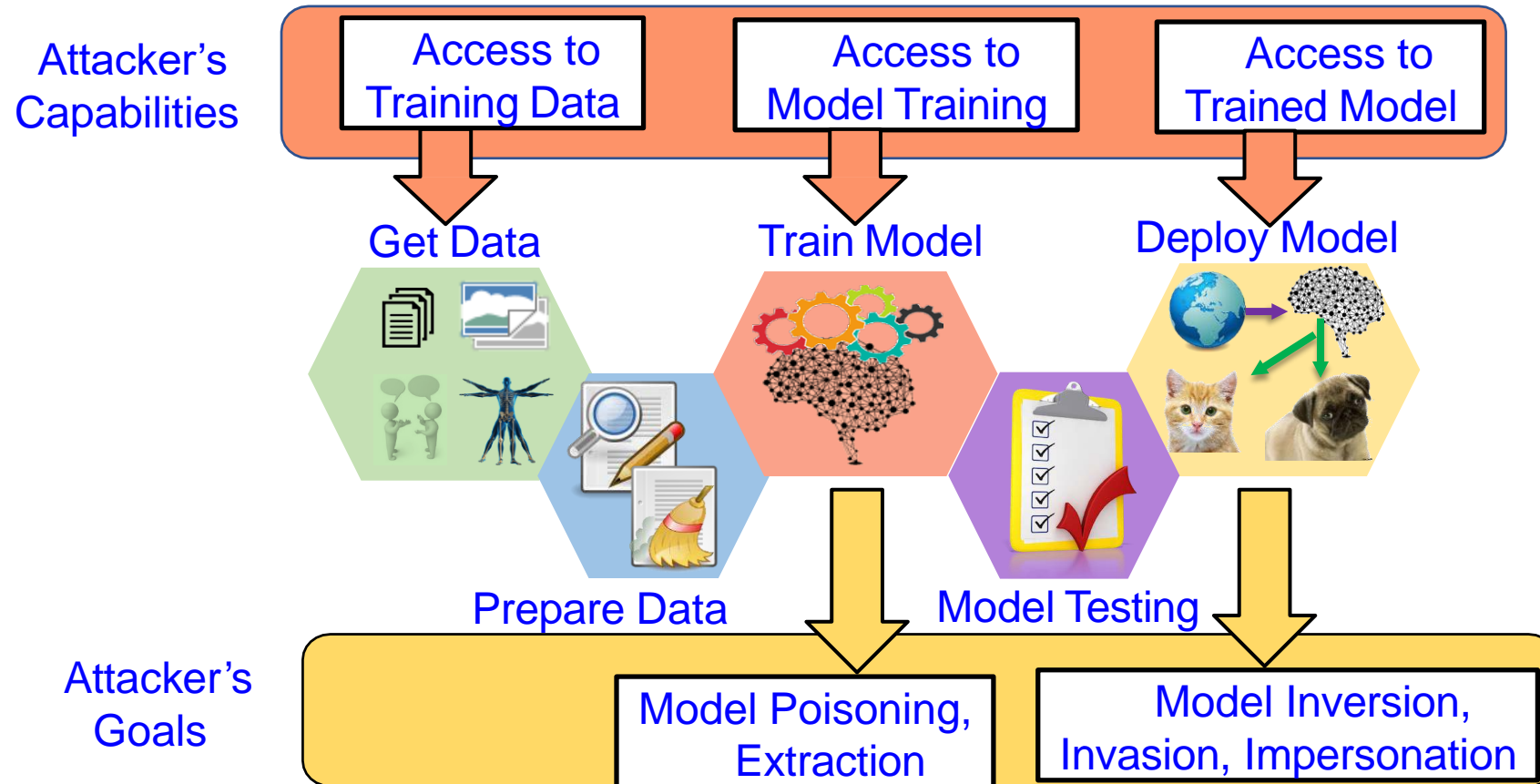

Source: Sandip Kundu ISVLSI 2019 Keynote.

Fake Data and Fake Hardware – Both are Equally Dangerous in CPS



AI can be fooled by fake data



AI can create fake data (Deepfake)

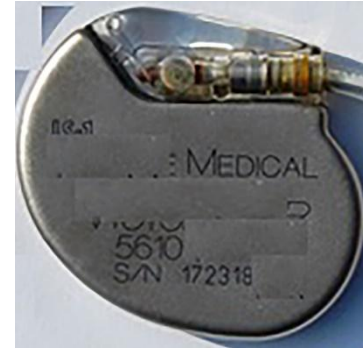

Authentic



Fake

An implantable medical device



Authentic

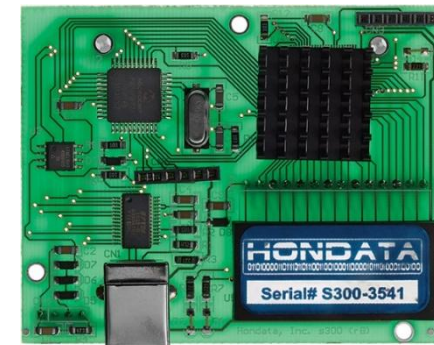

Fake

A plug-in for car-engine computers

Fake is Cheap – Why not Buy?



Is my Pacemaker Authentic or Fake?

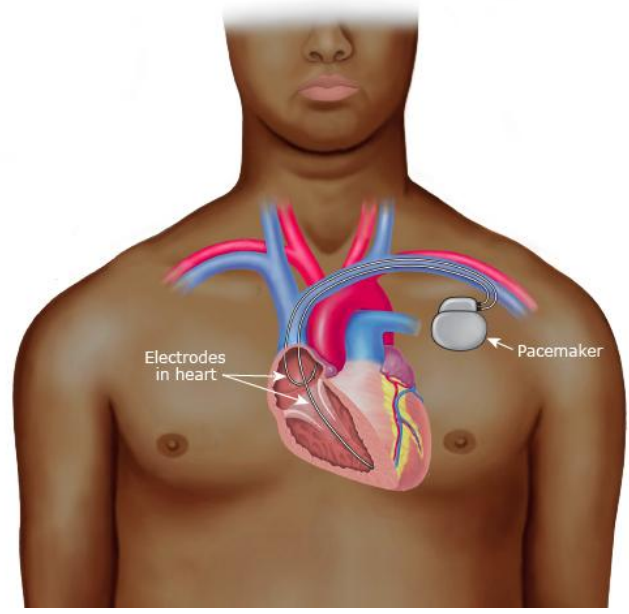

International Pharmaceutical Students' Federation
Asia Pacific Regional Office

THE NEGATIVE IMPACTS OF FAKE MEDICINE

- Increased mortality and morbidity
- Development of drug resistance
- Increase the chance of adverse effects
- Loss of confidence in health systems and health workers
- Undermining of drug research and development
- Crowding out of legitimate drug manufacturers
- Decreased willingness of patients to accept treatment
- Economic loss for patients and health systems

Source: <https://apro.ipssf.org/>

Cybersecurity Solution for IoT/CPS



Our Swing-Pay: NFC Cybersecurity Solution

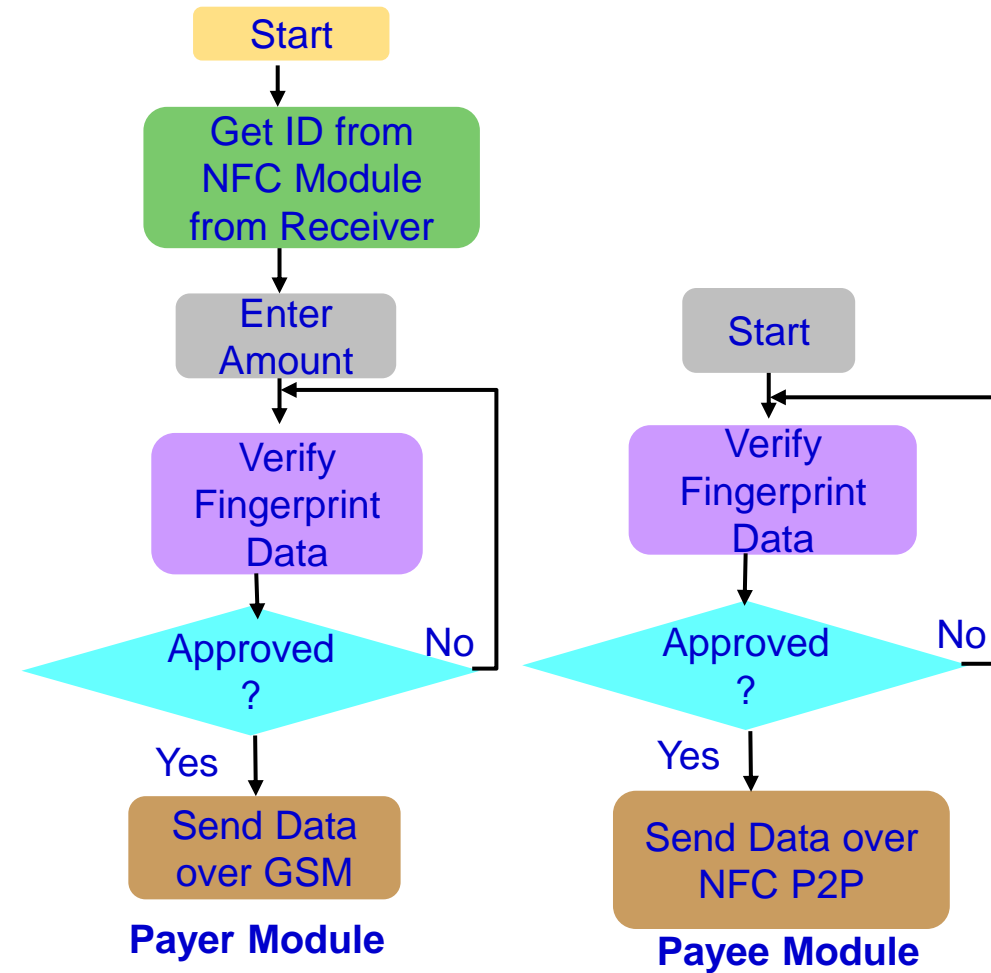
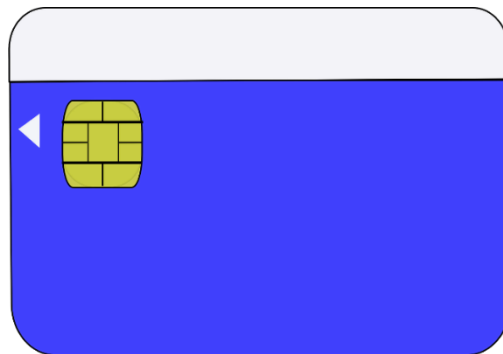
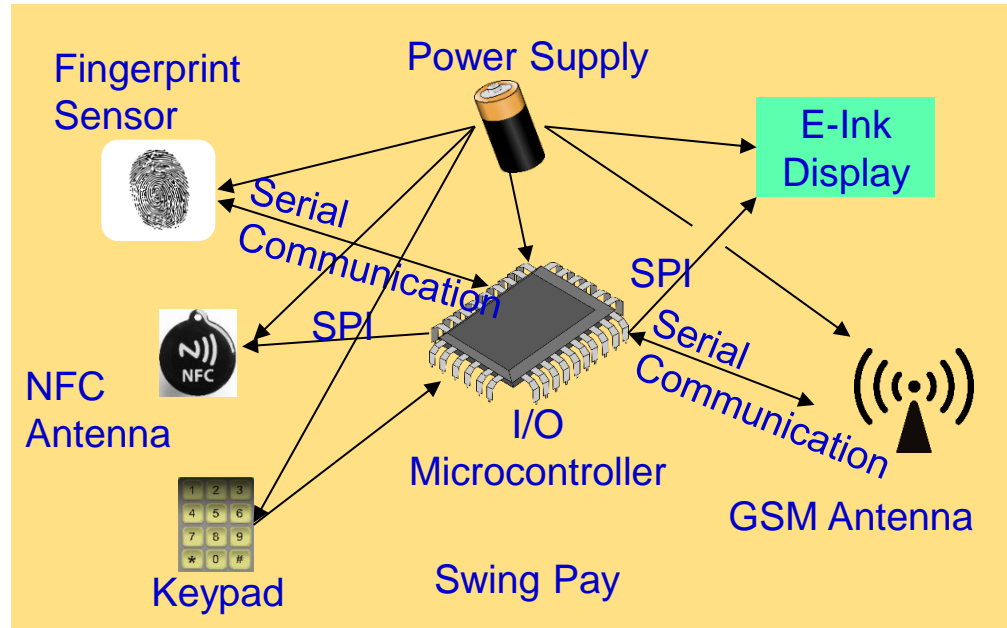

Source: S. Ghosh, J. Goswami, A. Majumder, A. Kumar, **S. P. Mohanty**, and B. K. Bhattacharyya, "Swing-Pay: One Card Meets All User Payment and Identity Needs", *IEEE Consumer Electronics Magazine (MCE)*, Volume 6, Issue 1, January 2017, pp. 82--93.

RFID Cybersecurity - Solutions

Selected RFID Security Methods



Faraday Cage

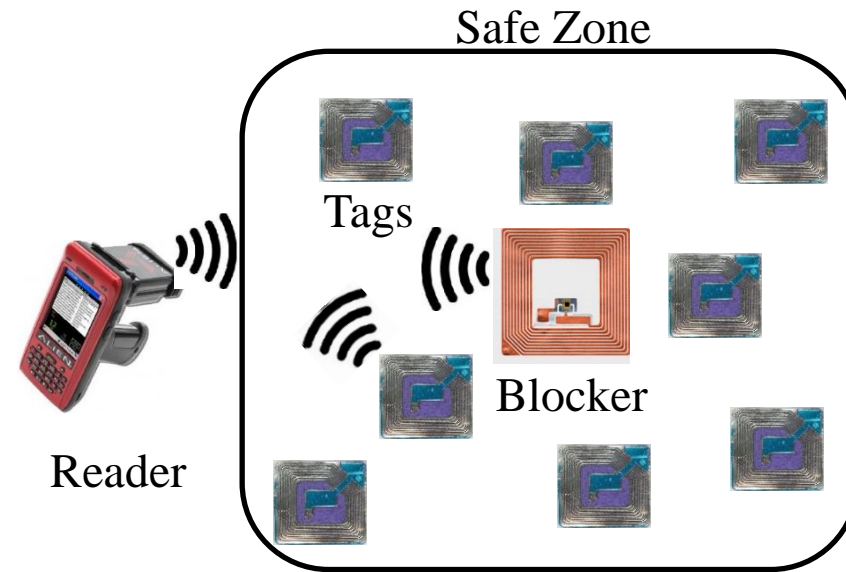
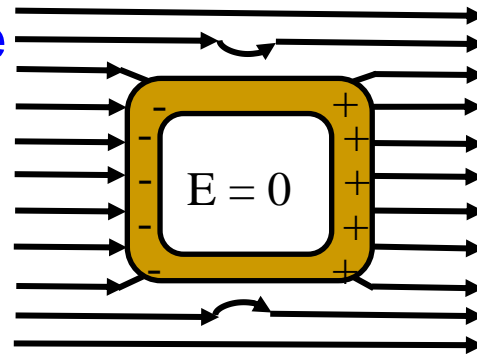

Blocker Tags

Source: Khattab 2017, Springer 2017 RFID Security

Firmware Cybersecurity - Solution

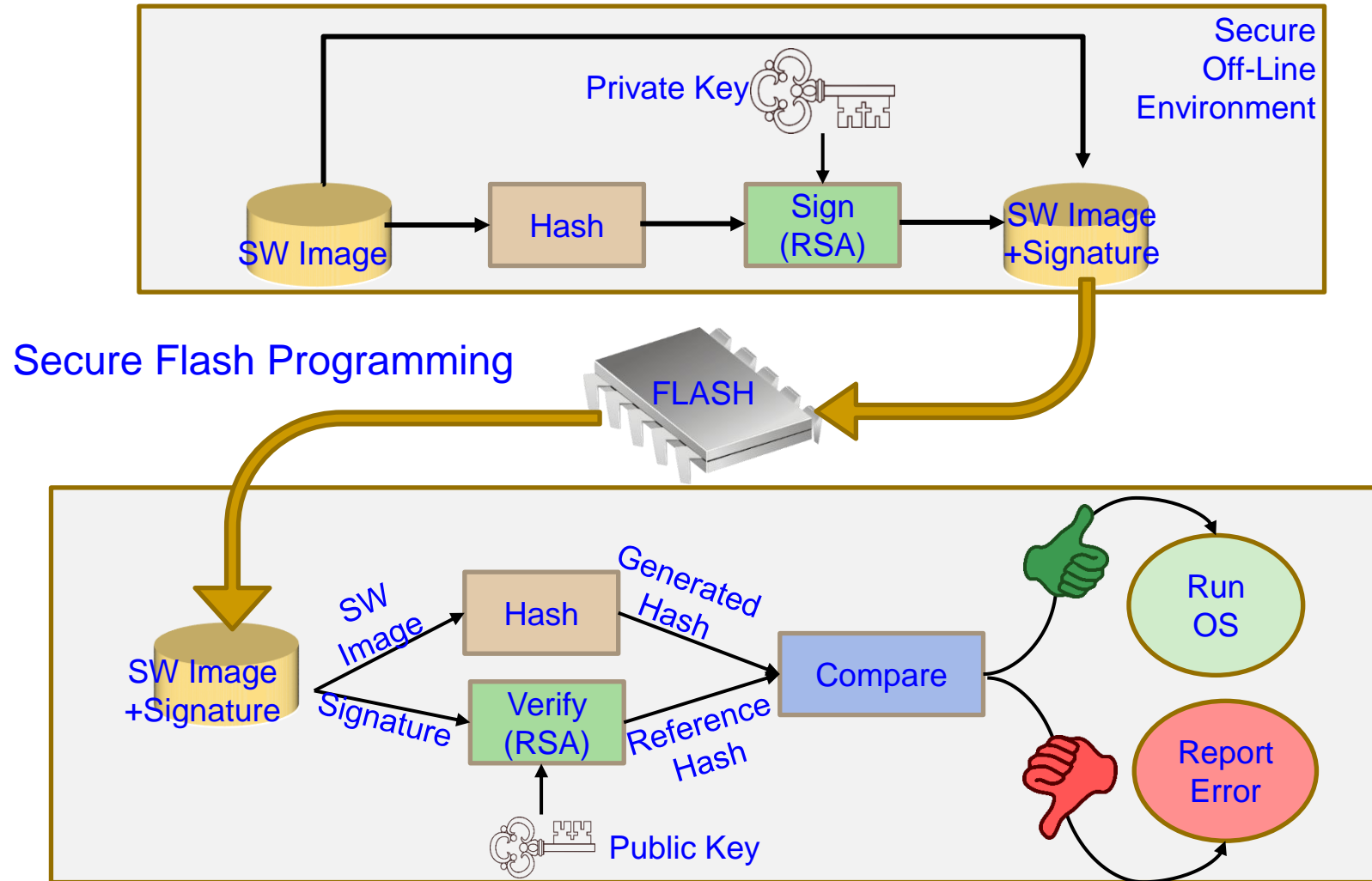

Source: <https://www.nxp.com/docs/en/white-paper/AUTOSECURITYWP.pdf>

Embedded Memory Security

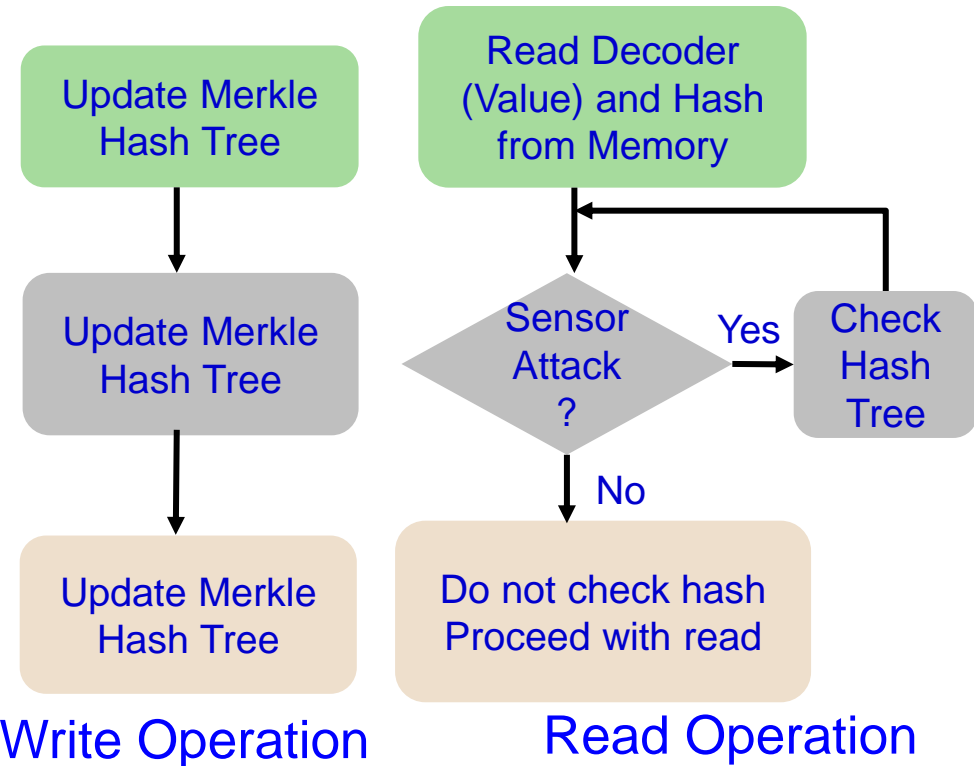
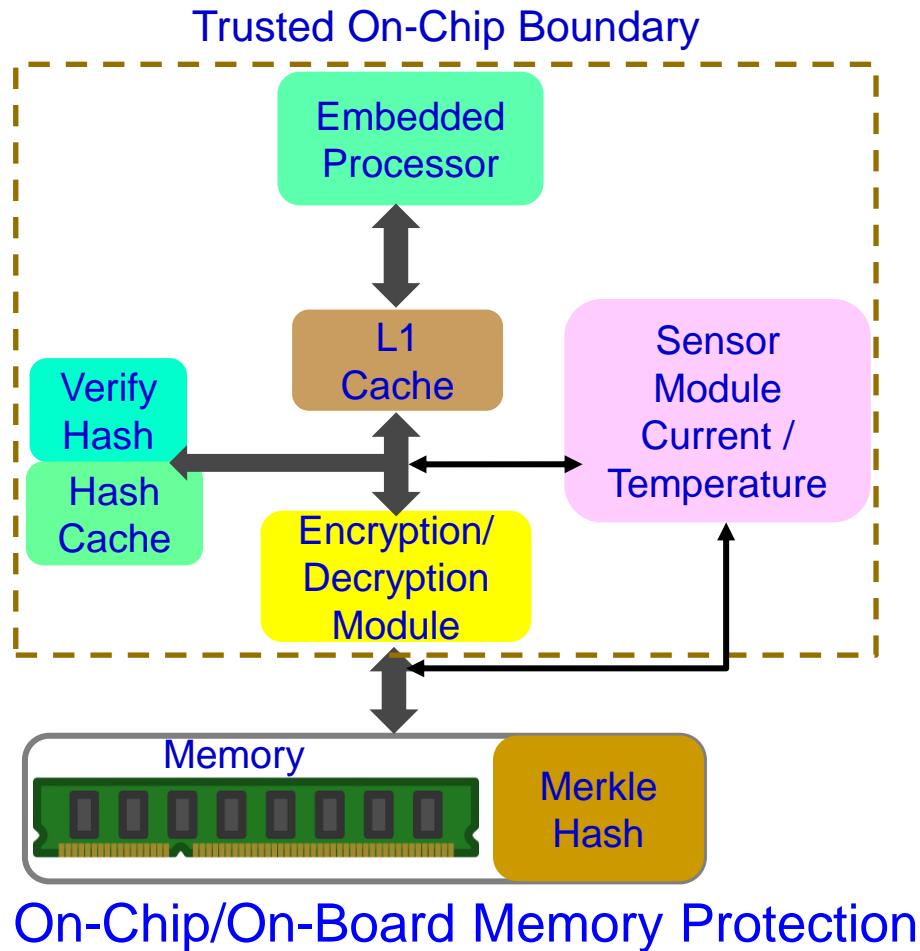

Memory integrity verification with 85% energy savings with minimal performance overhead.

Source: S. Nimgaonkar, M. Gomathisankaran, and S. P. Mohanty, "MEM-DnP: A Novel Energy Efficient Approach for Memory Integrity Detection and Protection in Embedded Systems", *Springer Circuits, Systems, and Signal Processing Journal (CSSP)*, Volume 32, Issue 6, December 2013, pp. 2581--2604.

Smart Healthcare Cybersecurity

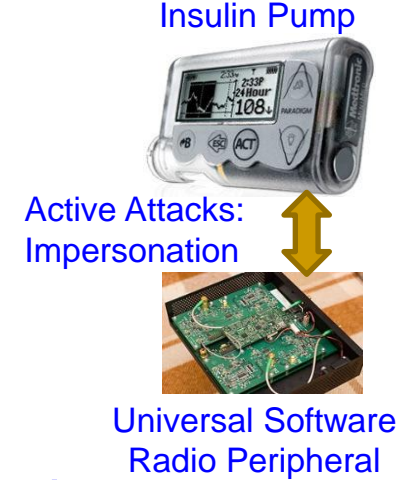
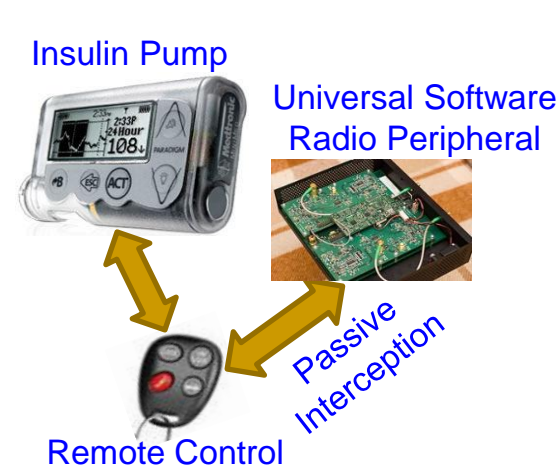
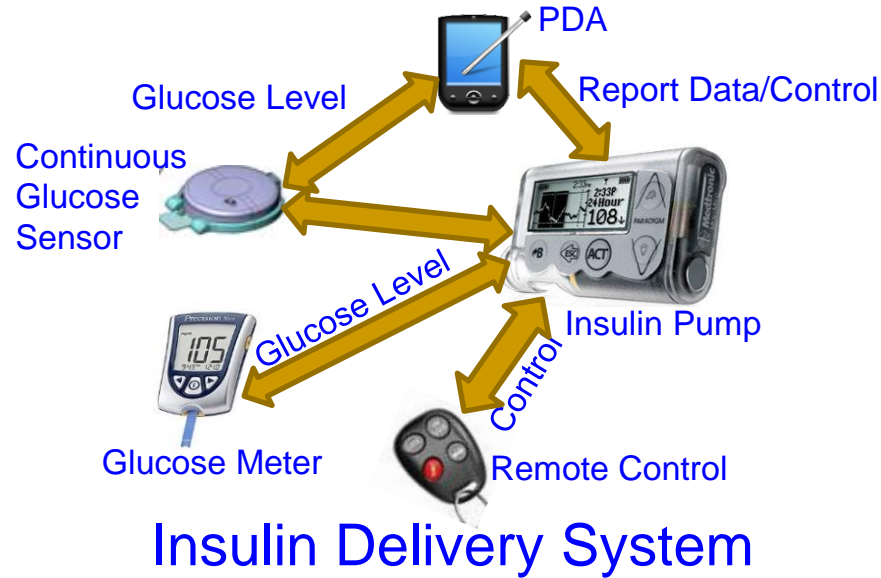

Security Attacks

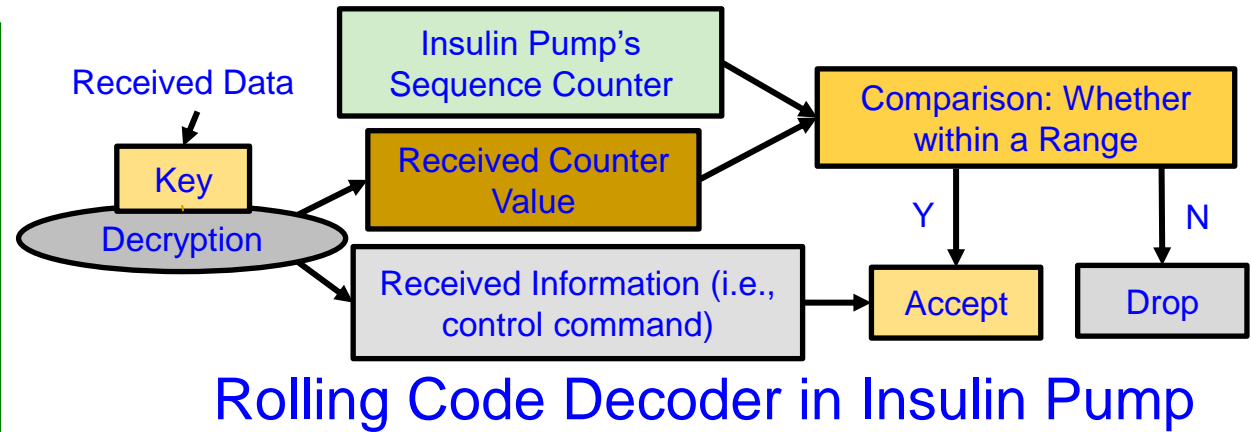
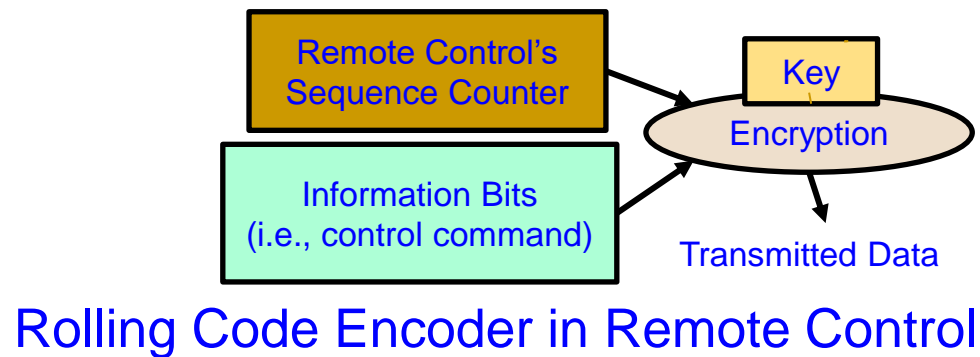

Source: Li and Jha 2011: HEALTH 2011

Blockchain in Smart Healthcare

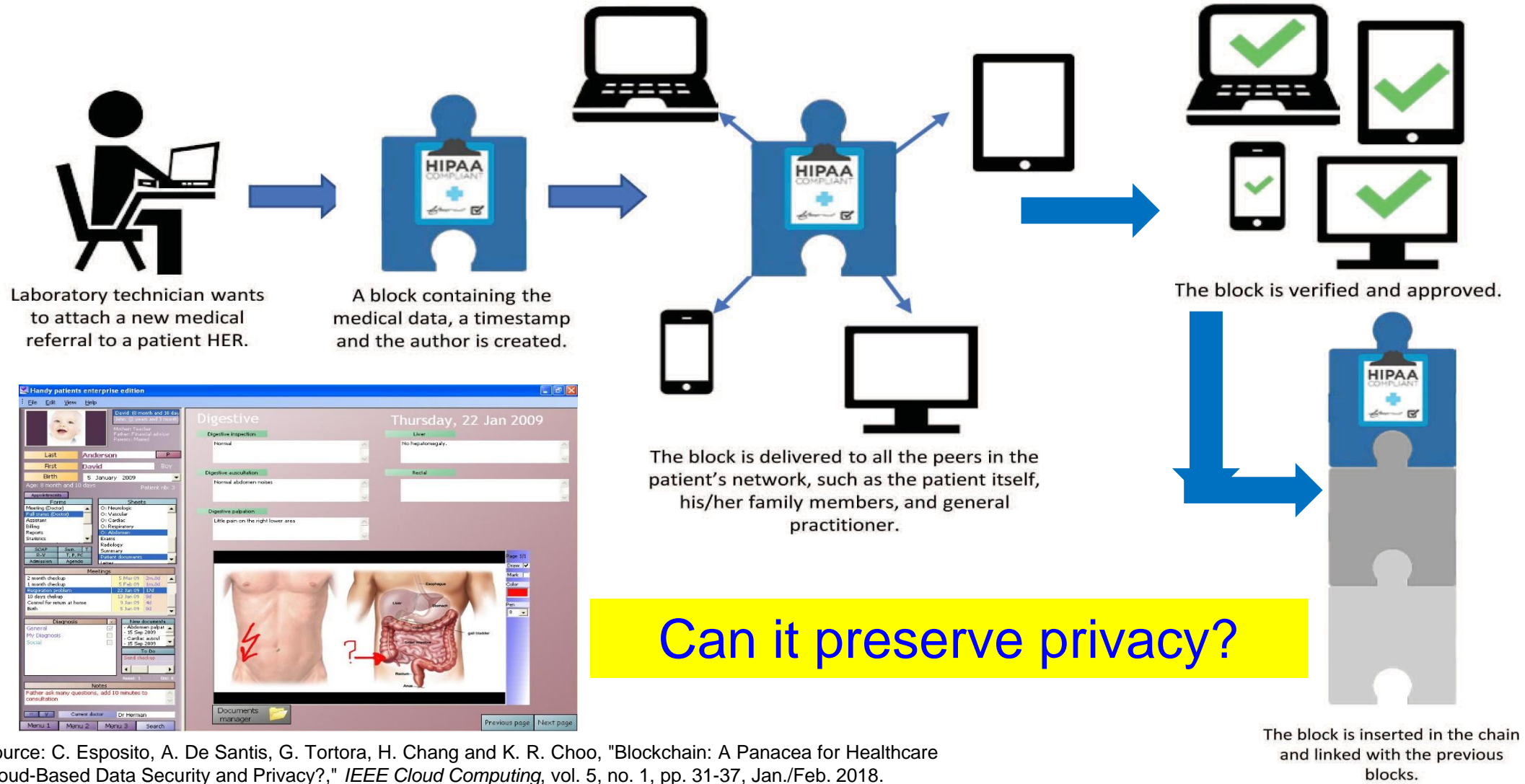

Autonomous Car Cybersecurity – Collision Avoidance

- ❑ **Attack:** Feeding of malicious sensor measurements to the control and the collision avoidance module. Such an attack on a position sensor can result in collisions between the vehicles.
- ❑ **Solutions:** “**Dynamic Watermarking**” of signals to detect and stop such attacks on cyber-physical systems.
- ❑ **Idea:** Superimpose each actuator i a random signal $e_i[t]$ (watermark) on control policy-specified input.

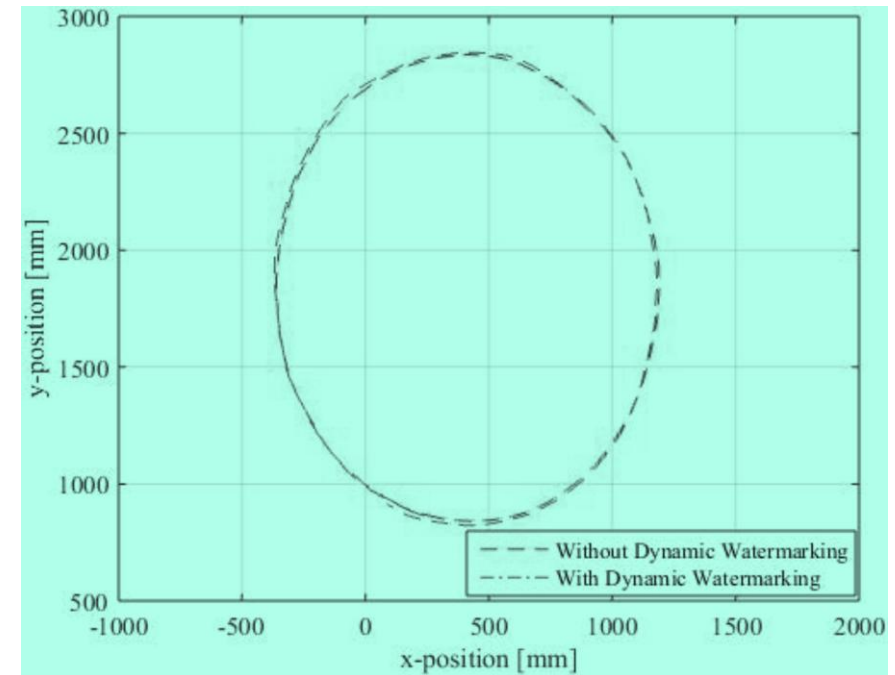

Source: Ko 2016, CPS-Sec 2016

Drawbacks of Existing Cybersecurity Solutions



IT Cybersecurity Solutions Can't be Directly Extended to IoT/CPS Cybersecurity

IT Cybersecurity

- IT infrastructure may be well protected rooms
- Limited variety of IT network devices
- Millions of IT devices
- Significant computational power to run heavy-duty security solutions
- IT security breach can be costly

IoT Cybersecurity

- IoT may be deployed in open hostile environments
- Significantly large variety of IoT devices
- Billions of IoT devices
- May not have computational power to run security solutions
- IoT security breach (e.g. in a IoMT device like pacemaker, insulin pump) can be life threatening

Incorporation of **Cybersecurity** of Electronic Systems, IoT, CPS, needs **Energy**, and hence affects **Performance**.

H-CPS Cybersecurity Measures is Hard - Energy Constrained

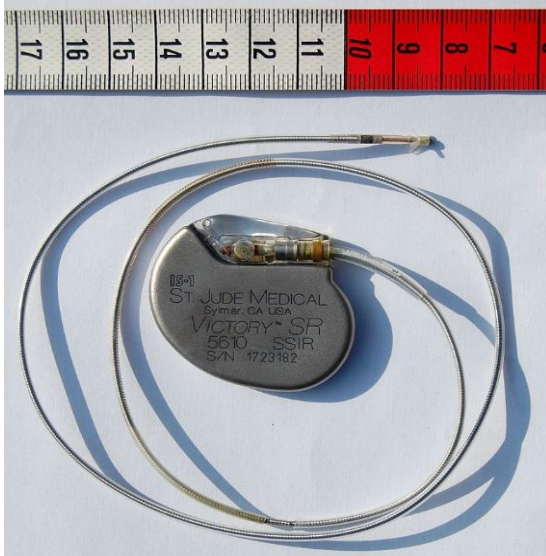

Pacemaker
Battery Life
- 10 years



Neurostimulator
Battery Life
- 8 years

- Implantable Medical Devices (IMDs) have integrated battery to provide energy to all their functions → Limited Battery Life depending on functions
- Higher battery/energy usage → Lower IMD lifetime
- Battery/IMD replacement → Needs surgical risky procedures

Source: C. Camara, P. Peris-Lopez, and J. E.Tapiadora, "Security and privacy issues in implantable medical devices: A comprehensive survey", *Elsevier Journal of Biomedical Informatics*, Volume 55, June 2015, Pages 272-289.

Smart Car Cybersecurity - Latency Constrained

Protecting Communications

Particularly any Modems for In-vehicle Infotainment (IVI) or in On-board Diagnostics (OBD-II)

Over The Air (OTA) Management
From the Cloud to Each Car

Cars can have 100 Electronic Control Units (ECUs) and 100 million lines of code, each from different vendors – Massive cybersecurity issues.

Protecting Each Module

Sensors, Actuators, and Anything with an Microcontroller Unit (MCU)

Mitigating Advanced Threats
Analytics in the Car and in the Cloud

Source: http://www.symantec.com/content/en/us/enterprise/white_papers/public-building-security-into-cars-20150805.pdf

■ Connected cars require latency of ms to communicate and avoid impending crash:

- Faster connection
- Low latency
- Energy efficiency

Security Mechanism Affects:

- Latency
- Mileage
- Battery Life



Car Cybersecurity – Latency Constrained

UAV Cybersecurity - Energy & Latency Constrained

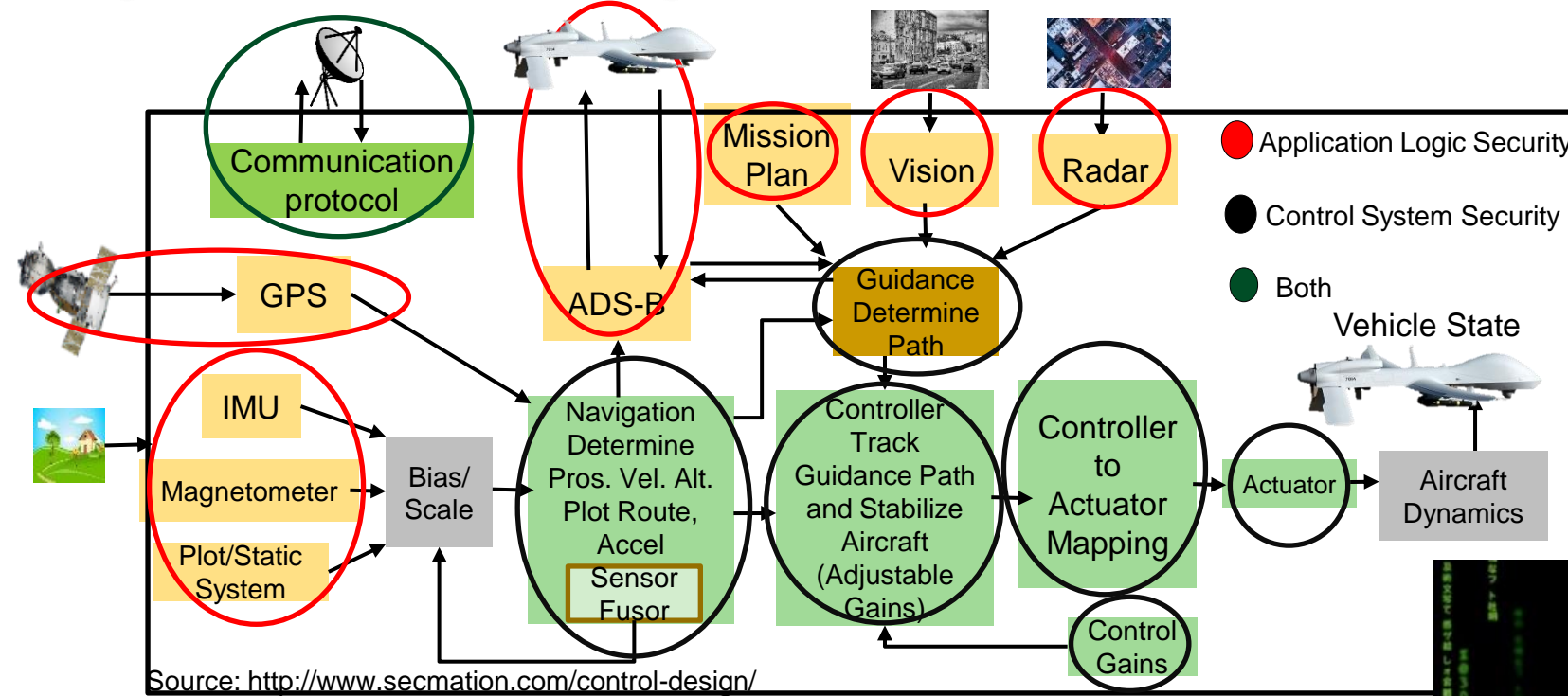

Cybersecurity Mechanisms Affect:
 Battery Life Latency Weight Aerodynamics

UAV Security – Energy and Latency Constraints



Source: <http://politicalblindspot.com/u-s-drone-hacked-and-hijacked-with-ease/>

Smart Grid Security Constraints

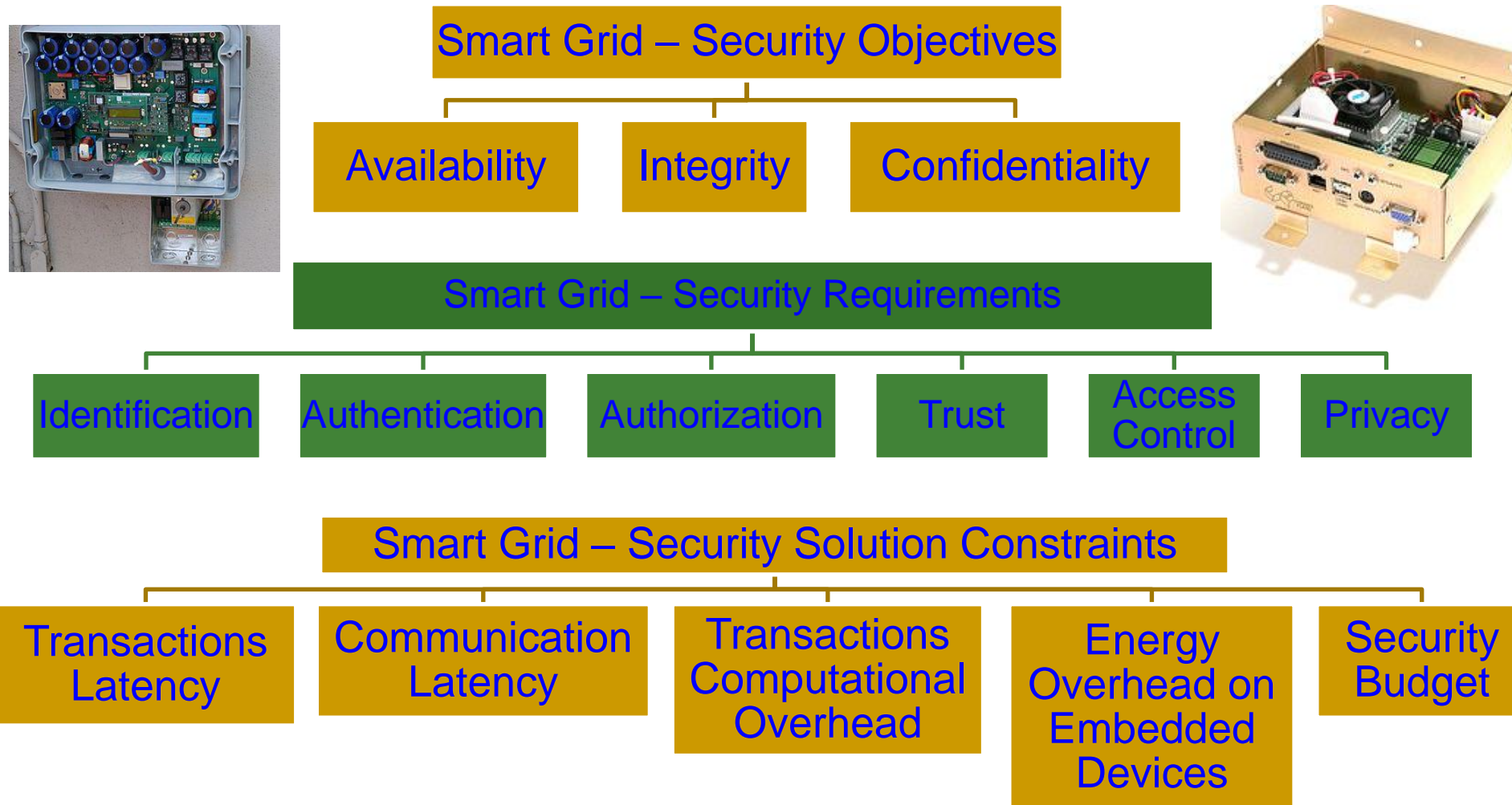

Source: R. K. Pandey and M. Misra, "Cyber security threats - Smart grid infrastructure," in *Proc. National Power Systems Conference (NPSC)*, 2016, pp. 1-6.

Cybersecurity Attacks – Software Vs Hardware Based

Software Based

- Software attacks via communication channels
- Typically from remote
- More frequent
- Selected **Software** based:
 - ❑ Denial-of-Service (DoS)
 - ❑ Routing Attacks
 - ❑ Malicious Injection
 - ❑ Injection of fraudulent packets
 - ❑ Snooping attack of memory
 - ❑ Spoofing attack of memory and IP address
 - ❑ Password-based attacks



Hardware Based

- Hardware or physical attacks
- Maybe local
- More difficult to prevent
- Selected **Hardware** based:
 - ❑ Hardware backdoors (e.g. Trojan)
 - ❑ Inducing faults
 - ❑ Electronic system tampering/ jailbreaking
 - ❑ Eavesdropping for protected memory
 - ❑ Side channel attack
 - ❑ Hardware counterfeiting

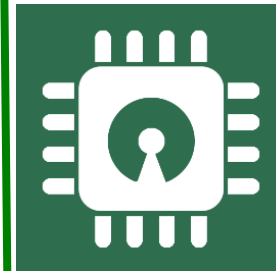

Source: Mohanty ICCE Panel 2018

Cybersecurity Solutions – Software Vs Hardware Based

Software Based



- Introduces latency in operation
- **Flexible** - Easy to use, upgrade and update
- Wider-Use - Use for all devices in an organization
- Higher recurring operational cost
- Tasks of encryption easy compared to hardware – substitution tables
- Needs general purpose processor to run
- Can't stop hardware reverse engineering

Source: Mohanty ICCE Panel 2018

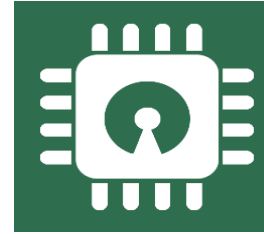

Hardware Based

- High-Speed operation
- Energy-Efficient operation
- Low-cost using ASIC and FPGA
- Tasks of encryption easy compared to software – bit permutation
- Easy **integration** in electronic systems
- Possible security at source-end like sensors, better suitable for IoT
- Susceptible to side-channel attacks
- Can't stop software reverse engineering

IoT/CPS Design – Multiple Objectives

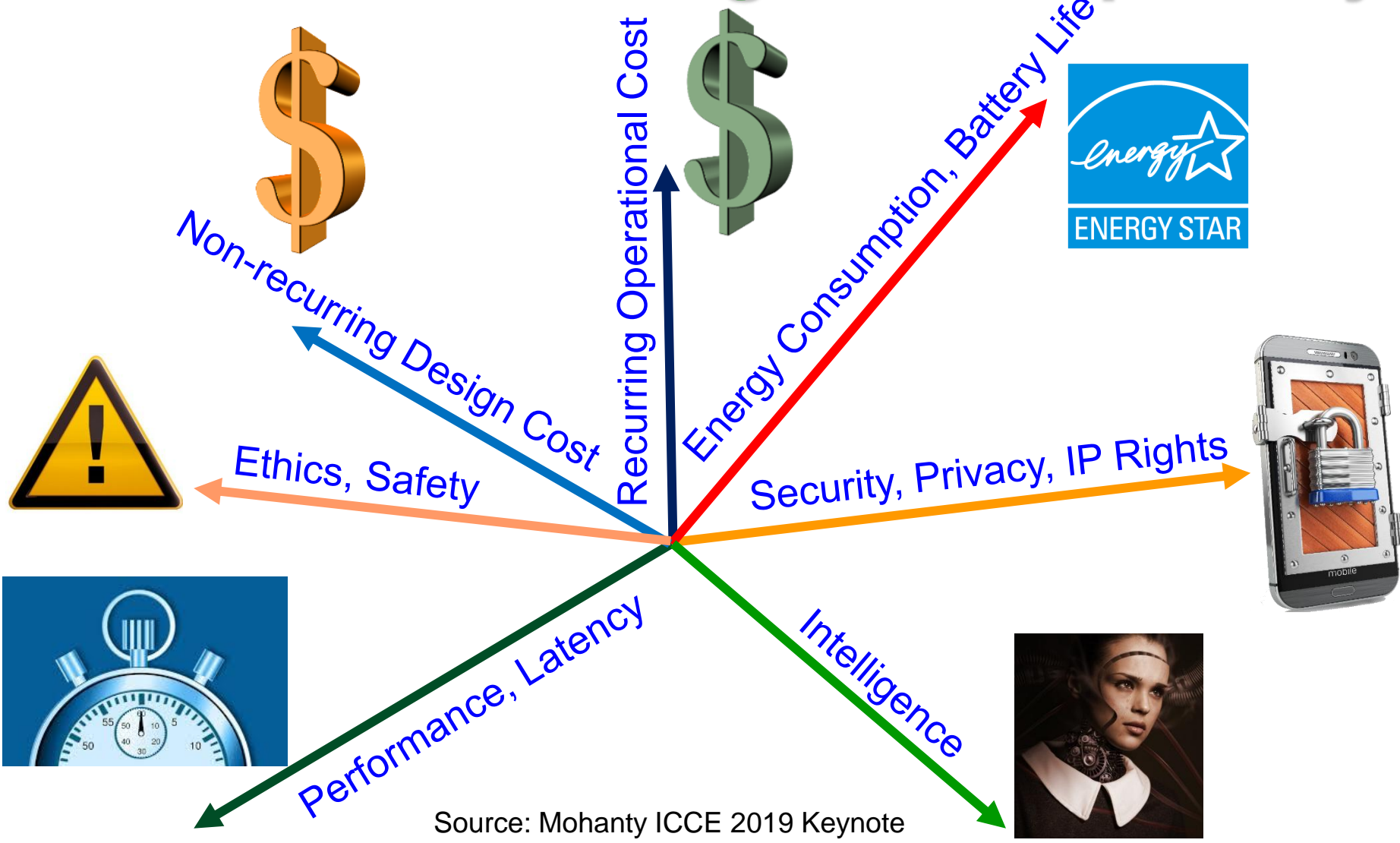

Smart Cities
Vs
Smart Villages

Source: Mohanty ICCE 2019 Keynote

Security by Design (SbD) and/or Privacy by Design (PbD)

Embedding of security/privacy into the architecture (hardware+software) of various products, programs, or services.

Retrofitting: Difficult → Impossible!



Source: <https://teachprivacy.com/tag/privacy-by-design/>

Security by Design (SbD)



7 Fundamental Principles

Proactive not Reactive

Security/Privacy as the Default

Security/Privacy Embedded into Design

Full Functionality - Positive-Sum, not Zero-Sum

End-to-End Security/Privacy - Lifecycle Protection

Visibility and Transparency

Respect for Users

Source: https://iapp.org/media/pdf/resource_center/Privacy%20by%20Design%20-%207%20Foundational%20Principles.pdf

SbD Principle – IoT/CPS Design Flow ...

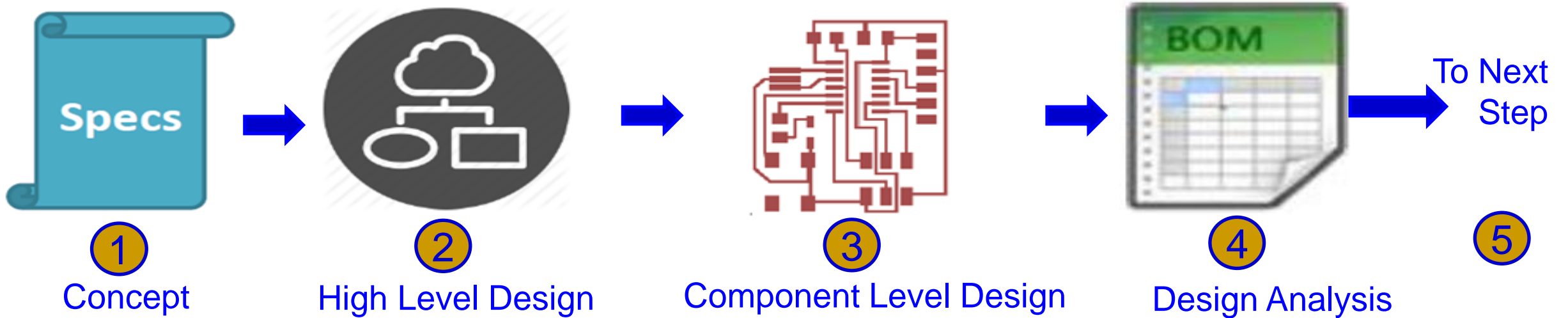

How to integrate cybersecurity and privacy at every stage of design flow?

Source: <http://events.linuxfoundation.org/sites/events/files/slides/Design%20-%20End-to-End%20%20IoT%20Solution%20-%20Shivakumar%20Mathapathi.pdf>

SbD Principle – IoT/CPS Design Flow ...

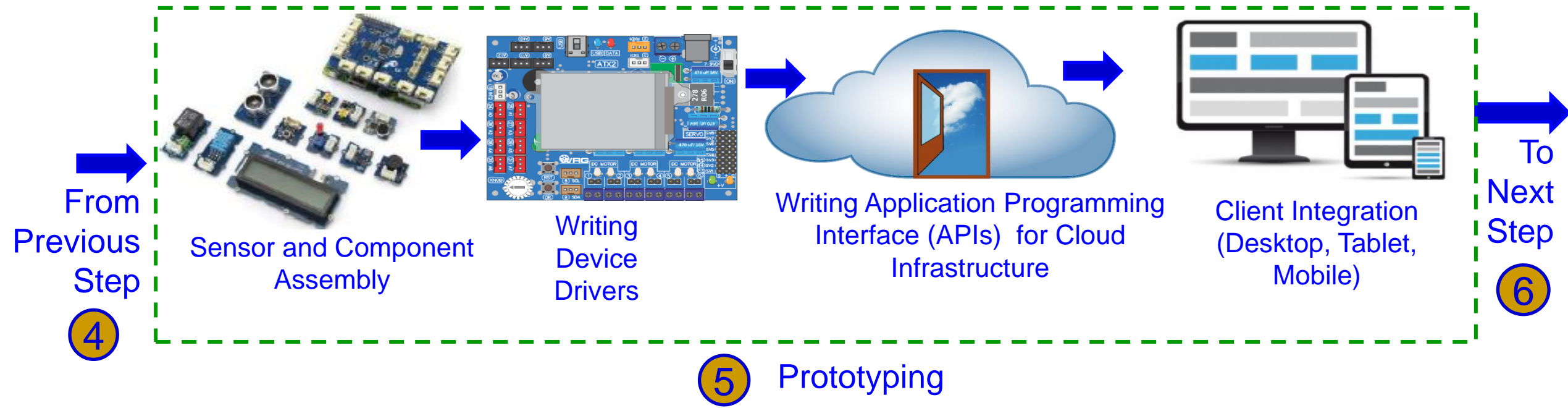

How to integrate cybersecurity and privacy at every stage of design flow?

Source: <http://events.linuxfoundation.org/sites/events/files/slides/Design%20-%20End-to-End%20%20IoT%20Solution%20-%20Shivakumar%20Mathapathi.pdf>

SbD Principle – IoT/CPS Design Flow



How to validate and document cybersecurity and privacy features at every stage of production?

Source: <http://events.linuxfoundation.org/sites/events/files/slides/Design%20-%20End-to-End%20IoT%20Solution%20-%20Shivakumar%20Mathapathi.pdf>

A Specific SbD Approach: Hardware-Assisted Security (HAS)

- **Hardware-Assisted Security:** Security provided by hardware for:

(1) information being processed,

Privacy by Design (PbD)

(2) hardware itself,

Security/Secure by Design (SbD)

(3) overall system

- Additional hardware components used for cybersecurity.

- Hardware design modification is performed.

- System design modification is performed.

RF Hardware Security

Digital Hardware Security – Side Channel

Hardware Trojan Protection

Information Security, Privacy, Protection

Bluetooth Hardware Security

Memory Protection

Digital Core IP Protection

Source: Mohanty ICCE 2018 Panel

Source: E. Kougianos, S. P. Mohanty, and R. N. Mahapatra, "Hardware Assisted Watermarking for Multimedia", Special Issue on Circuits and Systems for Real-Time Security and Copyright Protection of Multimedia, Elsevier International Journal on Computers and Electrical Engineering, Vol 35, No. 2, Mar 2009, pp. 339-358..

SbD/HAS - Advantages

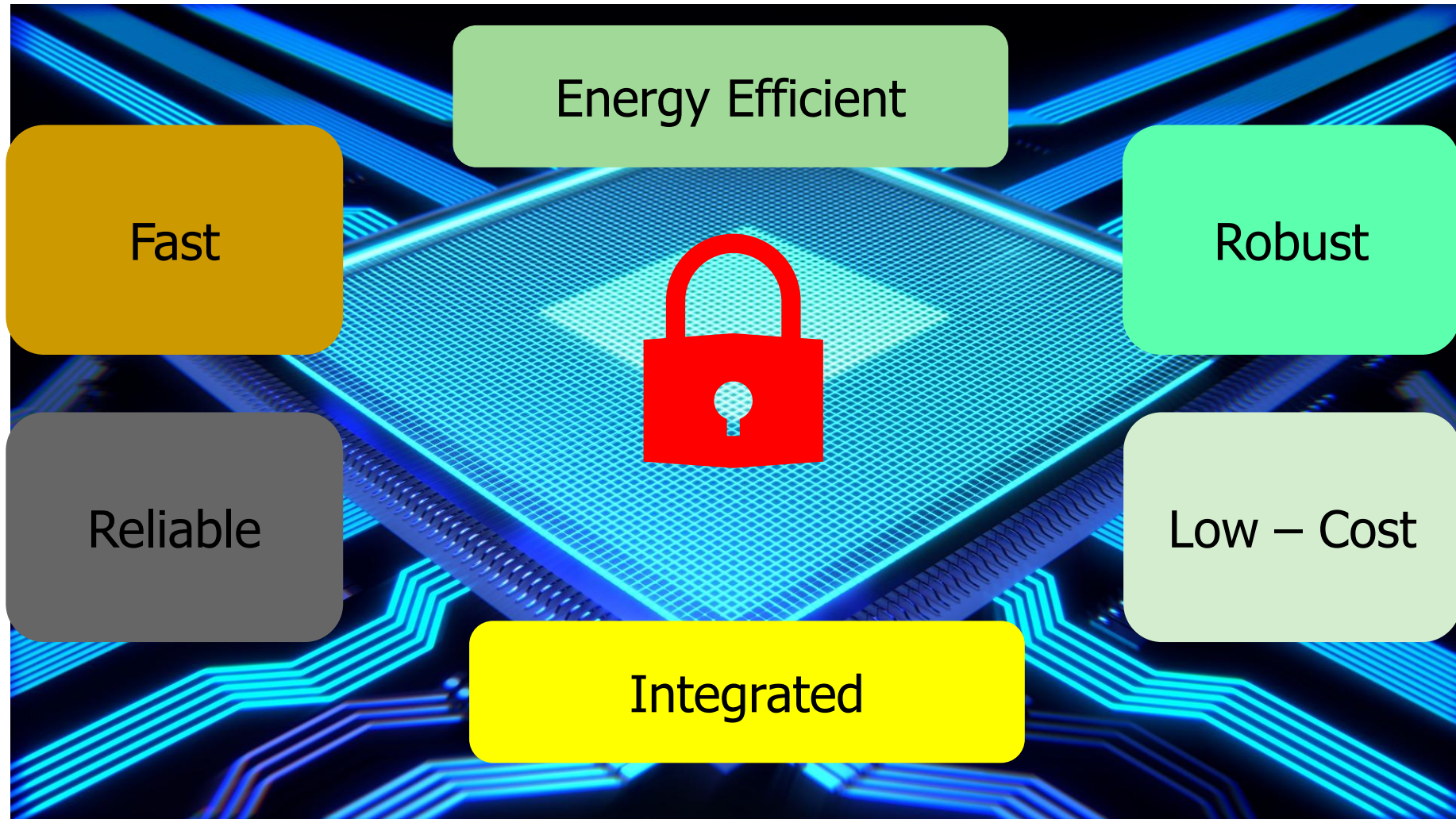

SbD/HAS Primitives – TPM, HSM, TrustZone, and PUF



Hardware Security Module (HSM)

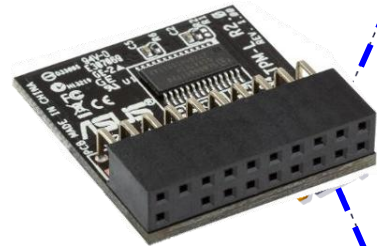

Trusted Platform Module (TPM)

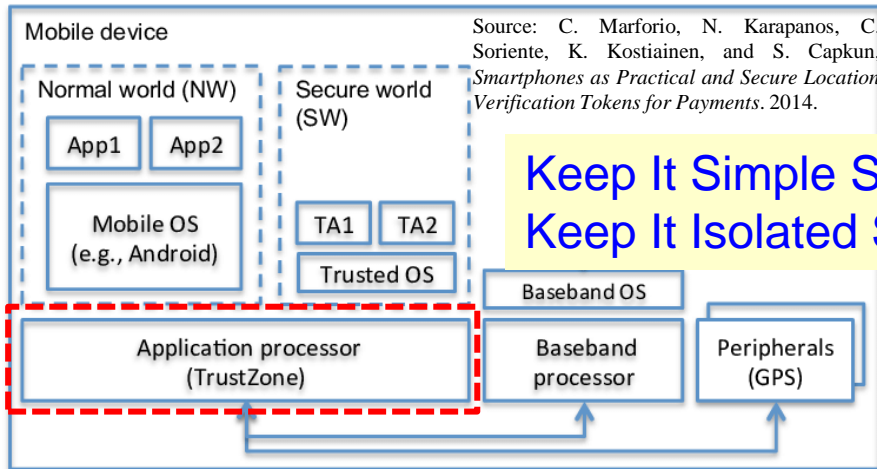
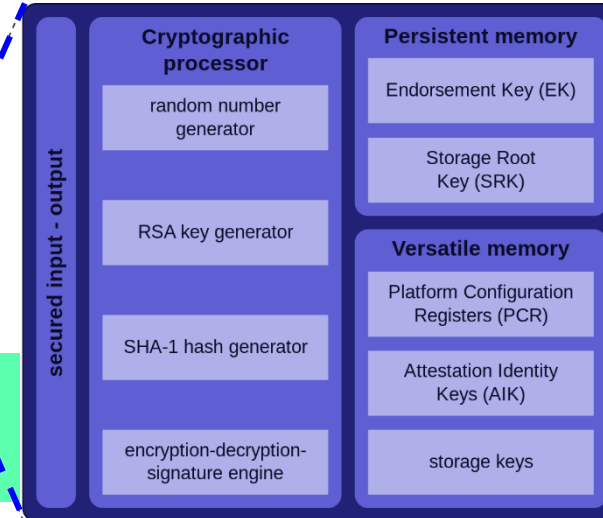

Keep It Simple Stupid (KISS) →
Keep It Isolated Stupid (KIIS)



Physical Unclonable Functions (PUF)

Source: Electric Power Research Institute (EPRI)

PMsec: Our Secure by Design Approach for Robust Security in Healthcare CPS

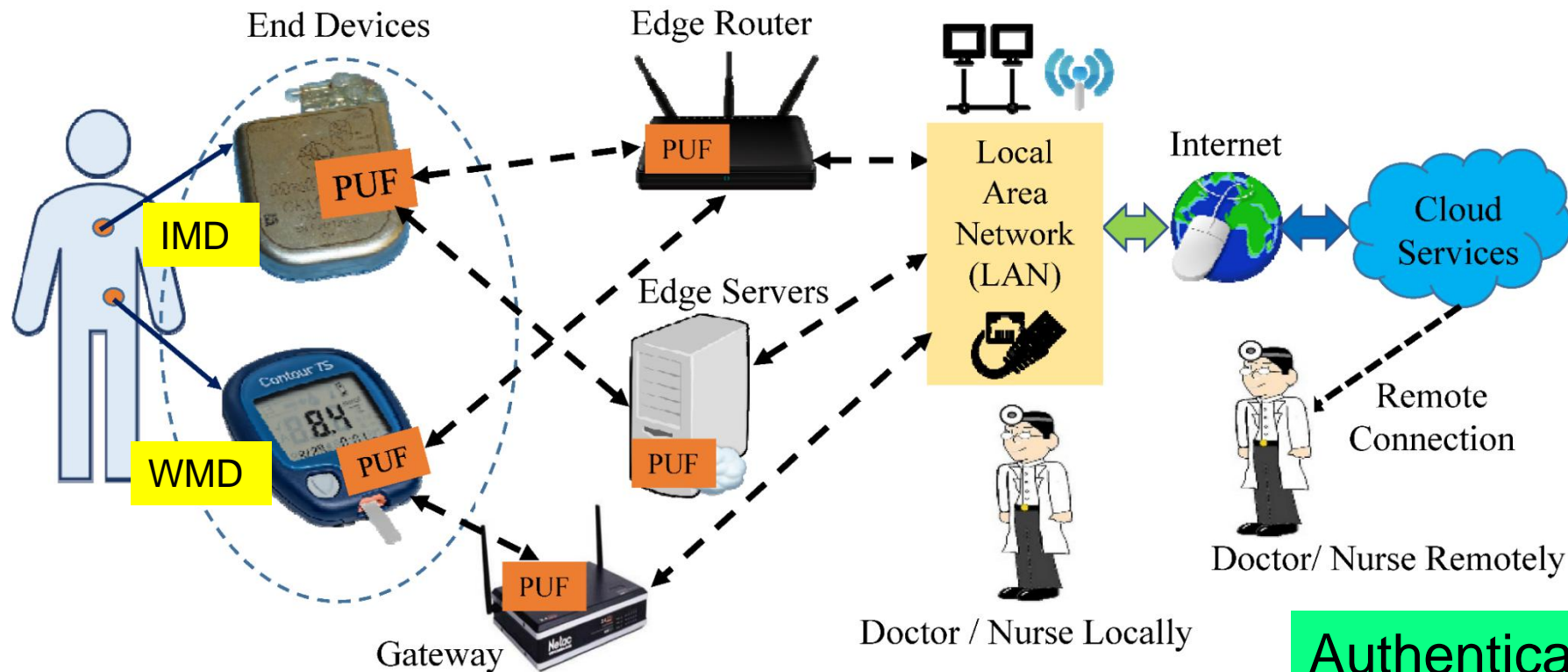

Authenticates Time - 1 sec
Power Consumption - 200 μ W

Source: V. P. Yanambaka, S. P. Mohanty, E. Kougianos, and D. Puthal, "PMsec: Physical Unclonable Function-Based Robust and Lightweight Authentication in the Internet of Medical Things", *IEEE Transactions on Consumer Electronics (TCE)*, Volume 65, Issue 3, August 2019, pp. 388--397.

iGLU: Accurate Glucose Level Monitoring and Secure Insulin Delivery

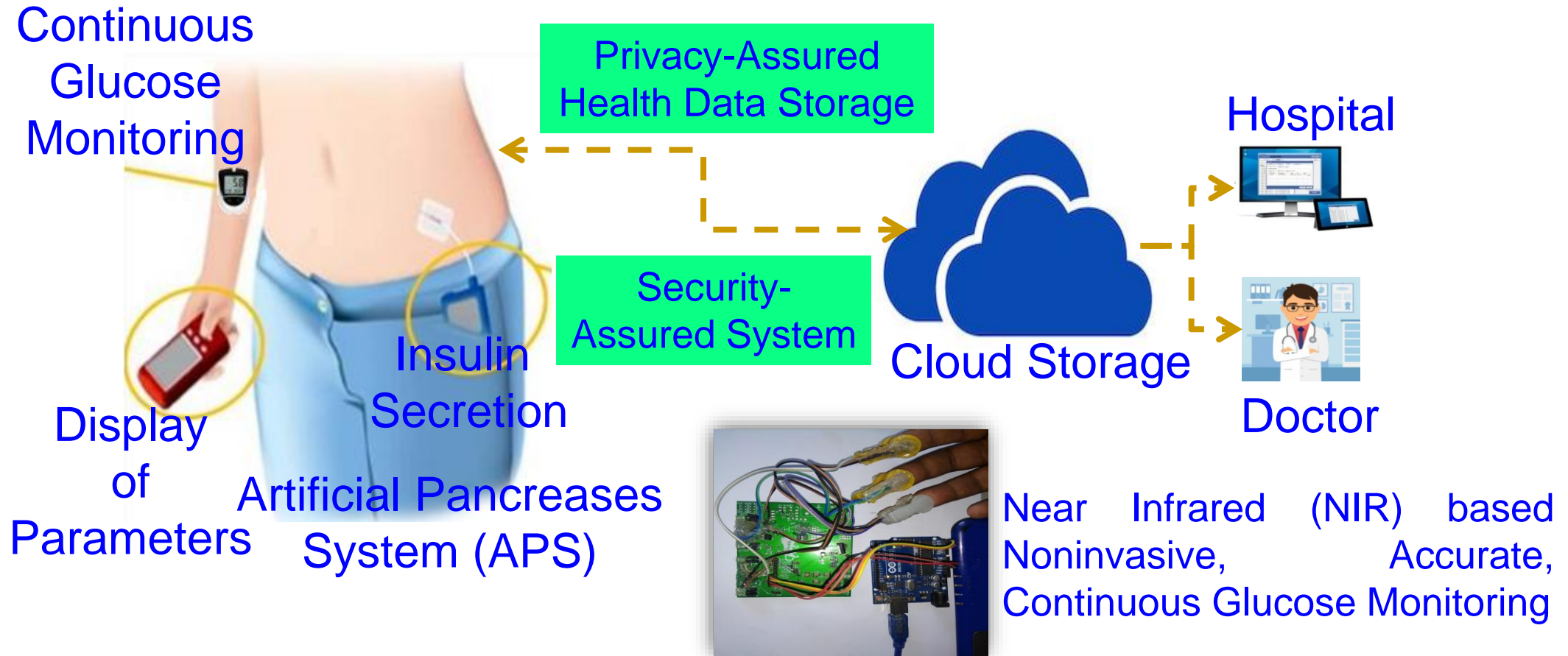

P. Jain, A. M. Joshi, and S. P. Mohanty, "iGLU: An Intelligent Device for Accurate Non-Invasive Blood Glucose-Level Monitoring in Smart Healthcare", *IEEE Consumer Electronics Magazine (MCE)*, Vol. 9, No. 1, January 2020, pp. 35–42.

We Proposed World's First Hardware-Integrated Blockchain (PUFchain) that is Scalable, Energy-Efficient, and Fast

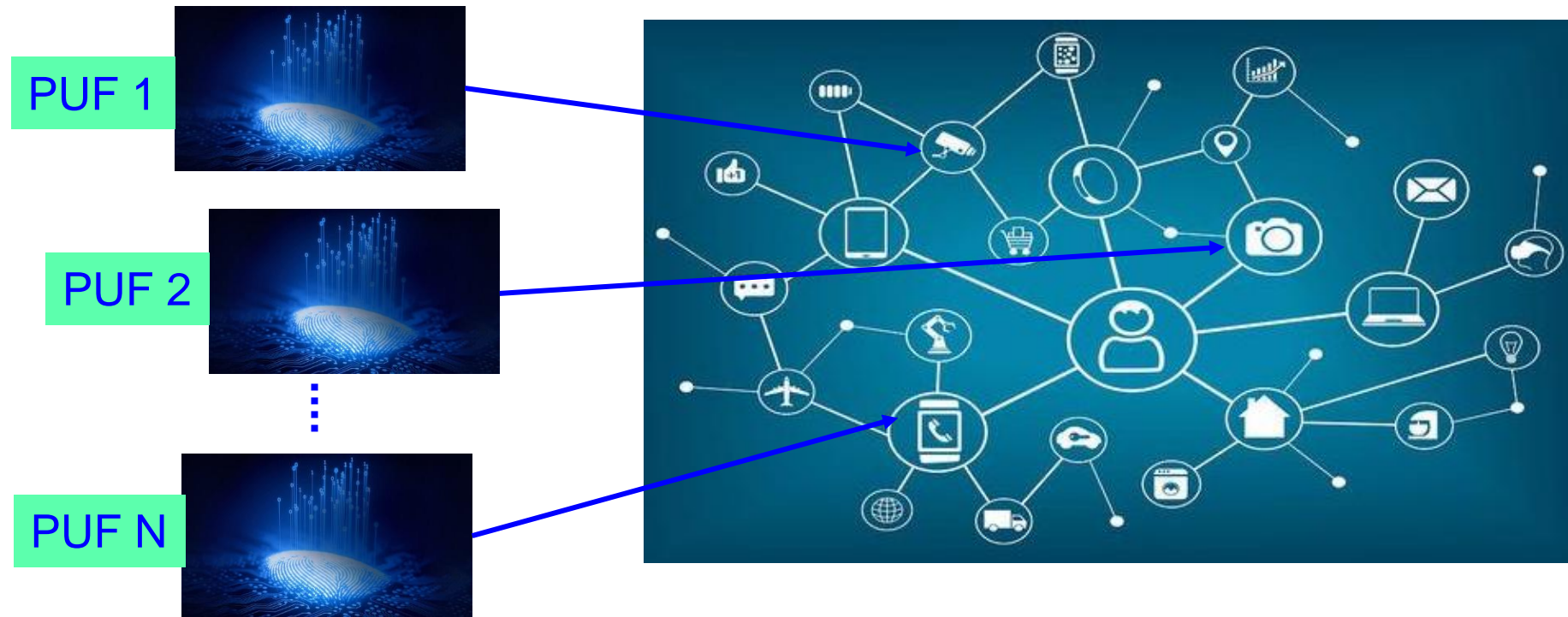

Source: S. P. Mohanty, V. P. Yanambaka, E. Kougianos, and D. Puthal, "PUFchain: Hardware-Assisted Blockchain for Sustainable Simultaneous Device and Data Security in Internet of Everything (IoE)", *IEEE Consumer Electronics Magazine (MCE)*, Vol. 9, No. 2, March 2020, pp. 8-16.

PUFchain: Our Hardware-Assisted Scalable Blockchain

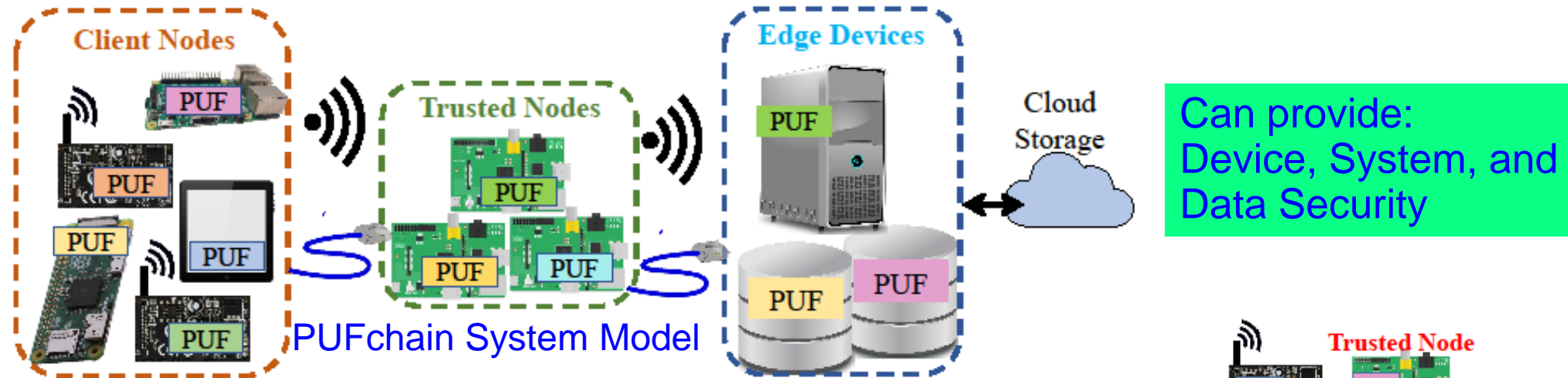

Can provide:
Device, System, and
Data Security

PUFChain 2 Modes:
(1) PUF Mode and
(2) PUFChain Mode

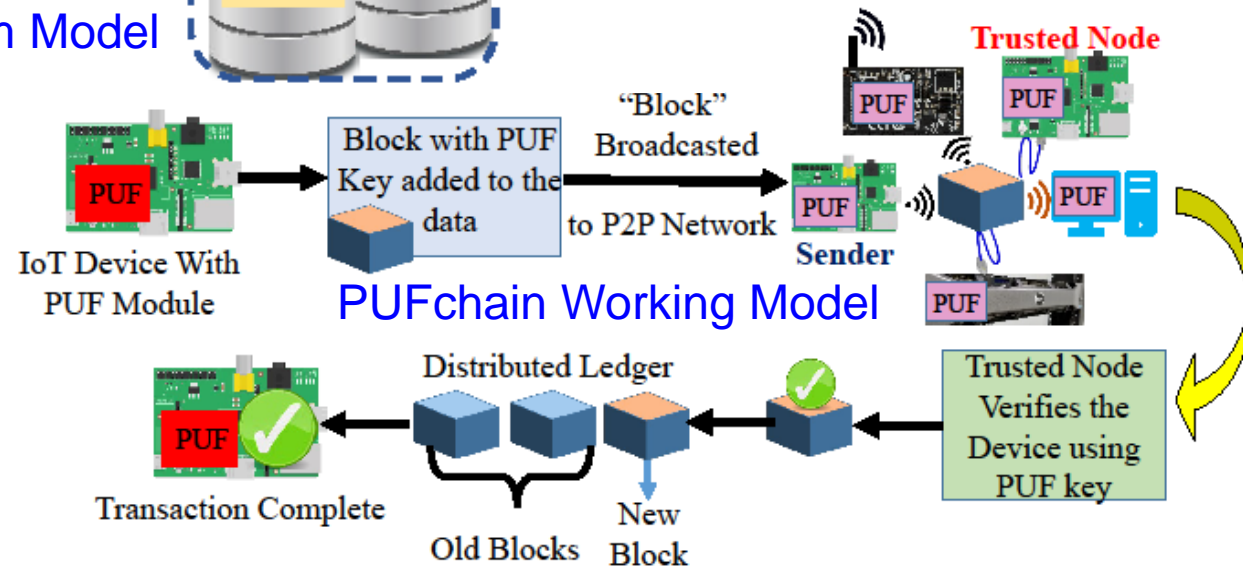

- ✓ PoP is 1,000X faster than PoW
- ✓ PoP is 5X faster than PoAh

Source: S. P. Mohanty, V. P. Yanambaka, E. Kougianos, and D. Puthal, "PUFchain: Hardware-Assisted Blockchain for Sustainable Simultaneous Device and Data Security in Internet of Everything (IoE)", *IEEE Consumer Electronics Magazine (MCE)*, Vol. 9, No. 2, March 2020, pp. 8-16.

Smart Grid Cybersecurity

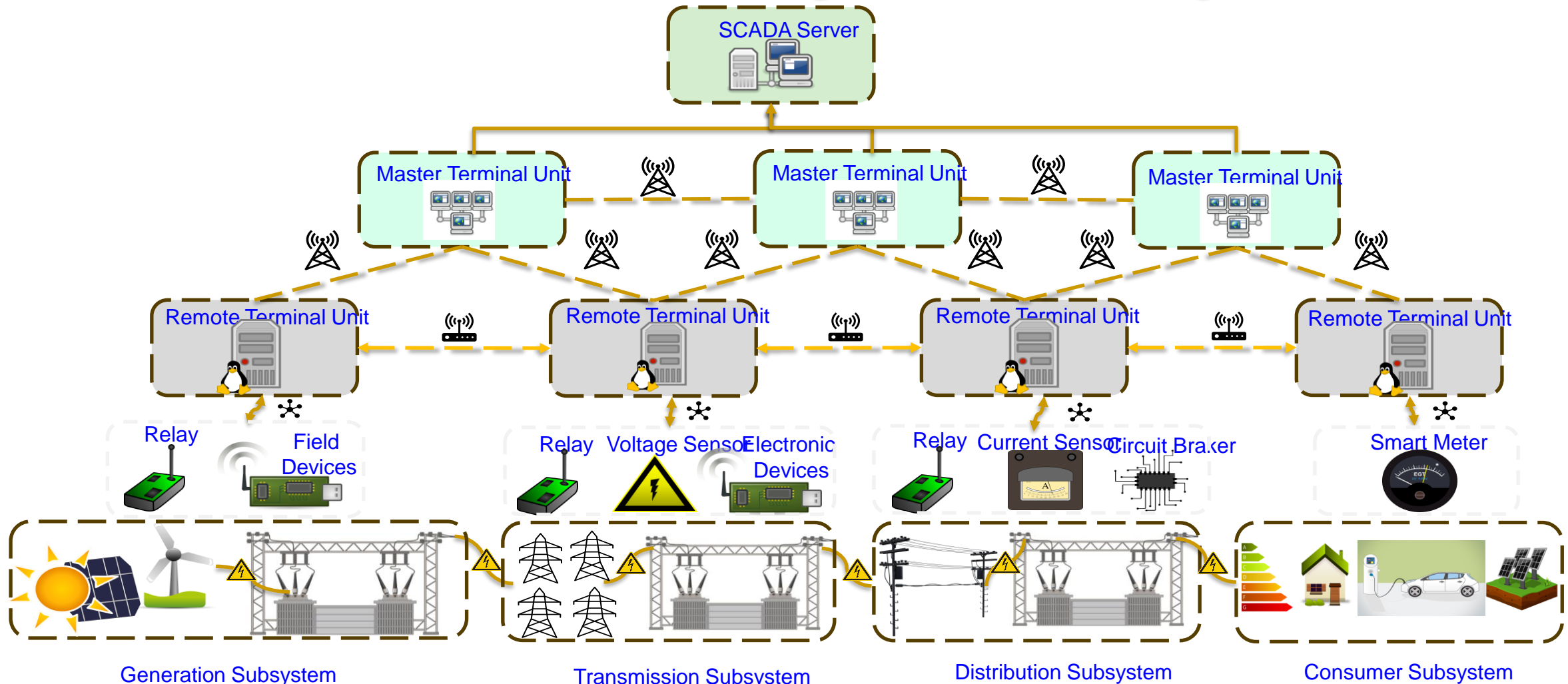

Source: V. K. V. V. Bathalapalli, **S. P. Mohanty**, C. Pan, and E. Kougianos, "QPUF 2.0: Exploring Quantum Physical Unclonable Functions for Security-by-Design of Energy Cyber-Physical Systems", *arXiv Quantum Physics*, [arXiv:2410.12702](https://arxiv.org/abs/2410.12702), Oct 2024, 26-pages.

⋯ Serial/Wireless
--- Wide Area Network
- - - Wireless Connection/LAN

Our QPUF: Quantum PUF for SbD of Industrial IoT

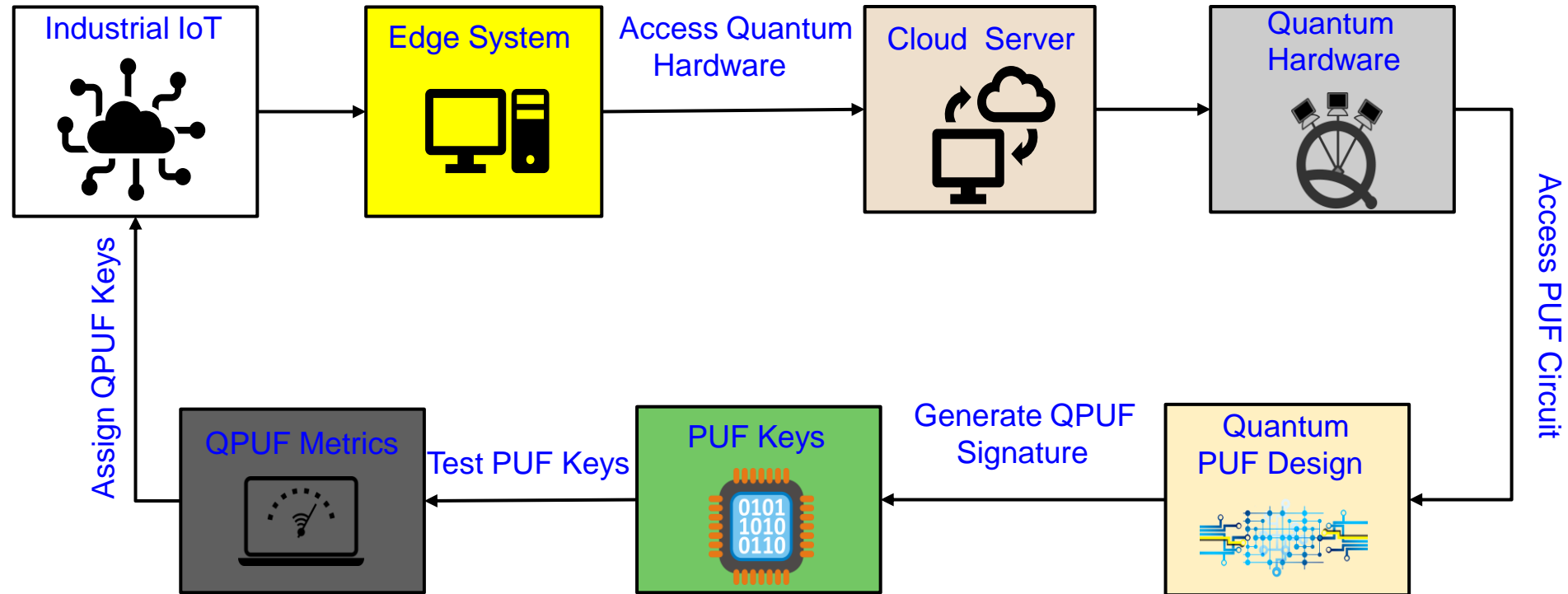

Source: V. K. V. V. Bathalapalli, **S. P. Mohanty**, C. Pan, and E. Kougianos, "QPUF: Quantum Physical Unclonable Functions for Security-by-Design of Industrial Internet-of-Things", in *Proceedings of the IEEE International Symposium on Smart Electronic Systems (iSES)*, 2023, pp. 296--301, DOI: <https://doi.org/10.1109/iSES58672.2023.00067>.

Our QPUF 2.0 ...

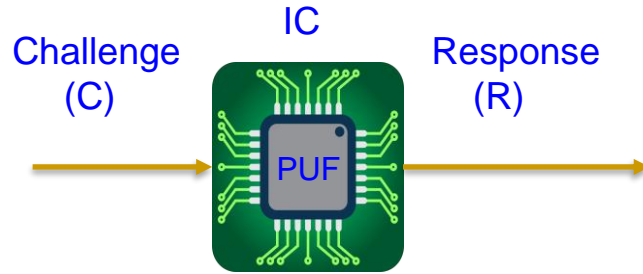

C	R
101101011	101001010
111001010	001101011
101001000	110110100
000101110	101110010

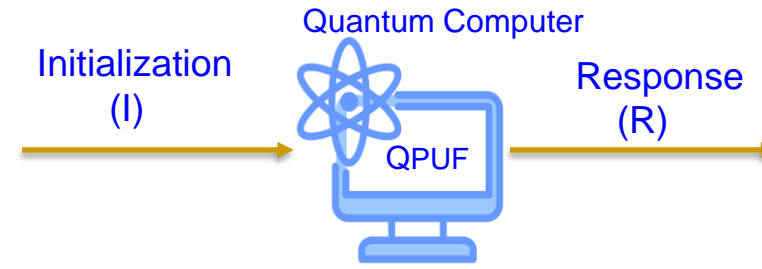

$I \rightarrow (\text{Angle, Quantum State } (0|1))$ $R \rightarrow 1010010$

$$\begin{array}{l}
 I_1 \rightarrow \left(\frac{\pi}{2}, 0\right) \\
 \left(\frac{\pi}{2}, 1\right) \\
 \left(\frac{\pi}{2}, 0\right) \\
 \left(\frac{\pi}{2}, 1\right) \\
 \rightarrow R_1
 \end{array}
 \quad
 \begin{array}{l}
 I_2 \rightarrow \left(\frac{\pi}{5}, 1\right) \\
 \left(\frac{\pi}{5}, 1\right) \\
 \left(\frac{\pi}{5}, 0\right) \\
 \left(\frac{\pi}{5}, 0\right) \\
 \rightarrow R_2
 \end{array}
 \quad
 \dots
 \quad
 \begin{array}{l}
 I_n \rightarrow \left(\frac{\pi}{4}, 1\right) \\
 \left(\frac{\pi}{4}, 0\right) \\
 \left(\frac{\pi}{4}, 1\right) \\
 \left(\frac{\pi}{4}, 0\right) \\
 \rightarrow R_n
 \end{array}$$

Source: V. K. V. V. Bathalapalli, **S. P. Mohanty**, C. Pan, and E. Kougianos, "QPUF 2.0: Exploring Quantum Physical Unclonable Functions for Security-by-Design of Energy Cyber-Physical Systems", *arXiv Quantum Physics*, [arXiv:2410.12702](https://arxiv.org/abs/2410.12702), Oct 2024, 26-pages.

Our SbD: Eternal-Thing: Combines Security and Energy Harvesting at the IoT-Edge

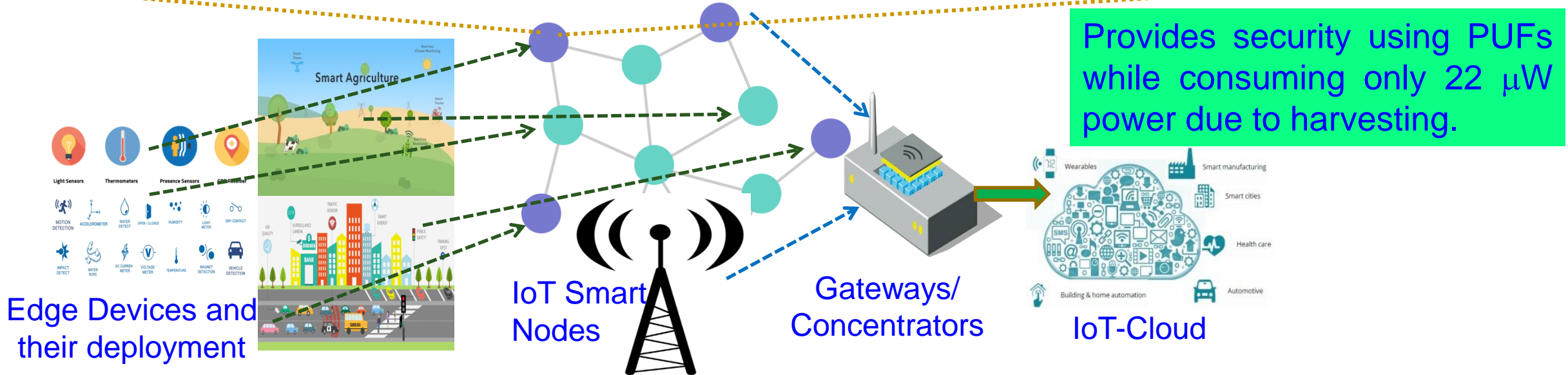

Source: S. K. Ram, S. R. Sahoo, Banee, B.Das, K. K. Mahapatra, and S. P. Mohanty, "Eternal-Thing: A Secure Aging-Aware Solar-Energy Harvester Thing for Sustainable IoT", *IEEE Transactions on Sustainable Computing*, Vol. 6, No. 2, April 2021, pp. 320—333, DOI: <https://doi.org/10.1109/TSUSC.2020.2987616>.

Collaborative Edge Computing is Cost Effective Sustainable Computing for Smart Villages

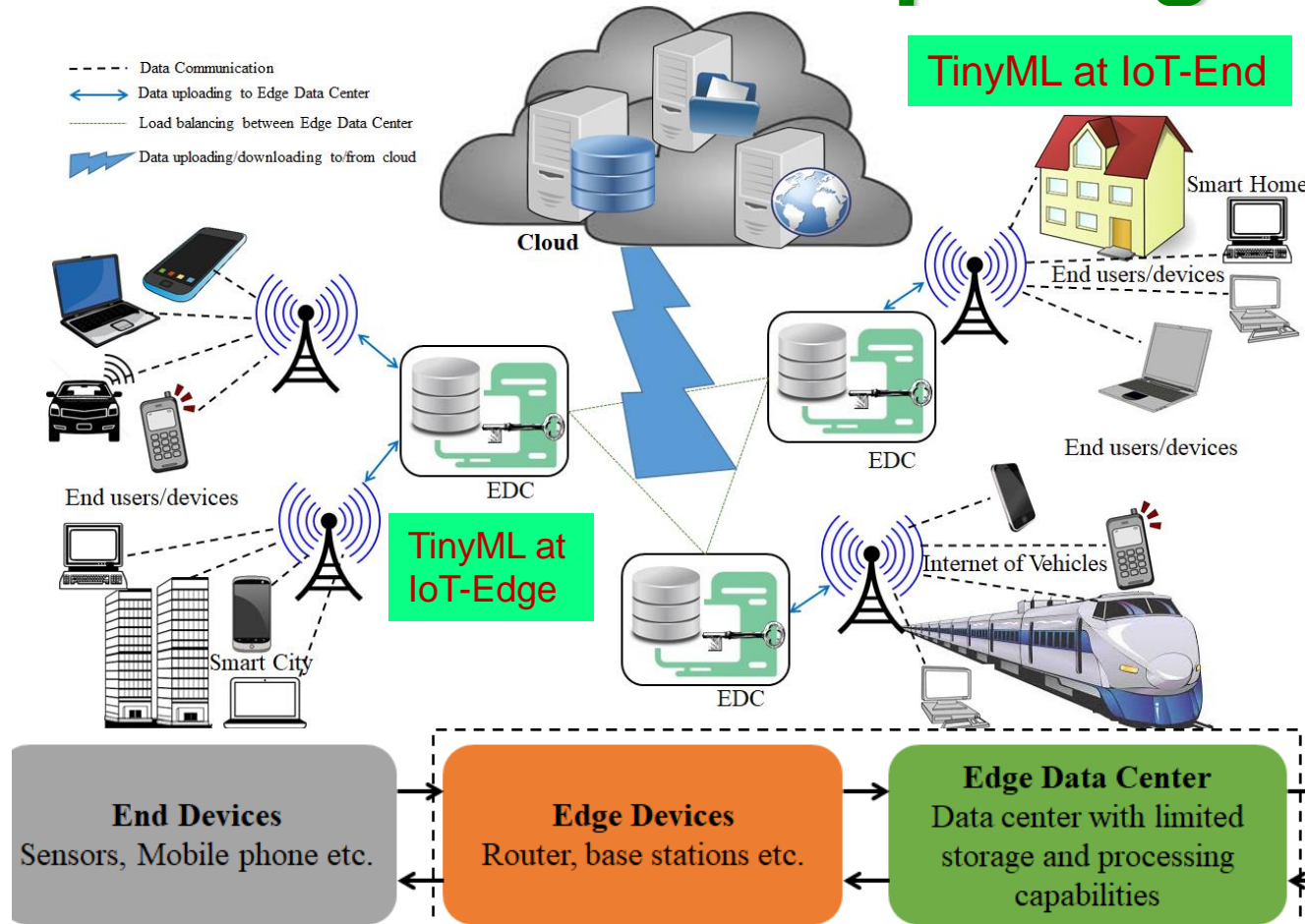

Collaborative edge computing connects the IoT-edges of multiple organizations that can be near or far from each other
 → Providing bigger computational capability at the edge with lower design and operation cost.

Source: D. Puthal, M. S. Obaidat, P. Nandā, M. Prasad, S. P. Mohanty, and A. Y. Zomāyā, "Secure and Sustainable Load Balancing of Edge Data Centers in Fog Computing", *IEEE Communications Mag*, Vol. 56, No 5, May 2018, pp. 60–65, DOI: <https://doi.org/10.1109/MCOM.2018.1700795>.

Our Fortified-Edge: PUF based Authentication in Collaborative Edge Computing

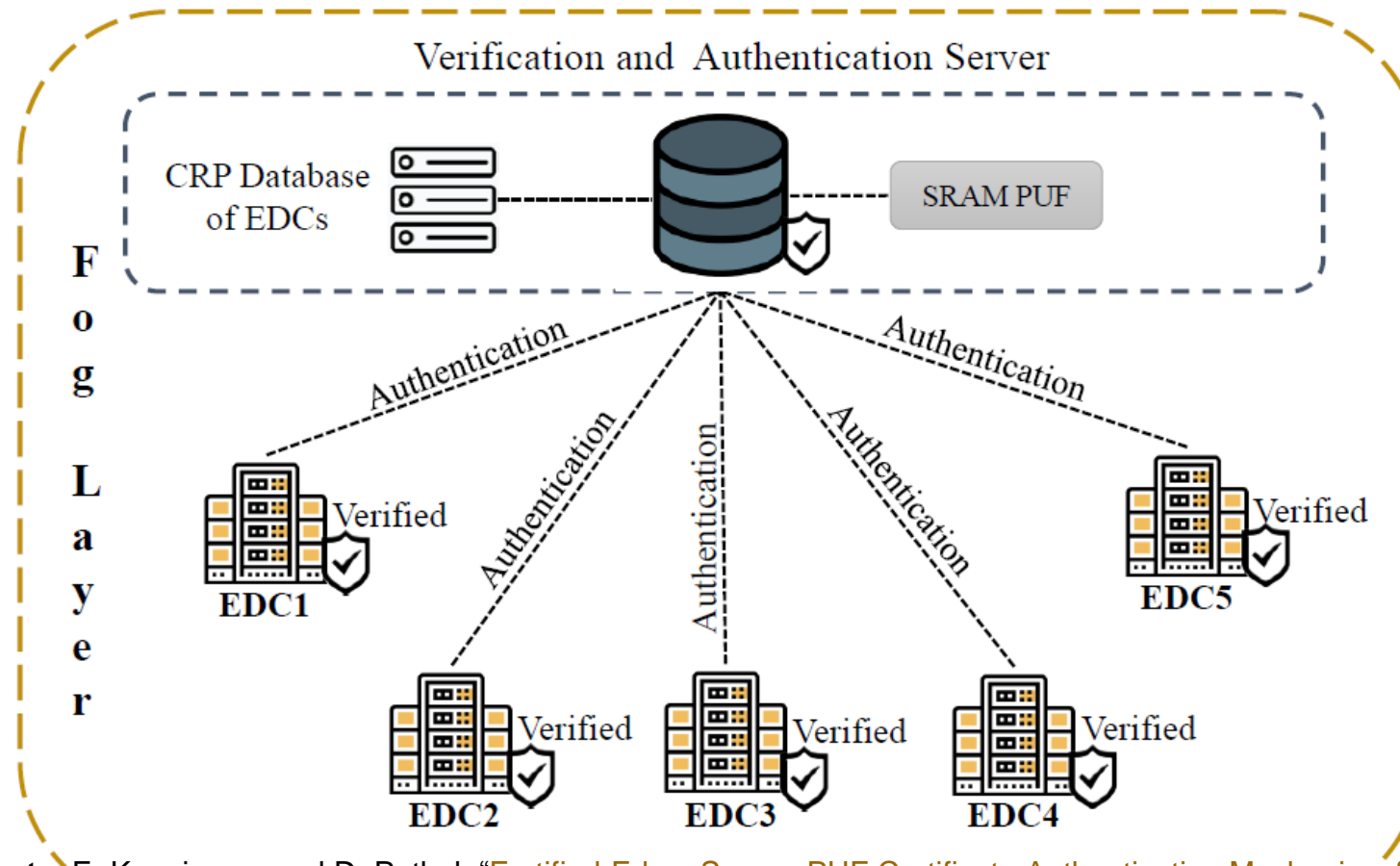

Source: S. G. Aarella, **S. P. Mohanty**, E. Kougianos, and D. Puthal, "Fortified-Edge: Secure PUF Certificate Authentication Mechanism for Edge Data Centers in Collaborative Edge Computing", in *Proceedings of the ACM Great Lakes Symposium on VLSI (GLSVLSI)*, 2023, pp. 249–254, DOI: <https://doi.org/10.1145/3583781.3590249>.

Data and System Authentication and Ownership Protection – My 20 Years of Experiences

Data

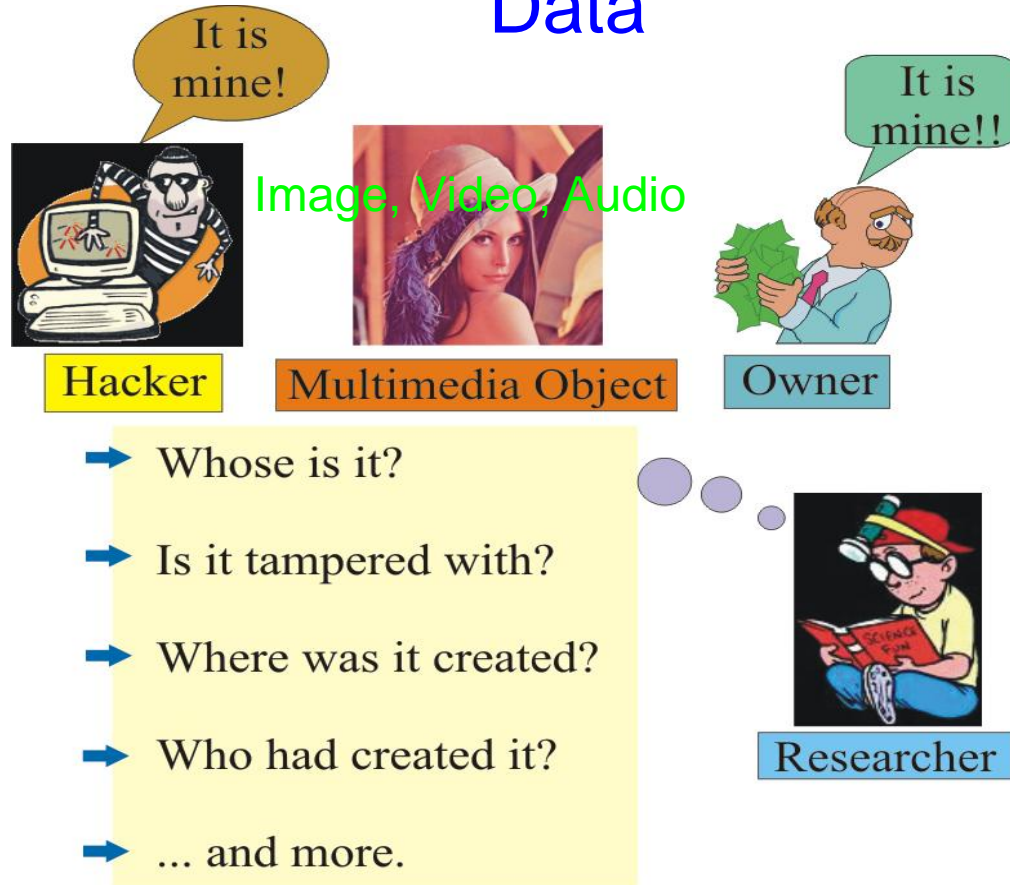

System

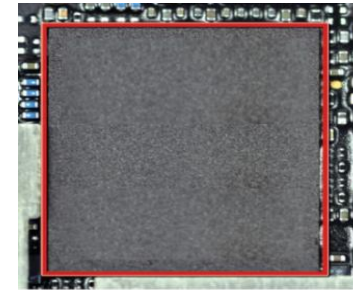

Chip at Original Design House

IP cores or reusable cores are used as a cost effective SoC solution but sharing poses a security and ownership issues.

Goes to Another Design House for Reuse

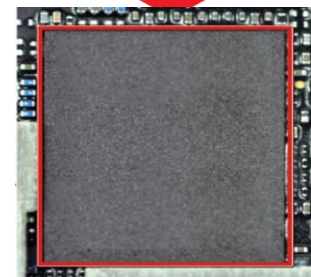

Chip at Another Design House

? Who Owns ?

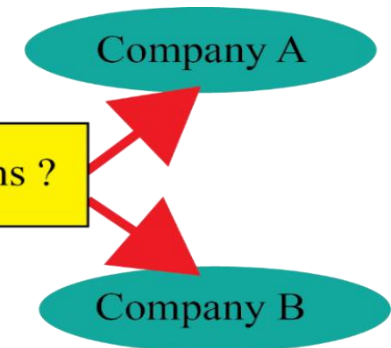

Source: S. P. Mohanty, A. Sengupta, P. Guturu, and E. Kougianos, "Everything You Want to Know About Watermarking", *IEEE Consumer Electronics Magazine (CEM)*, Volume 6, Issue 3, July 2017, pp. 83--91.

Secure Digital Camera (SDC) – My Invention

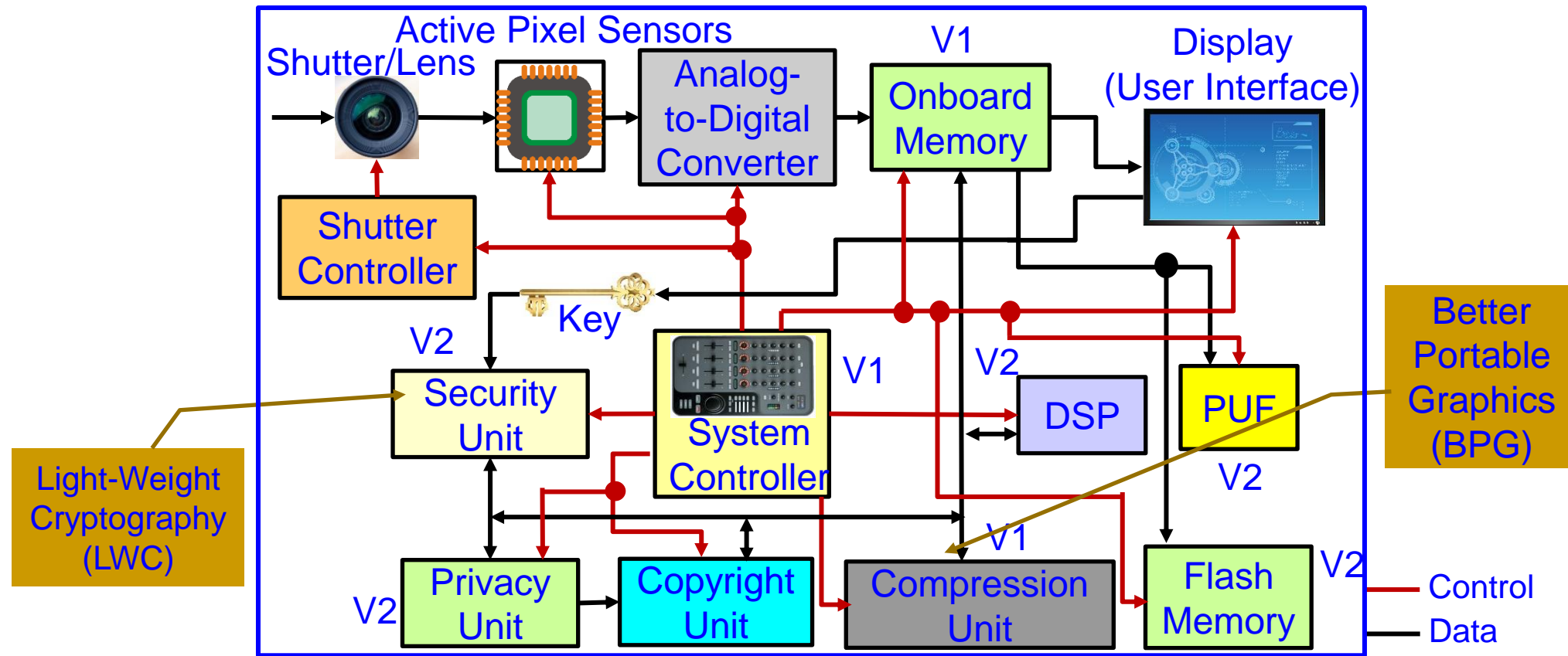

Include additional/alternative hardware/software components and uses DVFS like technology for energy and performance optimization.

Security and/or Privacy by Design (SbD and/or PbD)

Source: S. P. Mohanty, "A Secure Digital Camera Architecture for Integrated Real-Time Digital Rights Management", *Elsevier Journal of Systems Architecture (JSA)*, Volume 55, Issues 10-12, October-December 2009, pp. 468-480.

Our Design: First Ever Watermarking Chip for Source-End Visual Data Protection

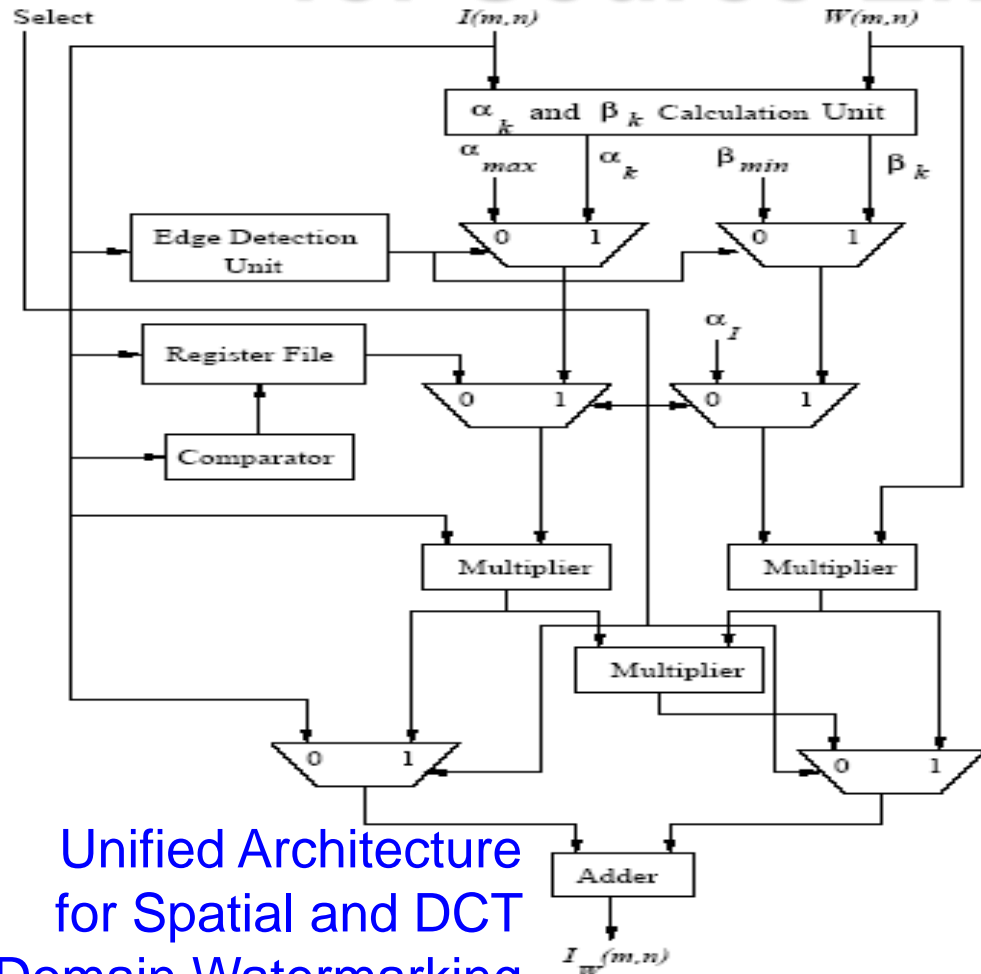

Unified Architecture for Spatial and DCT Domain Watermarking

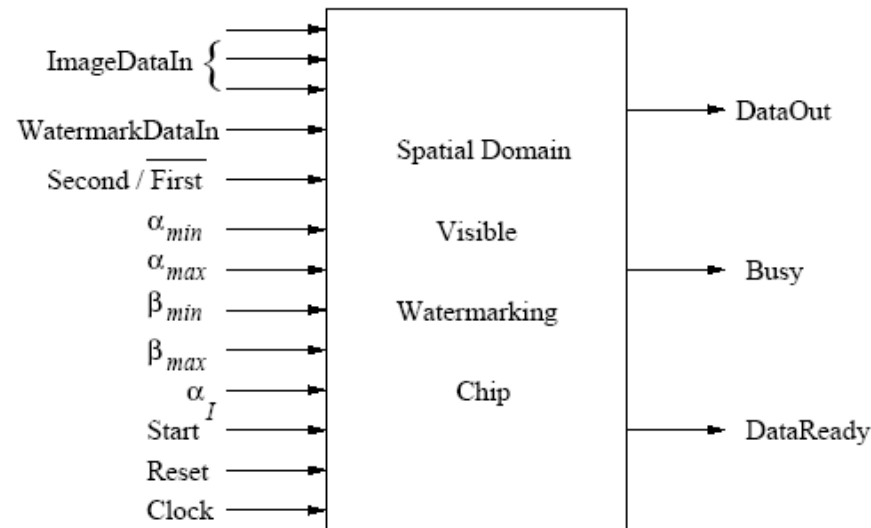

Pin Diagram

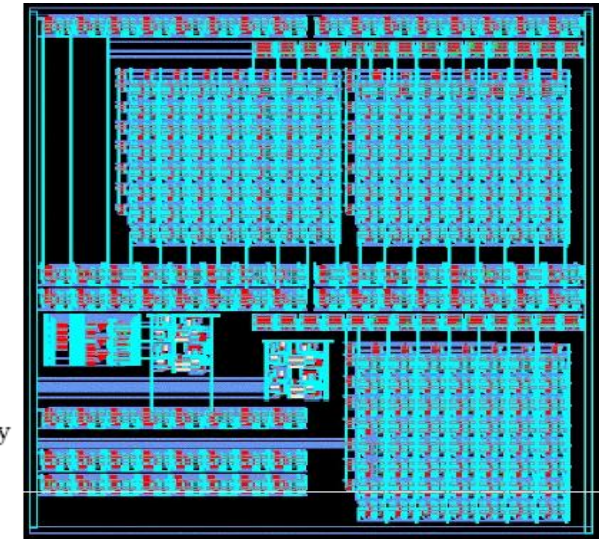

Chip Layout

Chip Design Data
 Total Area : 9.6 sq mm, No. of Gates: 28,469
 Power Consumption: 6.9 mW, Operating Frequency: 292 MHz

Source: **S. P. Mohanty**, N. Ranganathan, and R. K. Namballa, "A VLSI Architecture for Visible Watermarking in a Secure Still Digital Camera (S²DC) Design", *IEEE Transactions on Very Large Scale Integration Systems (TVLSI)*, Vol. 13, No. 8, August 2005, pp. 1002-1012.

Our Design: First Ever Watermarking Chip for Source-End Visual Data Integrity

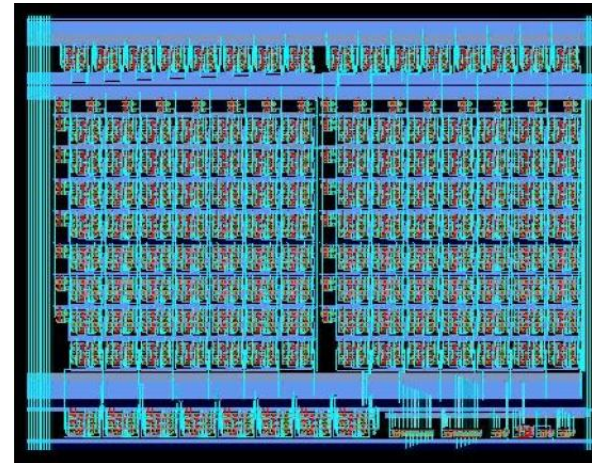
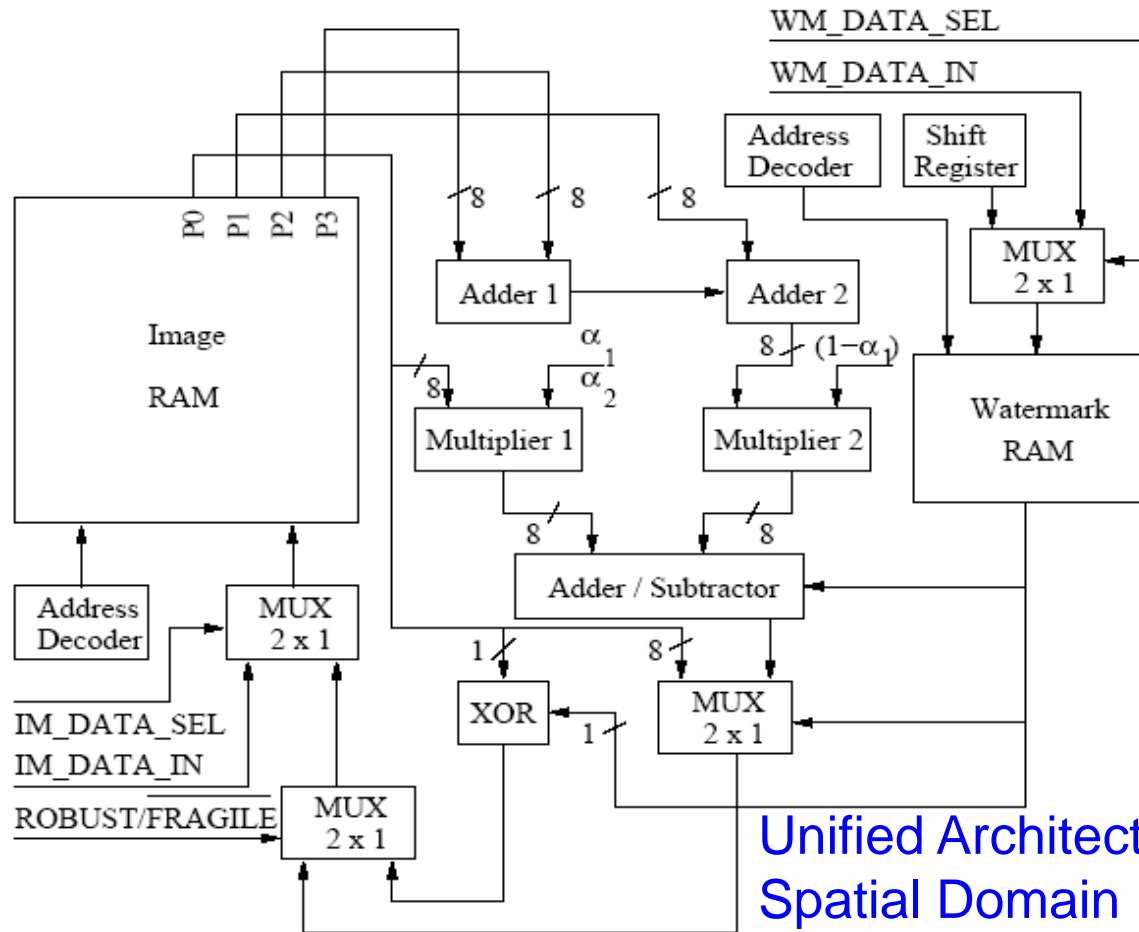

Chip Layout

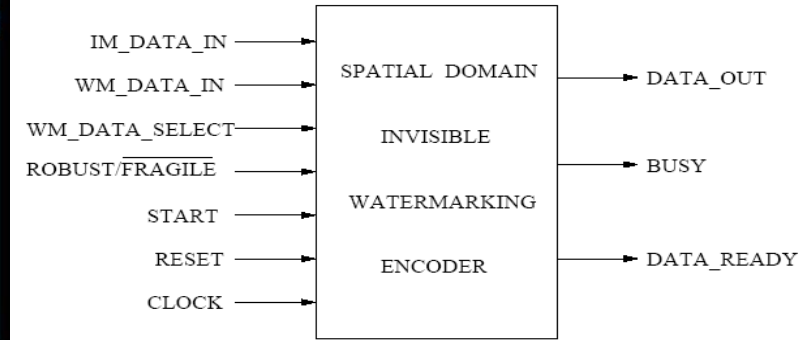

Pin Diagram

Chip Design Data
 Total Area : 0.87 sq mm, No. of Gates: 4,820
 Power Consumption: 2.0 mW, Frequency: 500 MHz

Unified Architecture for Spatial Domain Robust and Fragile Watermarking

Source: S. P. Mohanty, E. Kougianos, and N. Ranganathan, "VLSI Architecture and Chip for Combined Invisible Robust and Fragile Watermarking", *IET Computers & Digital Techniques (CDT)*, Sep 2007, Vol. 1, Issue 5, pp. 600-611.

Our Design: First Ever Low-Power Watermarking Chip for Data Quality

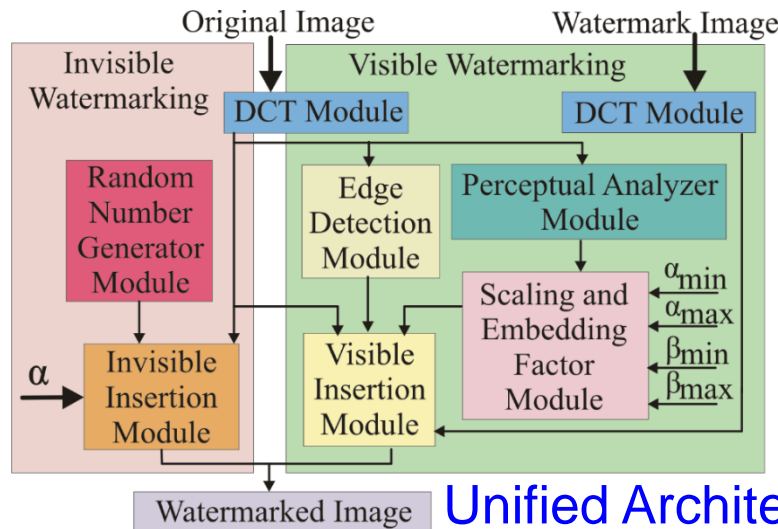

Unified Architecture for DCT Domain Watermarking

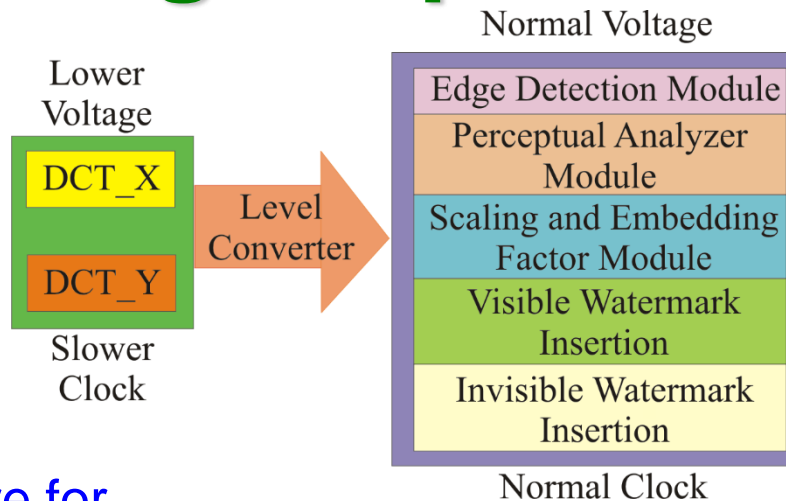

DVDF Low-Power Design

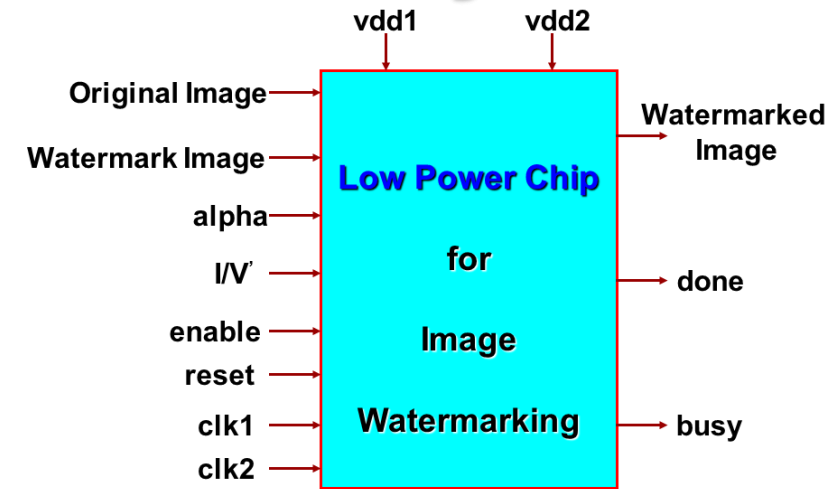

Pin Diagram

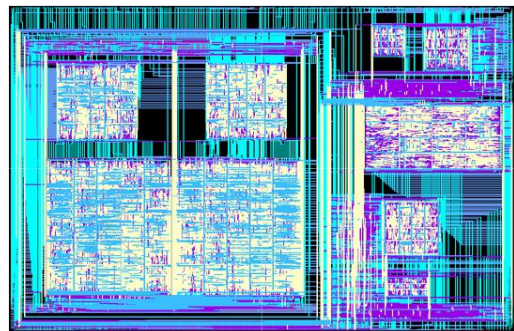

Chip Layout

Chip Design Data

Total Area : 16.2 sq mm, No. of Transistors: 1.4 million
 Power Consumption: 0.3 mW, Operating Frequency: 70 MHz and 250 MHz at 1.5 V and 2.5 V

Source: S. P. Mohanty, N. Ranganathan, and K. Balakrishnan, "A Dual Voltage-Frequency VLSI Chip for Image Watermarking in DCT Domain", *IEEE Transactions on Circuits and Systems II (TCAS-II)*, Vol. 53, No. 5, May 2006, pp. 394-398.

Our PUFshield: for Deepfake Mitigation Through PUF-Based Facial Feature Attestation ...

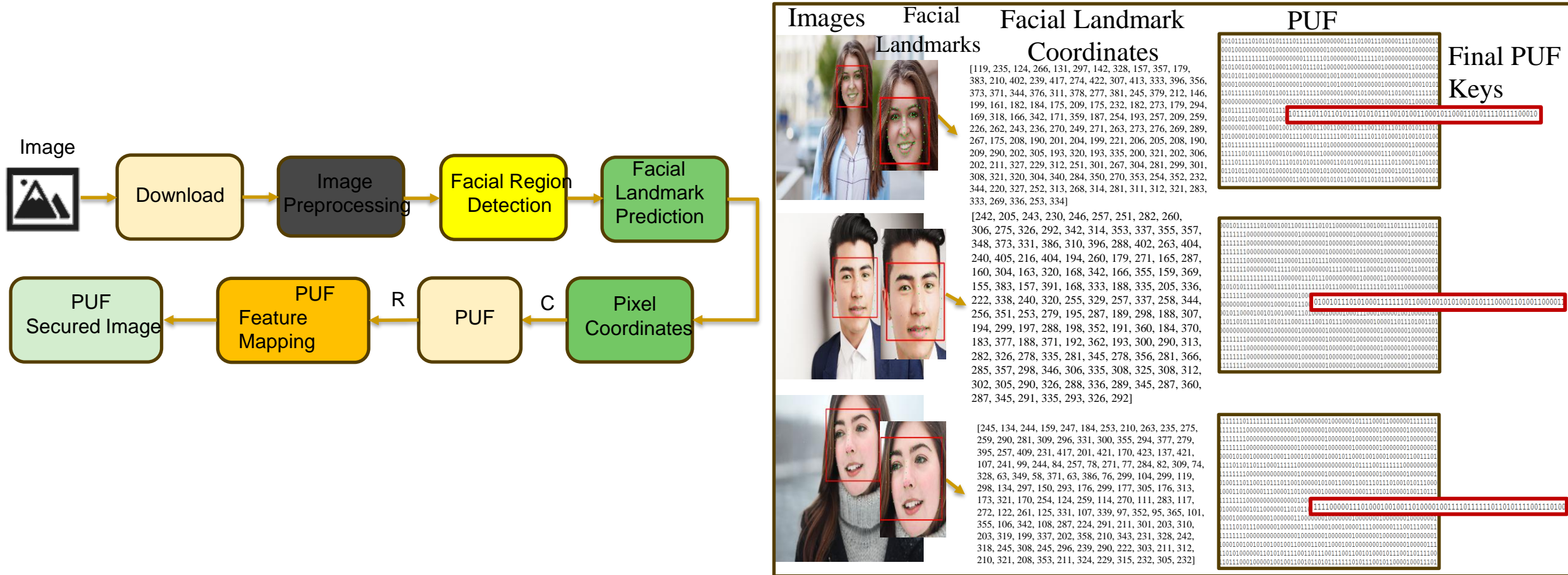

Source: V. K. V. V. Bathalapalli, V. P. Yanambaka, **S. P. Mohanty**, and E. Kougianos, "PUFshield: A Hardware-Assisted Approach for Deepfake Mitigation Through PUF-Based Facial Feature Attestation", in *Proceedings of the ACM Great Lakes Symposium on VLSI (GLSVLSI)*, 2024, pp. XXX--YYY, DOI: <https://doi.org/10.1145/3649476.3660394>.

Conclusion



Conclusion

- Cybersecurity is important problem in IoT-driven Cyber-Physical Systems (CPS) that build smart systems.
- Various elements and components of IoT/CPS including **Data, Devices, System Components**, AI need security.
- Both software and hardware-based attacks and solutions are possible for cybersecurity in IoT/CPS.
- Cybersecurity in IoT-based H-CPS, A-CPS, E-CPS, and T-CPS, IIoT, can have serious consequences.
- Existing cybersecurity solutions have **serious overheads** and may not even run in the end-devices (e.g. a medical device) of CPS/IoT.
- Security-by-Design (**SbD**) advocate features at early design phases, no-retrofitting.
- Hardware-Assisted Security (**HAS**): Cybersecurity provided by hardware for: (1) information being processed, (2) hardware itself, (3) overall system.

Future Directions

- Security by Design (PbD) needs significant research.
- Cybersecurity, Privacy, IP Protection of Information, Device, and System in Cyber-Physical Systems or CPS need more research.
- Cybersecurity of IoT-based systems (e.g. Smart Healthcare device/data, Smart Agriculture, Smart Grid, UAV, Smart Cars) needs research.
- Sustainable IoT and CPS with integrated cybersecurity features can provide robust solutions.
- More research is needed for robust, low-overhead PUF design and protocols that can be integrated in any CPS.
- Cybersecurity solutions for the quantum computing era for system needs attention.