

Towards Cyber-Fortifying the Smart Healthcare System

Keynote – 8th Students' Conference on Engineering and Systems (SCES 2024),
<http://mnnit.ac.in/sces2024/>

Prayagraj, India, 21--23 June 2024



Homepage:
www.smohanty.org

Prof./Dr. Saraju Mohanty
University of North Texas, USA.

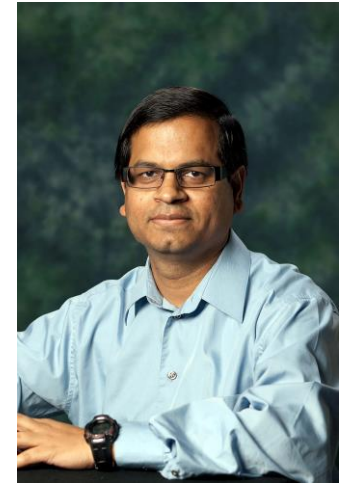

Outline

- Smart Healthcare – Broad Introduction
- Smart Healthcare – Challenges Against Sustainability
- Selected Cybersecurity Solutions for IoT/CPS
- Drawbacks of Existing Cybersecurity Solutions of IoMT/H-CPS
- Security by Design (SbD) Principle
- Security by Design (SbD) Example Solutions
- Trustworthy Pharmaceutical Supply Chain
- Trustworthy Medical Prescription
- Conclusion and Future Directions

Smart Healthcare – Broad Introduction

Human Body and Health

Human Body

- From an engineering perspective - Human body can be defined as a combination of multi-disciplinary subsystems (electrical, mechanical, chemical ...).

Health

- Human health is a state of complete physical, mental and social well-being.

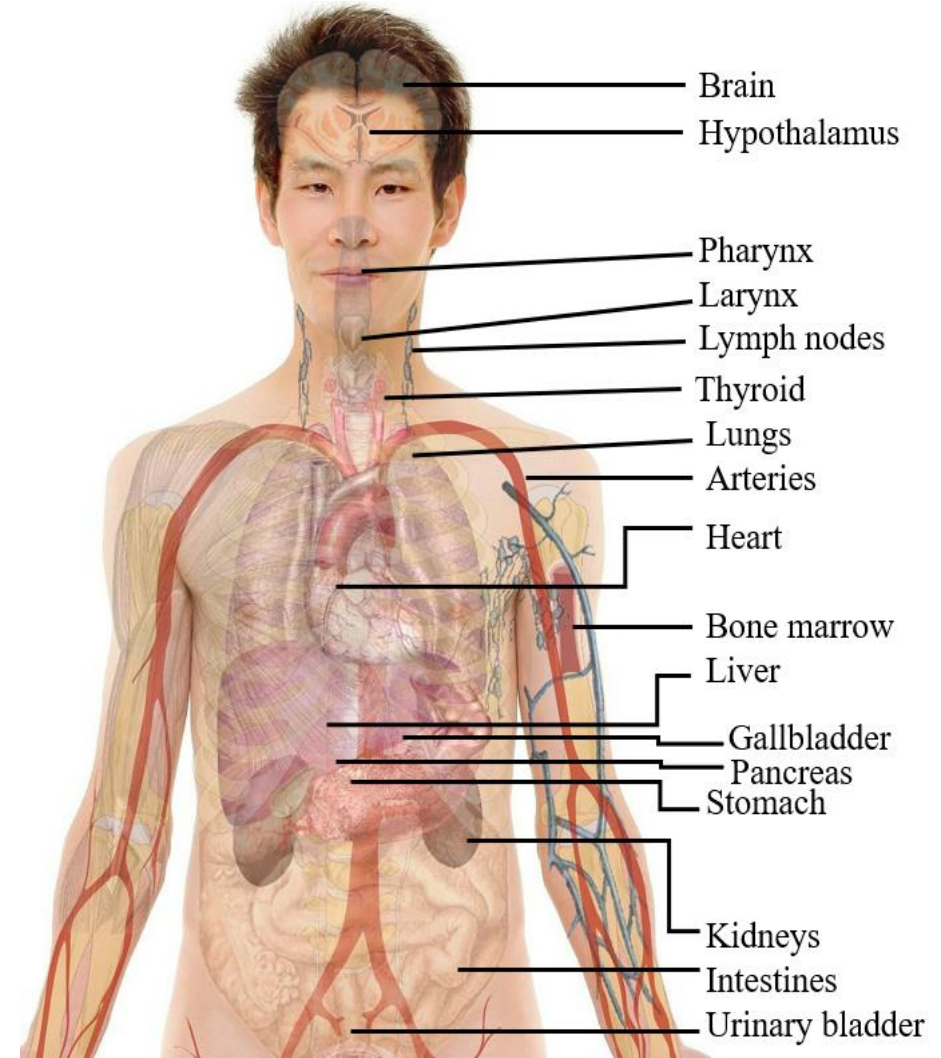

Traditional Healthcare

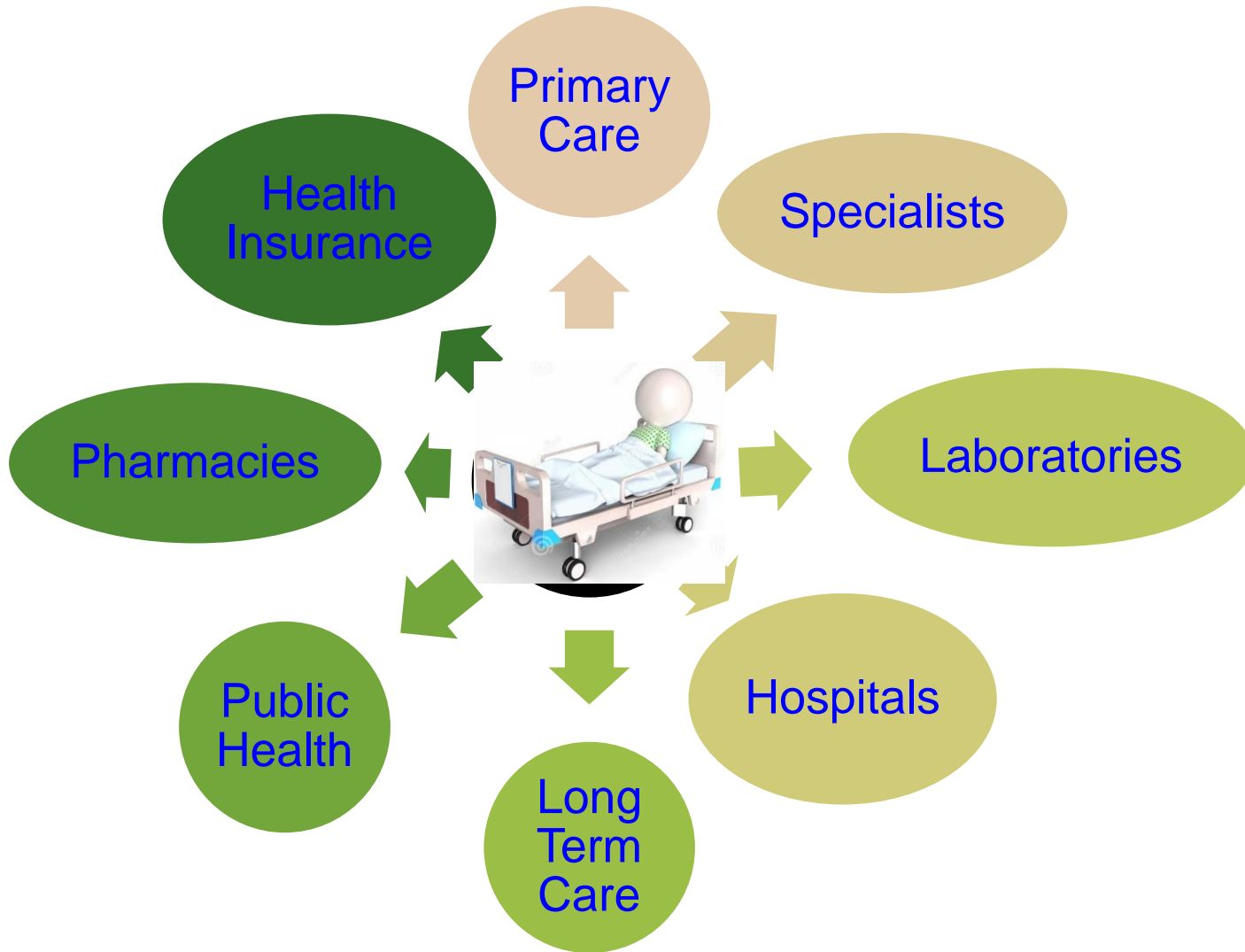

- Physical presence needed
- Deals with many stakeholders
- Stakeholders may not interact
- May not be personalized
- Not much active feedback
- Less effective follow-up from physicians

Healthcare → Smart Healthcare

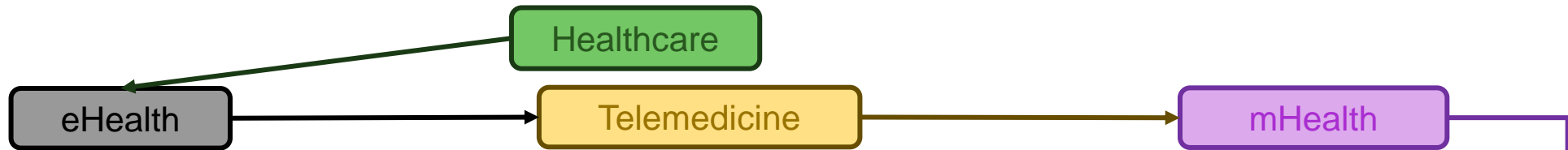

The use of information and communication technologies (ICT) to improve healthcare services.

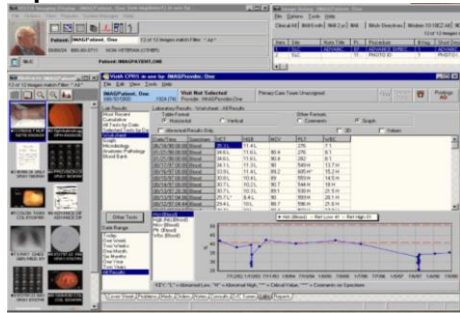

Telemedicine is the use of telecommunication and information technology to provide clinical healthcare from a distance.

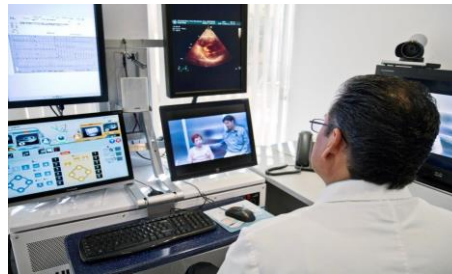

Healthcare supported by *mobile devices* that uses mobile telecommunications and multimedia technologies for the delivery of healthcare services and health information.



sHealth

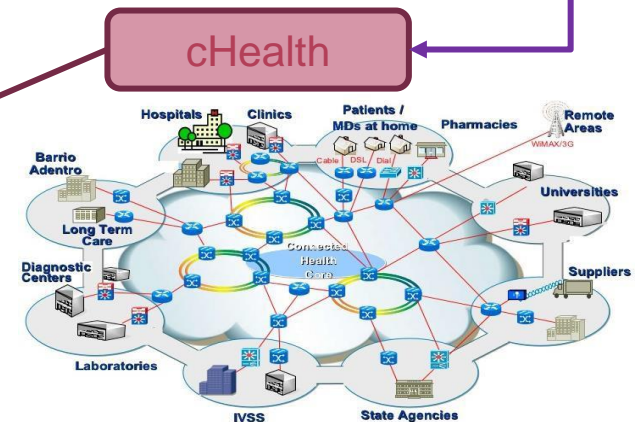

Source: S. P. Mohanty, "Smart Healthcare: From Healthcare to Smart Healthcare", ICCE 2020 Panel, Jan 2020.

Smart Healthcare (sHealth)

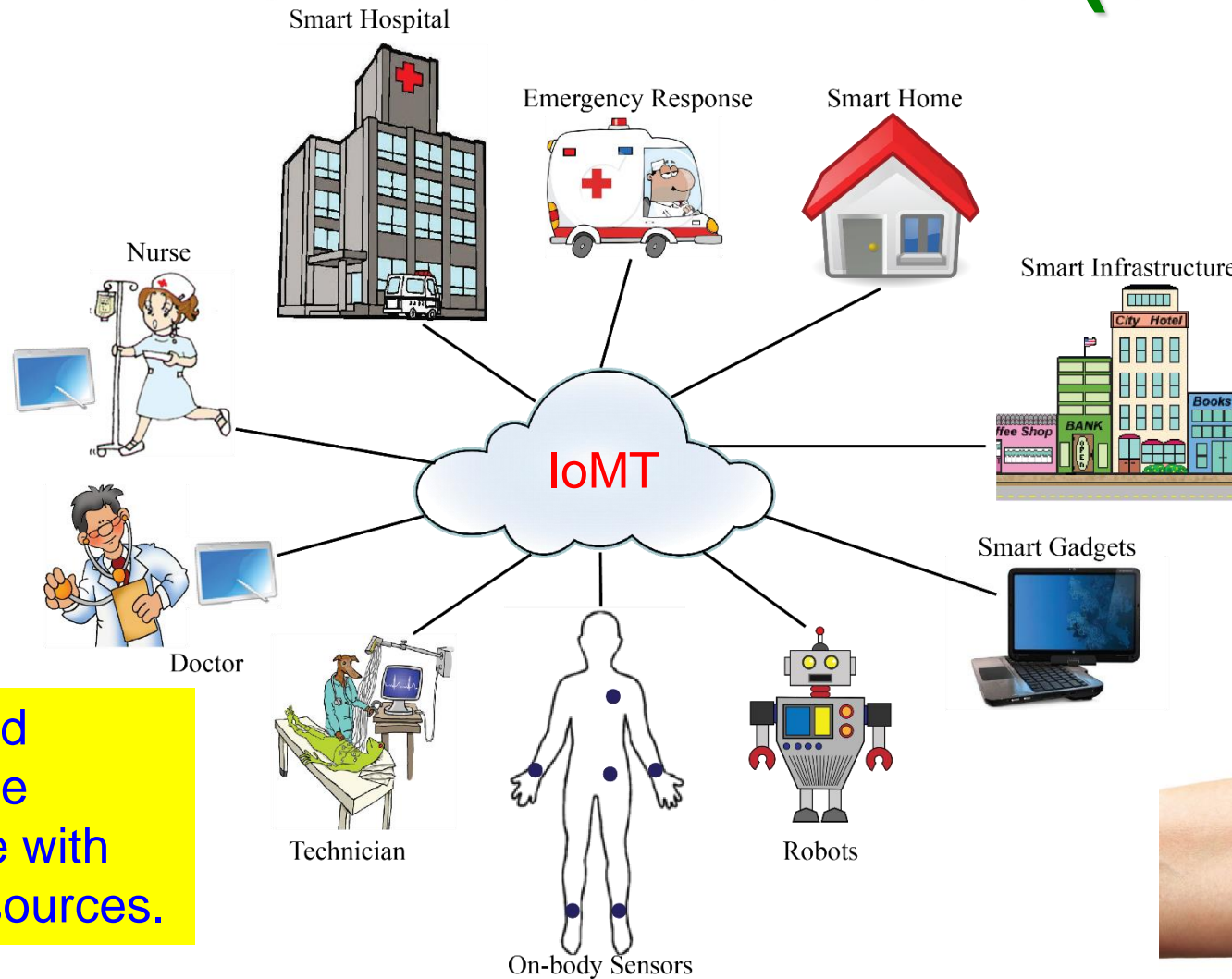

Fitness Trackers



Headband with Embedded Neurosensors

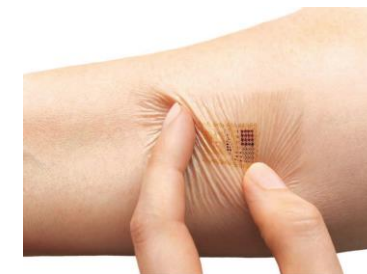

Embedded Skin Patches

Quality and sustainable healthcare with limited resources.

Source: P. Sundaravadivel, E. Kougianos, S. P. Mohanty, and M. Ganapathiraju, "Everything You Wanted to Know about Smart Health Care", *IEEE Consumer Electronics Magazine (MCE)*, Vol. 7, Issue 1, January 2018, pp. 18-28.

What is Smart Healthcare?

Smart Healthcare ←
Conventional Healthcare
+ Body sensors
+ Smart Technologies
+ Information & Communication Technology (ICT)
+ AI/ML

Internet of Medical Things (IoMT)

Internet of Health Things (IoHT)

Healthcare Cyber-Physical Systems (H-CPS)

Source: P. Sundaravadivel, E. Kougianos, S. P. Mohanty, and M. Ganapathiraju, "Everything You Wanted to Know about Smart Health Care", *IEEE Consumer Electronics Magazine (MCE)*, Volume 7, Issue 1, January 2018, pp. 18-28.

Smart Healthcare – Healthcare CPS

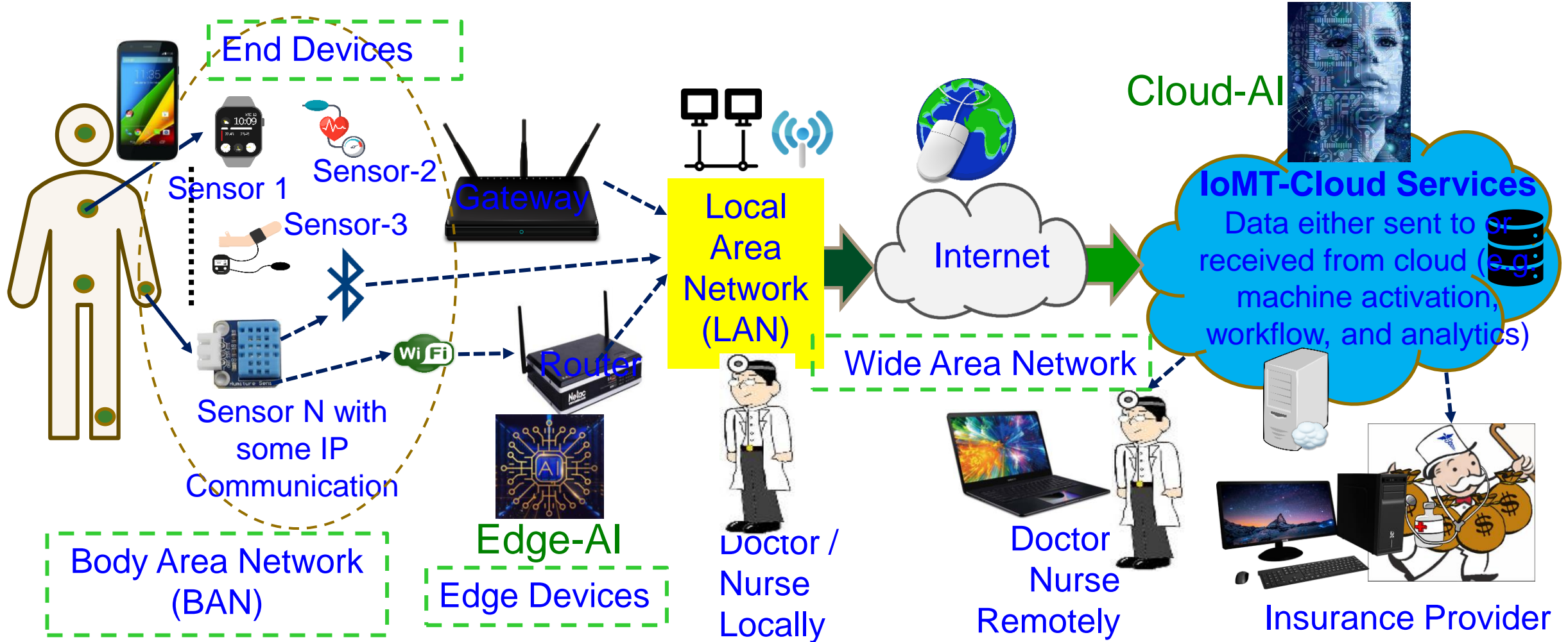

Frost and Sullivan predicts smart healthcare market value to reach US\$348.5 billion by 2025.

Source: S. P. Mohanty, Secure IoT by Design, Keynote, 4th IFIP International Internet of Things Conference (IFIP-IoT), 2021, Amsterdam, Netherlands, 5th November 2021.

Smart Healthcare – Challenges Against Sustainability

CPS – Sustainability Challenges

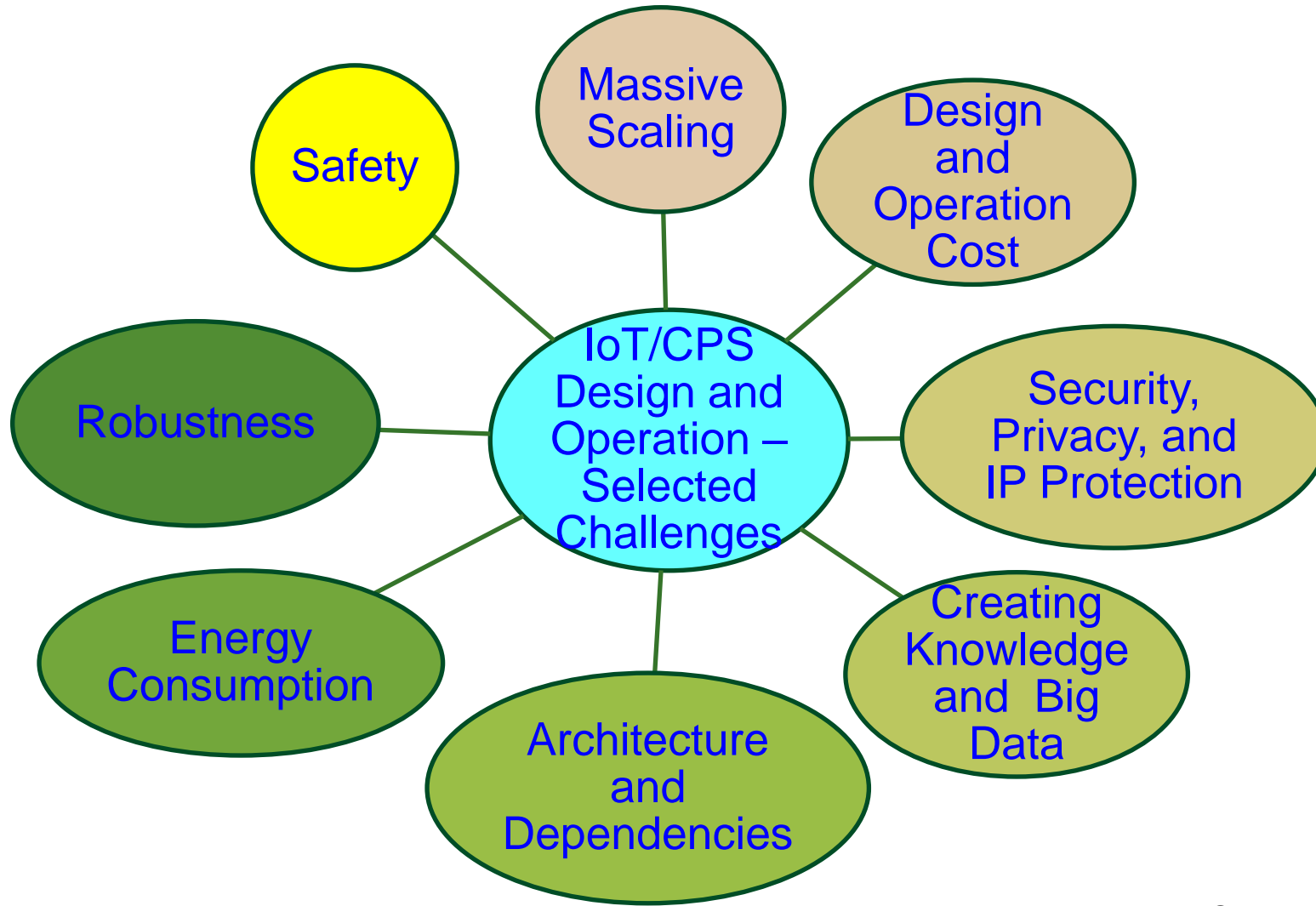

Source: Mohanty ICIT 2017 Keynote

Massive Growth of Sensors/Things

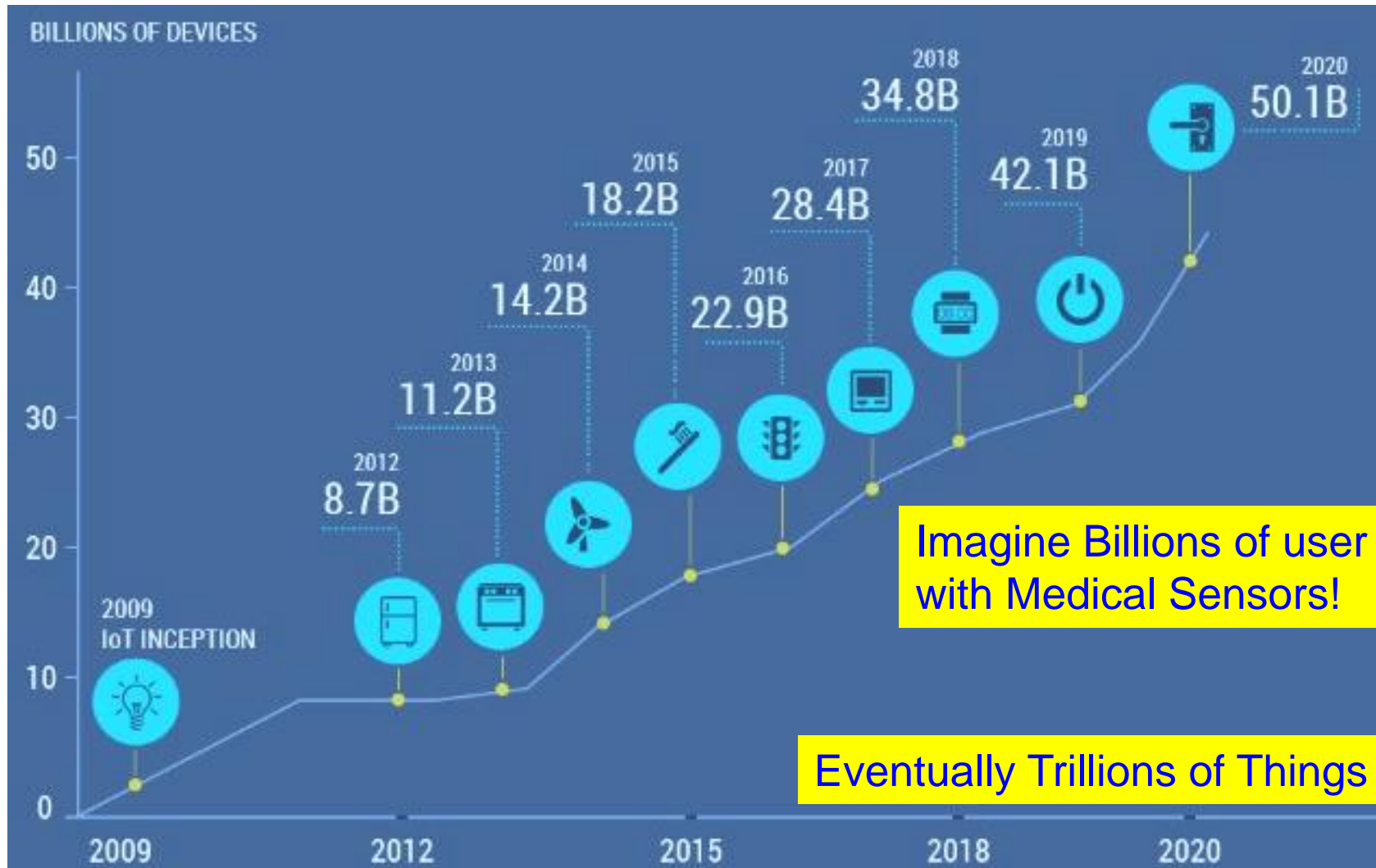

Imagine Billions of user with Medical Sensors!

Eventually Trillions of Things

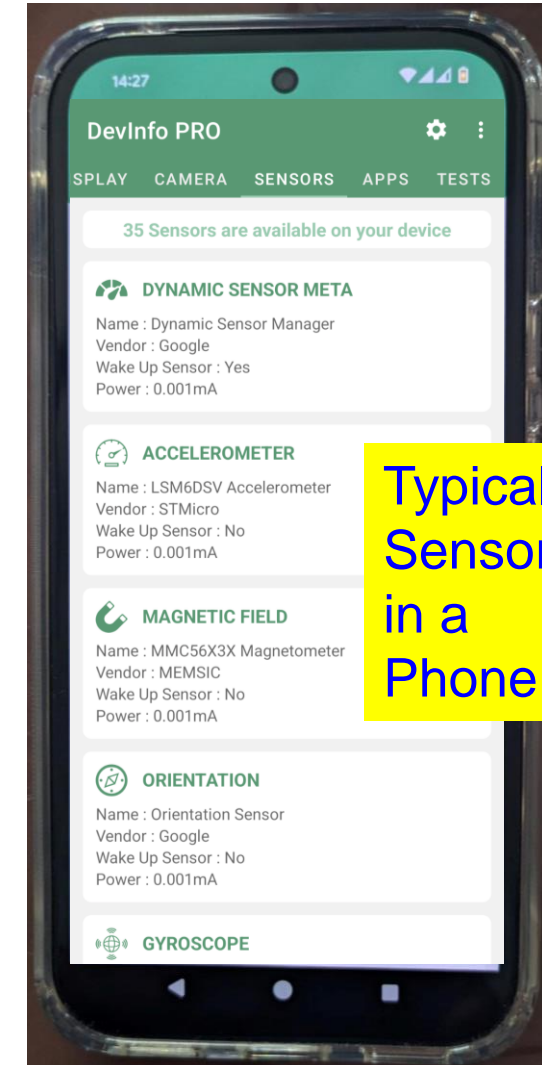

Source: <https://www.linkedin.com/pulse/history-iot-industrial-internet-sensors-data-lakes-0-downtime>

Challenges of Data in IoT/CPS are Multifold



Deep Neural Network (DNN) - Resource and Energy Costs

TRAIN: Iterate until you achieve satisfactory performance.

Needs Significant:

- Computational Resource
- Computation Energy

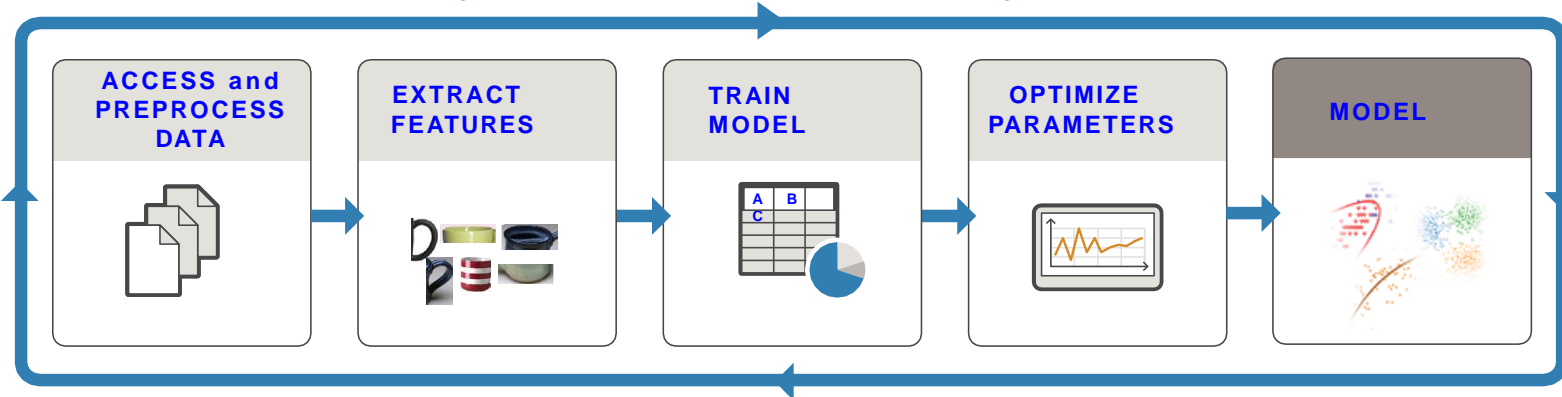

Limited Computational Capability
Limited Battery Life



PREDICT: Integrate trained models into applications.

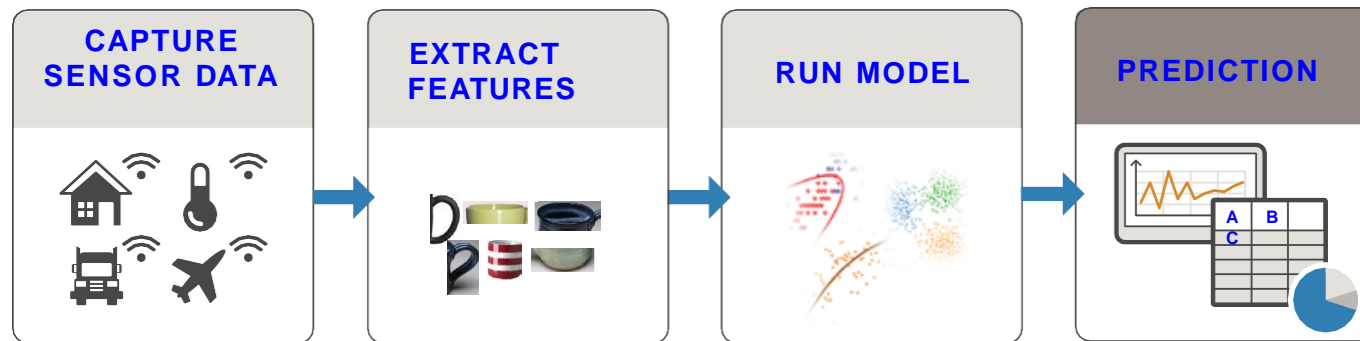

Needs:

- Computational Resource
- Computation Energy



Source: <https://www.mathworks.com/campaigns/offers/mastering-machine-learning-with-matlab.html>

AI/ML – Cybersecurity Issue

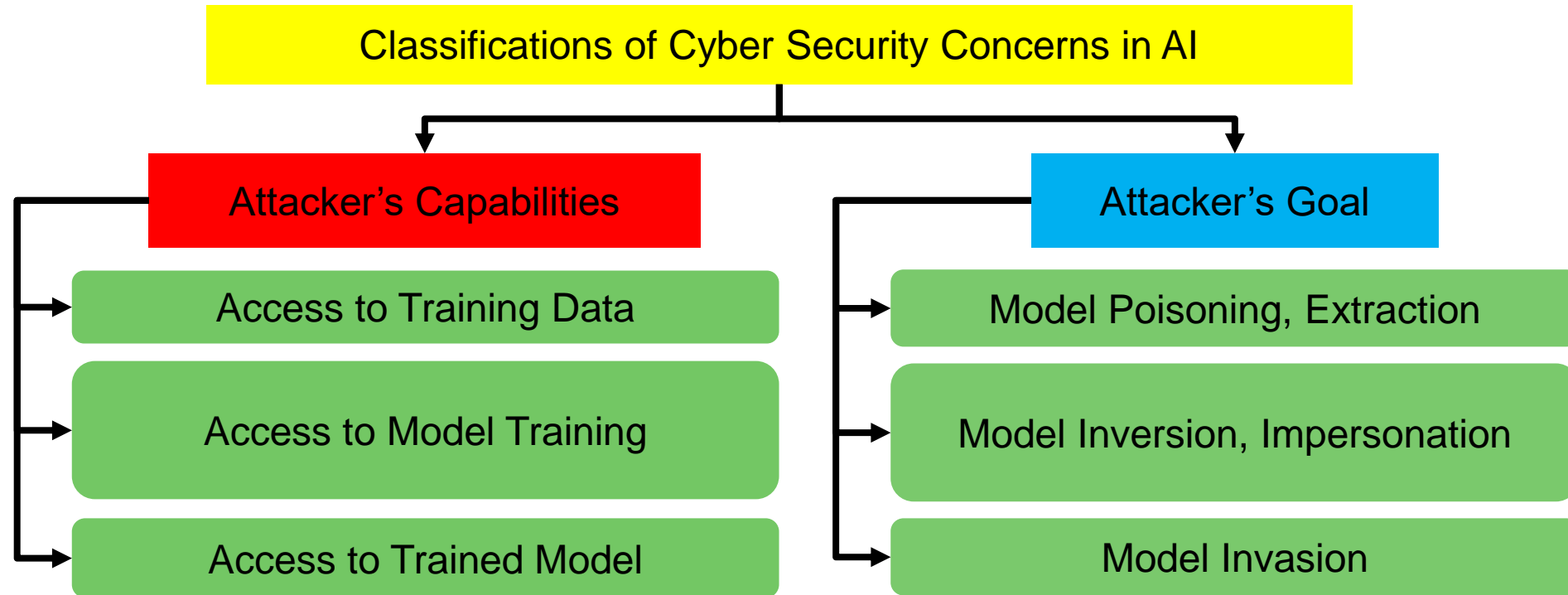

Source: D. Puthal, and **S. P. Mohanty**, “[Cybersecurity Issues in AI](#)”, *IEEE Consumer Electronics Magazine (MCE)*, Vol. 10, No. 4, July 2021, pp. 33--35.

Wrong ML Model → Wrong Diagnosis

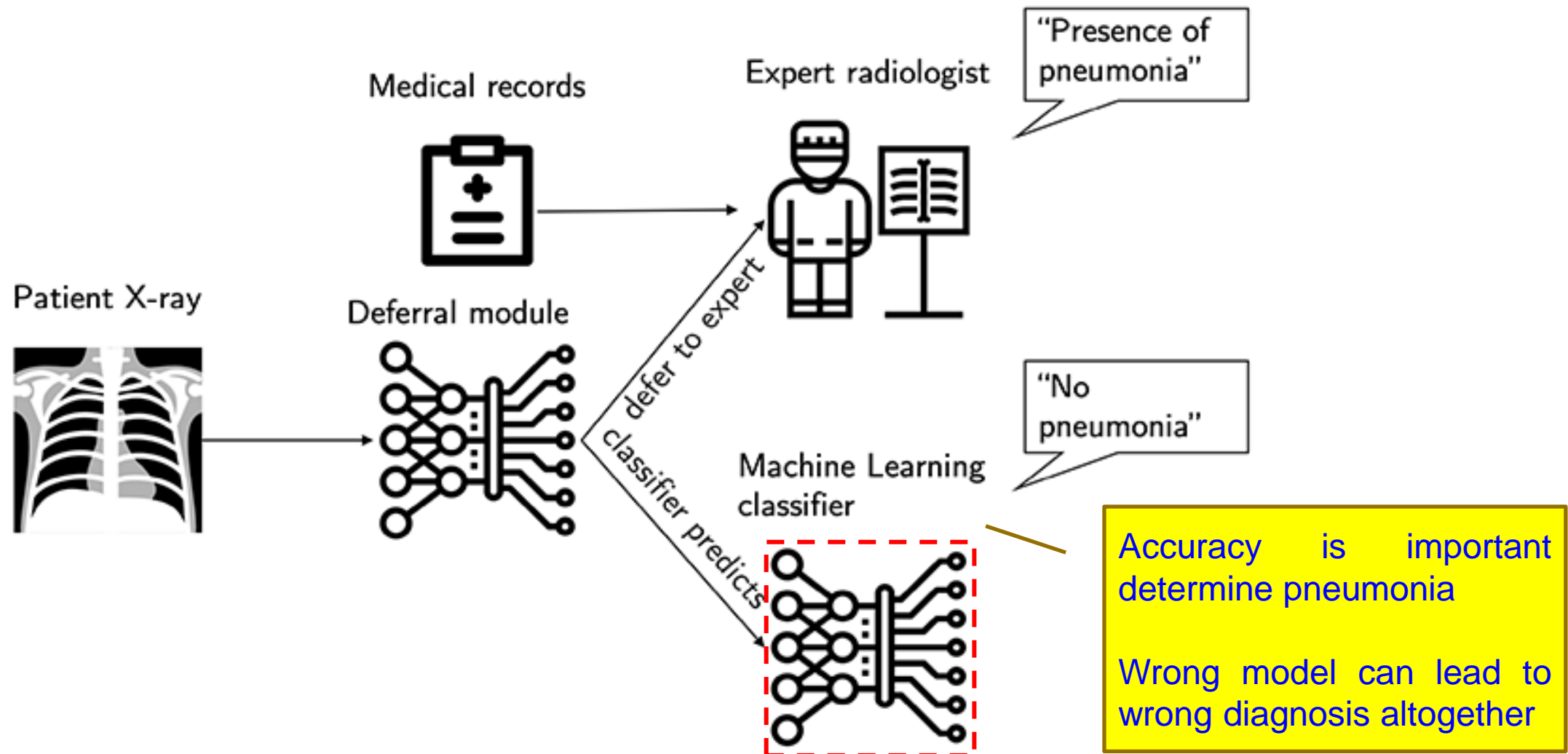

Source: <https://www.healthcareitnews.com/news/new-ai-diagnostic-tool-knows-when-defer-human-mit-researchers-say>

Smart Healthcare - Security Challenges



Selected Smart Healthcare Security/Privacy Challenges

- Data Eavesdropping
- Data Confidentiality
- Data Privacy
- Data Integrity
- Identity Threats
- Unique Identification
- Personal Privacy
- Location Privacy
- Access Control
- Device Security

Source: P. Sundaravadivel, E. Kougianos, S. P. Mohanty, and M. Ganapathiraju, "Everything You Wanted to Know about Smart Health Care", *IEEE Consumer Electronics Magazine (CEM)*, Volume 7, Issue 1, January 2018, pp. 18-28.

Implantable Medical Devices - Attacks



- The vulnerabilities affect implantable cardiac devices and the external equipment used to communicate with them.
- The devices emit RF signals that can be detected up to several meters from the body.
- A malicious individual nearby could conceivably hack into the signal to jam it, alter it, or snoop on it.

Source: Emily Waltz, Can "Internet-of-Body" Thwart Cyber Attacks on Implanted Medical Devices?, *IEEE Spectrum*, 28 Mar 2019, <https://spectrum.ieee.org/the-human-os/biomedical/devices/thwart-cyber-attacks-on-implanted-medical-devices.amp.html>.

Fake Data and Fake Hardware – Both are Equally Dangerous in CPS

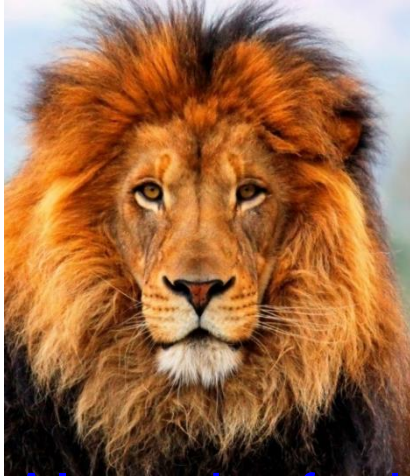

AI can be fooled by fake data



AI can create fake data (Deepfake)



Authentic

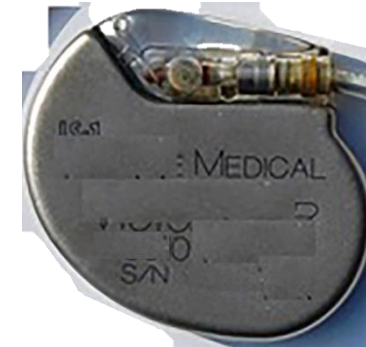

Fake

An implantable medical device



Authentic



Fake

A plug-in for car-engine computers

Fake is Cheap – Why not Buy?



Is my Pacemaker Authentic or Fake?

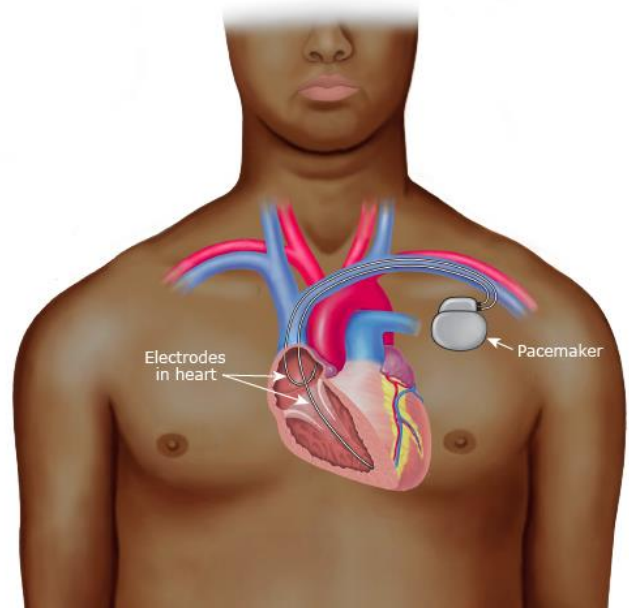

International Pharmaceutical Students' Federation
Asia Pacific Regional Office

THE NEGATIVE IMPACTS OF FAKE MEDICINE

- Increased mortality and morbidity
- Development of drug resistance
- Increase the chance of adverse effects
- Loss of confidence in health systems and health workers
- Undermining of drug research and development
- Crowding out of legitimate drug manufacturers
- Decreased willingness of patients to accept treatment
- Economic loss for patients and health systems

Source: <https://apro.ipssf.org/>

Electronic Health Records (EHR's)

- Electronic Health Record (EHR) is an electronic version of patient medical history maintained by the provider
- Contains demographics, progress notes, problems, medications, and other administrative information

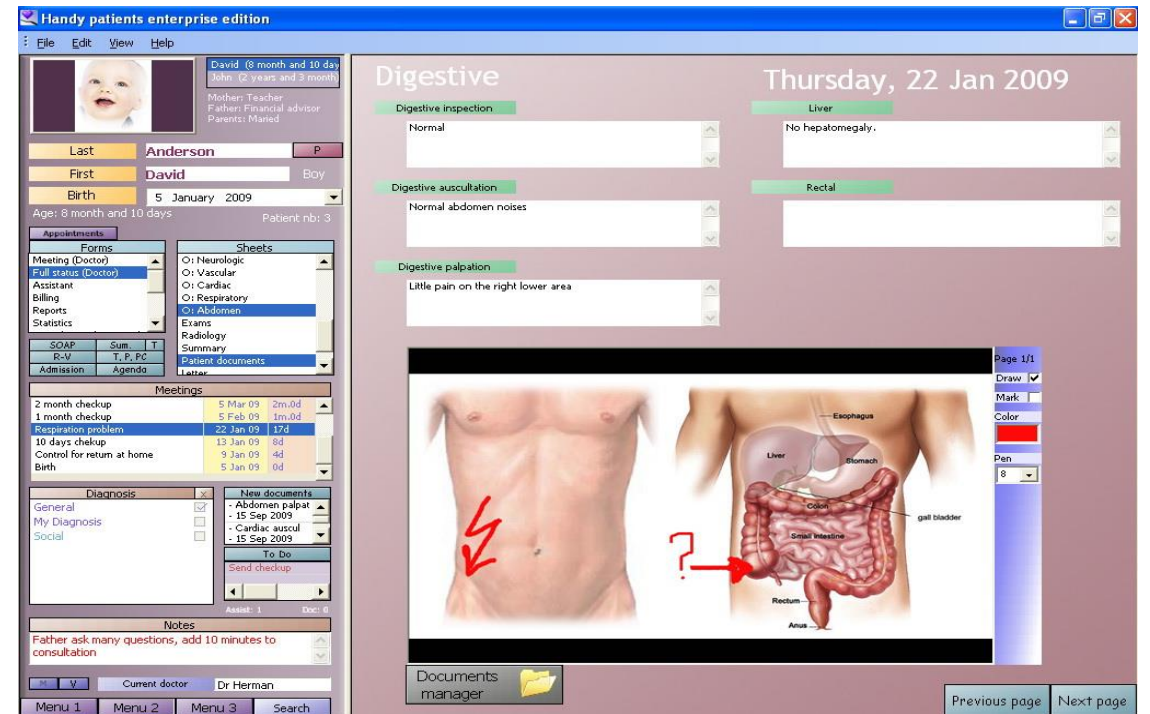
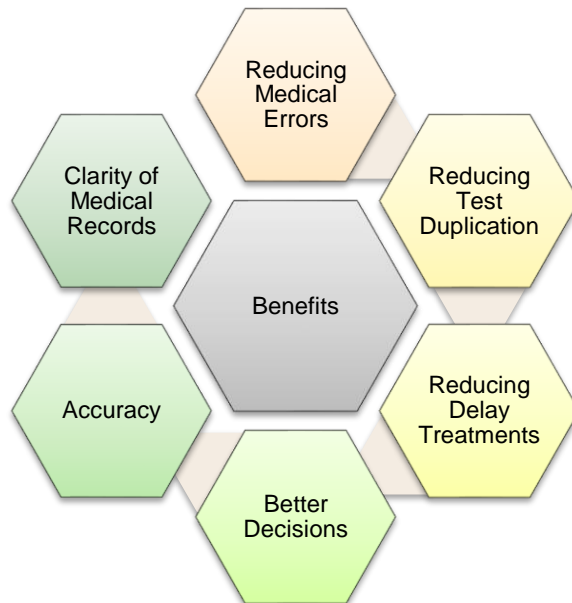
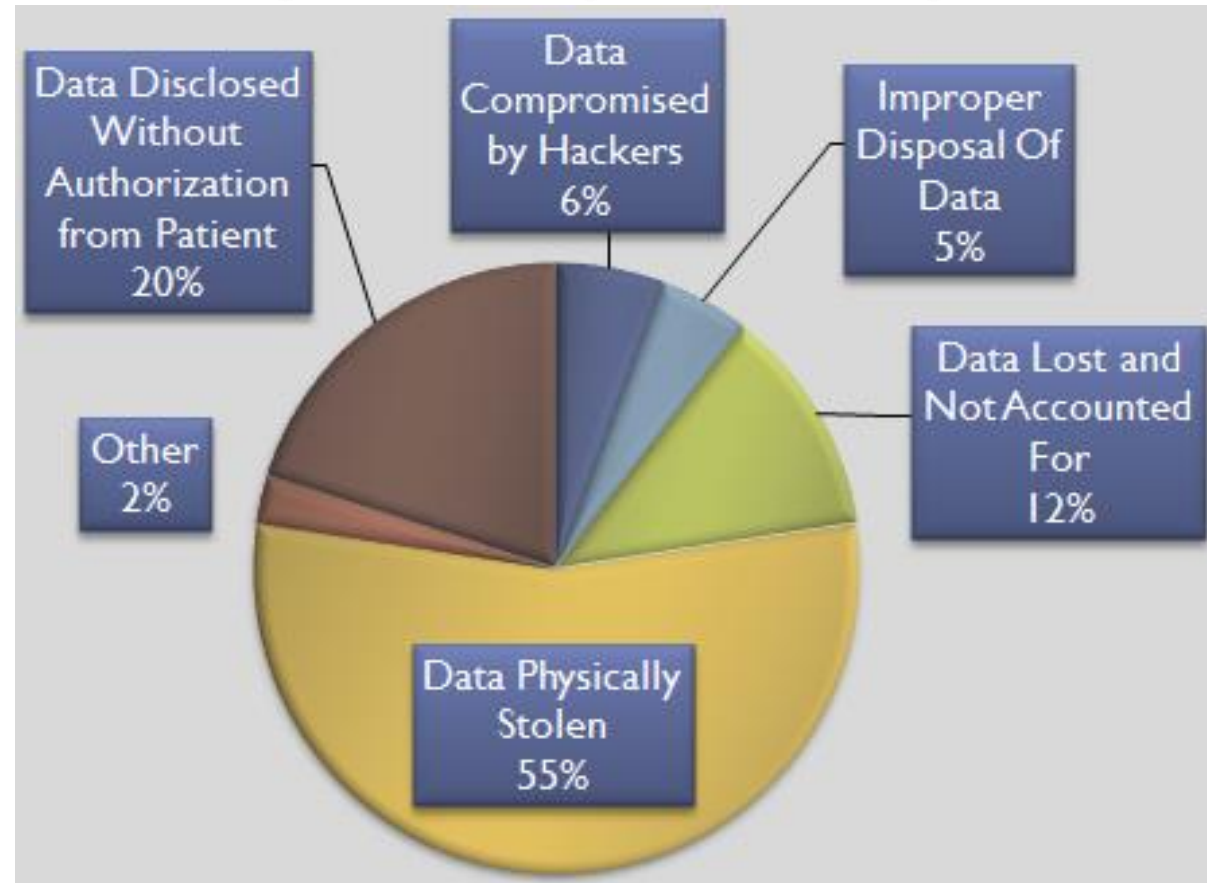

Image Source: DaCarpenter, An electronic medical record example, Handy patients electronic medical record (free open-source version)

Health Insurance Portability and Accountability Act (HIPAA)



HIPPA Privacy Violation by Types

Cybrsecurity Solution for IoT/CPS



Smart Healthcare Cybersecurity

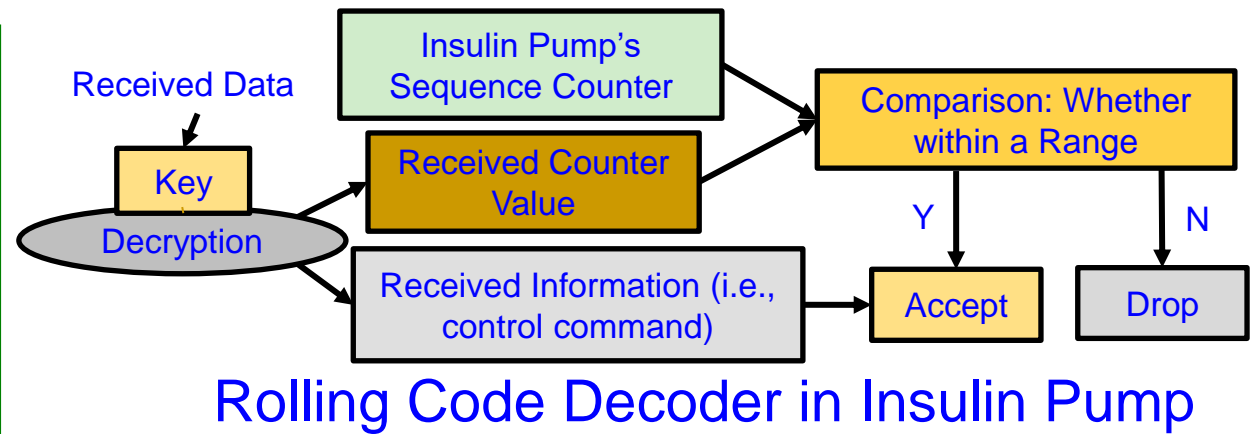
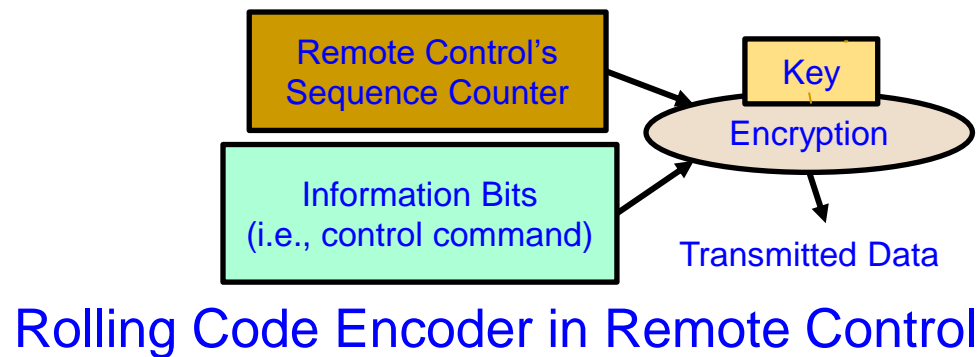
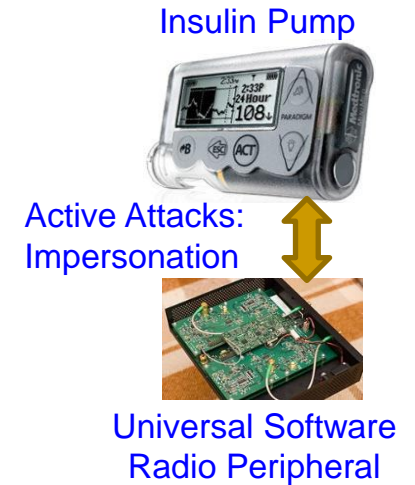
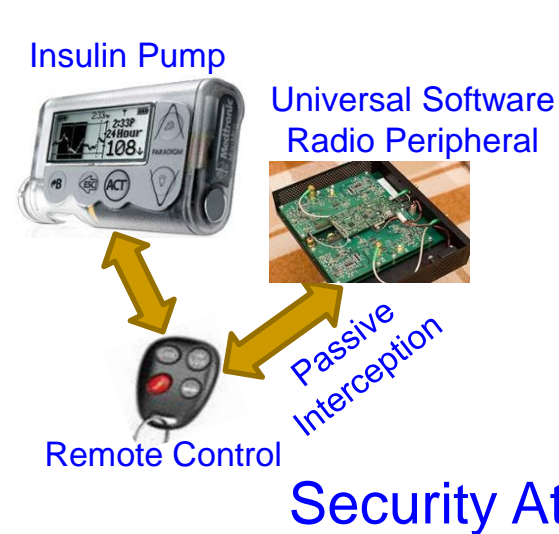

Source: Li and Jha 2011: HEALTH 2011

Blockchain in Smart Healthcare

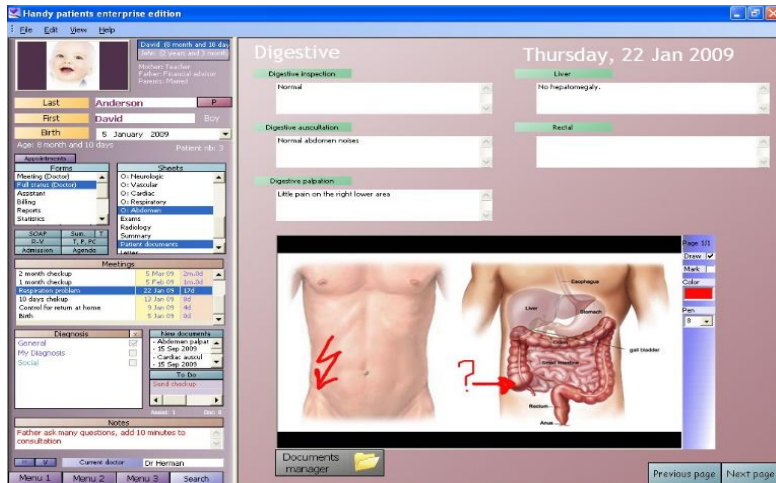
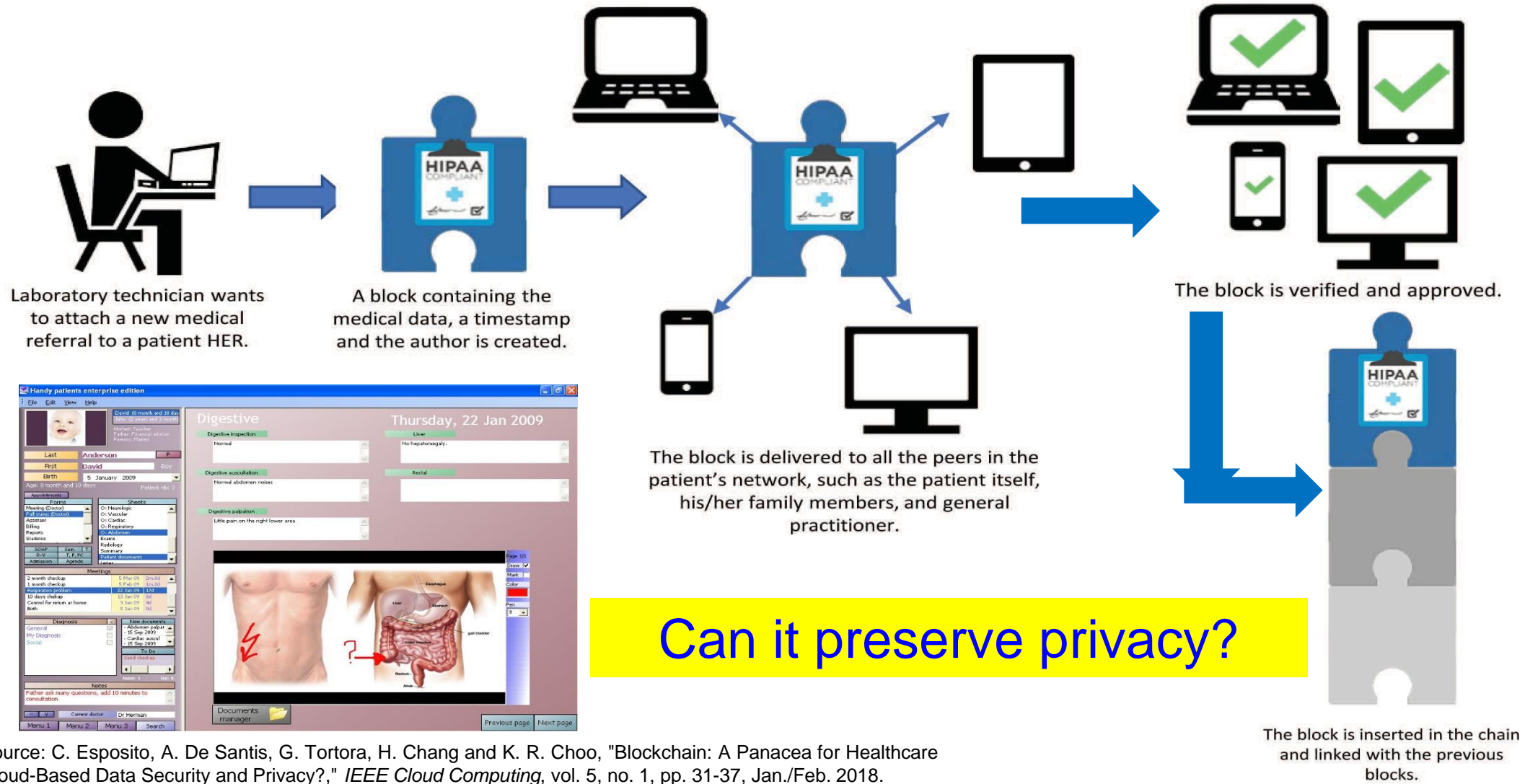

Can it preserve privacy?

Source: C. Esposito, A. De Santis, G. Tortora, H. Chang and K. R. Choo, "Blockchain: A Panacea for Healthcare Cloud-Based Data Security and Privacy?," *IEEE Cloud Computing*, vol. 5, no. 1, pp. 31-37, Jan./Feb. 2018.

Nonvolatile Memory Security and Protection



Source: <http://datalocker.com>

Nonvolatile / Harddrive Storage

Hardware-based encryption of data secured/protected by strong password/PIN authentication.

Software-based encryption to secure systems and partitions of hard drive.

Some performance penalty due to increase in latency!

How Cloud storage changes this scenario?

Our Swing-Pay - NFC Cybersecurity Solution

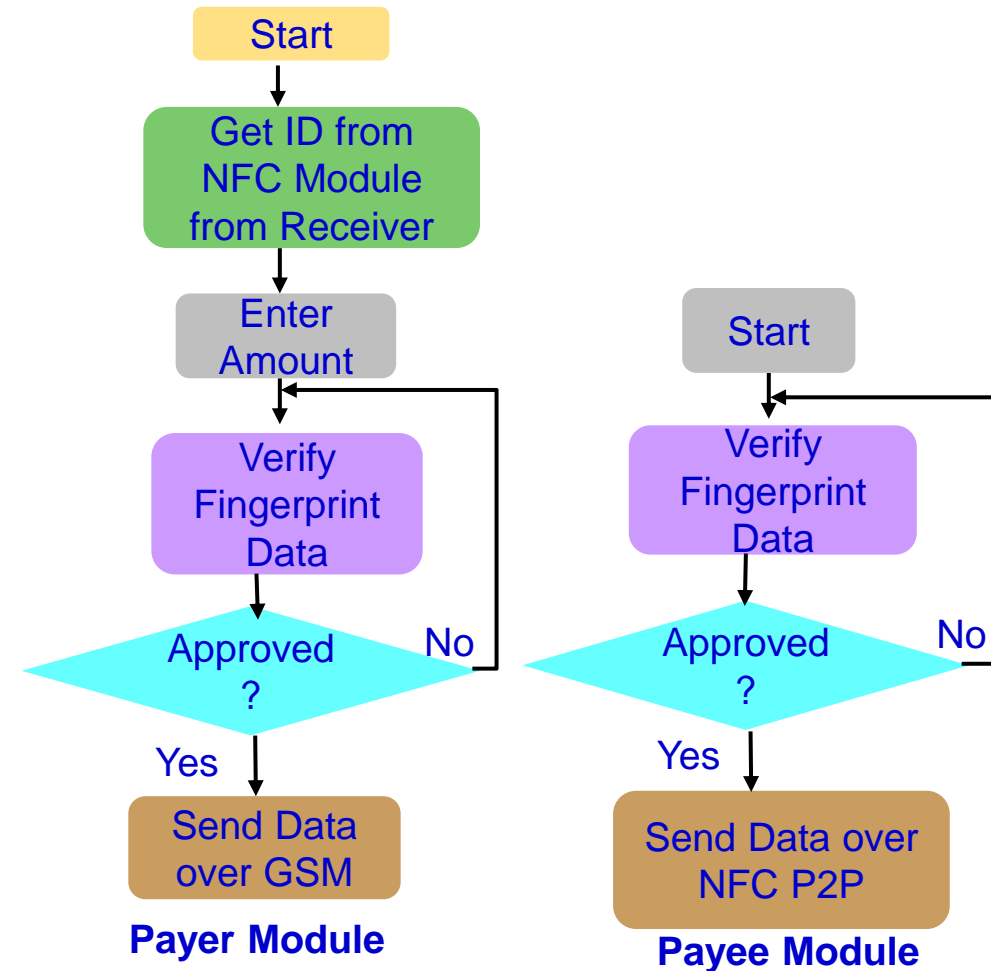
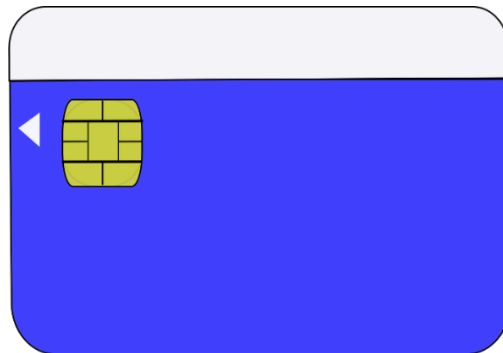
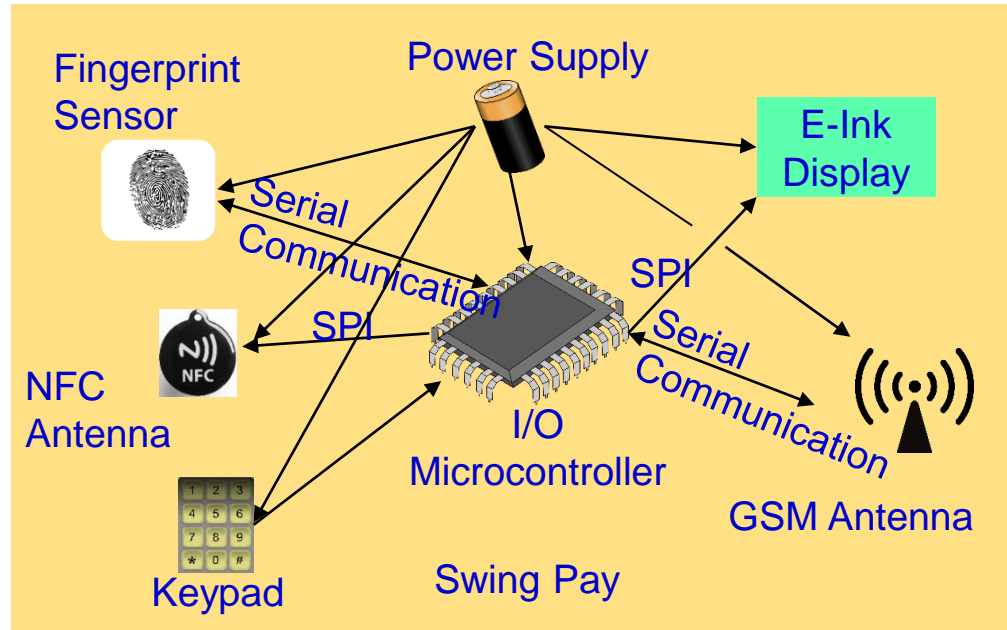

Source: S. Ghosh, J. Goswami, A. Majumder, A. Kumar, **S. P. Mohanty**, and B. K. Bhattacharyya, "Swing-Pay: One Card Meets All User Payment and Identity Needs", *IEEE Consumer Electronics Magazine (MCE)*, Volume 6, Issue 1, January 2017, pp. 82--93.

Drawbacks of Existing Cybersecurity Solutions



IT Cybersecurity Solutions Can't be Directly Extended to IoT/CPS Cybersecurity

IT Cybersecurity

- IT infrastructure may be well protected rooms
- Limited variety of IT network devices
- Millions of IT devices
- Significant computational power to run heavy-duty security solutions
- IT security breach can be costly

IoT Cybersecurity

- IoT may be deployed in open hostile environments
- Significantly large variety of IoT devices
- Billions of IoT devices
- May not have computational power to run security solutions
- IoT security breach (e.g. in a IoMT device like pacemaker, insulin pump) can be life threatening

Maintaining of Cybersecurity of Electronic Systems, IoT, CPS, needs **Energy**, and affects performance.

Cybersecurity Measures in Healthcare Cyber-Physical Systems is Hard

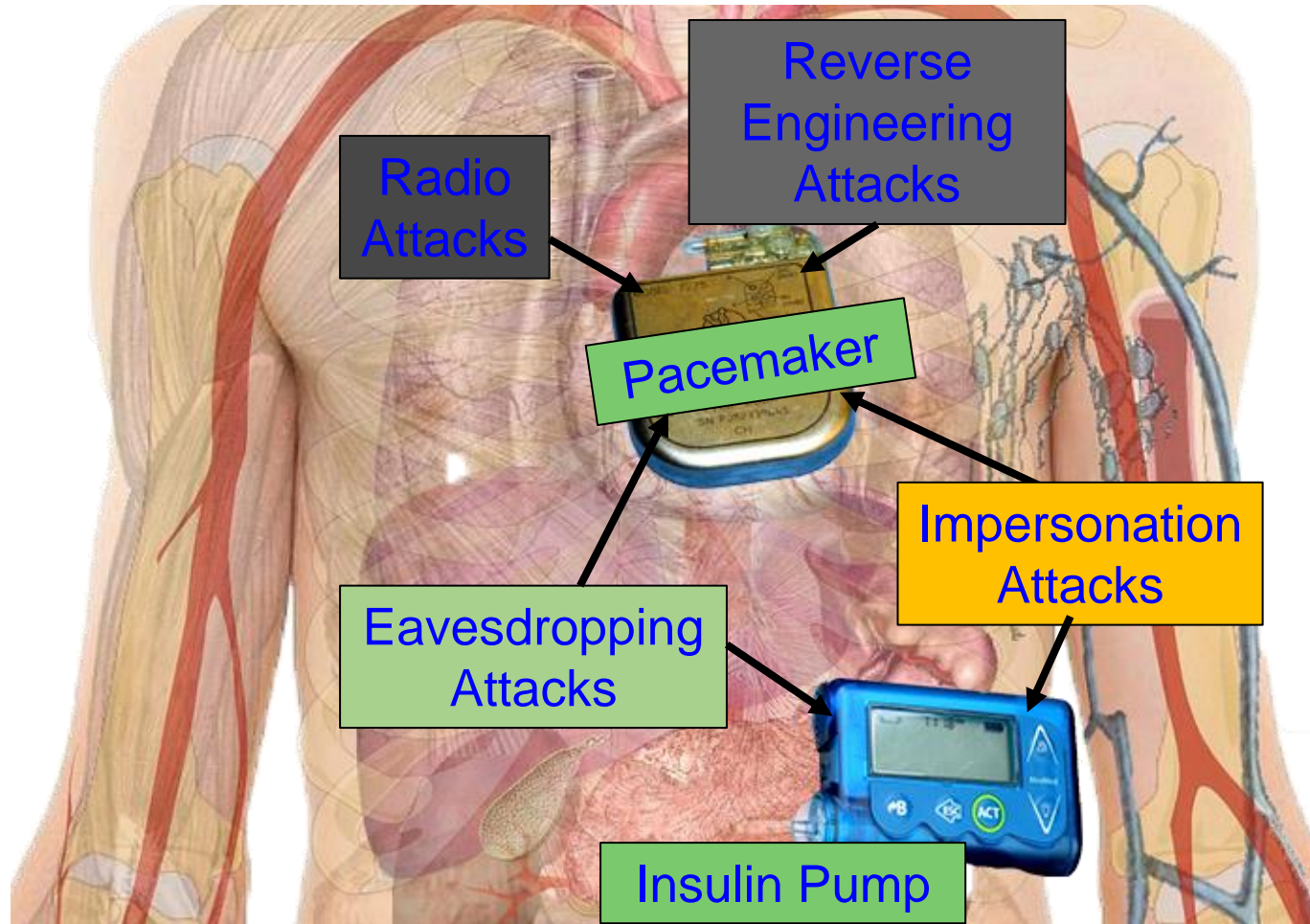

Collectively (WMD+IMD):
Implantable and Wearable
Medical Devices (IWMDs)

Implantable and Wearable Medical
Devices (IWMDs):

- Longer Battery life
- Safer device
- Smaller size
- Smaller weight
- Not much computational capability

H-CPS Cybersecurity Measures is Hard - Energy Constrained

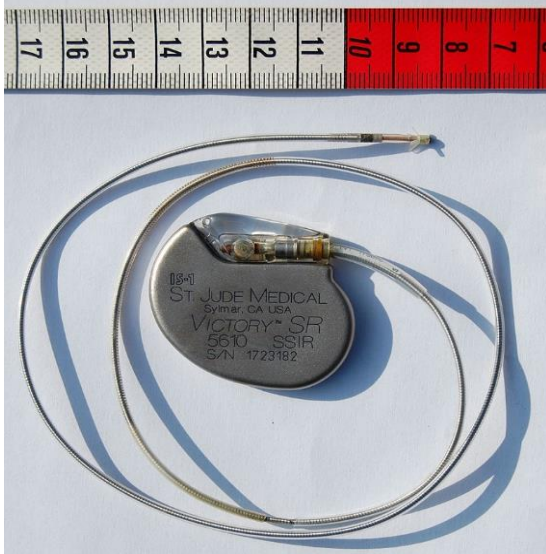

Pacemaker
Battery Life
- 10 years



Neurostimulator
Battery Life
- 8 years

- Implantable Medical Devices (IMDs) have integrated battery to provide energy to all their functions → Limited Battery Life depending on functions
- Higher battery/energy usage → Lower IMD lifetime
- Battery/IMD replacement → Needs surgical risky procedures

Source: C. Camara, P. Peris-Lopez, and J. E.Tapiadora, "Security and privacy issues in implantable medical devices: A comprehensive survey", *Elsevier Journal of Biomedical Informatics*, Volume 55, June 2015, Pages 272-289.

Cybersecurity Attacks – Software Vs Hardware Based

Software Based

- Software attacks via communication channels
- Typically from remote
- More frequent
- Selected Software based:
 - ❑ Denial-of-Service (DoS)
 - ❑ Routing Attacks
 - ❑ Malicious Injection
 - ❑ Injection of fraudulent packets
 - ❑ Snooping attack of memory
 - ❑ Spoofing attack of memory and IP address
 - ❑ Password-based attacks



Hardware Based

- Hardware or physical attacks
- Maybe local
- More difficult to prevent
- Selected Hardware based:
 - ❑ Hardware backdoors (e.g. Trojan)
 - ❑ Inducing faults
 - ❑ Electronic system tampering/ jailbreaking
 - ❑ Eavesdropping for protected memory
 - ❑ Side channel attack
 - ❑ Hardware counterfeiting

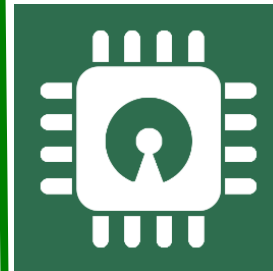

Source: Mohanty ICCE Panel 2018

Cybersecurity Solutions – Software Vs Hardware Based

Software Based



- Introduces latency in operation
- Flexible - Easy to use, upgrade and update
- Wider-Use - Use for all devices in an organization
- Higher recurring operational cost
- Tasks of encryption easy compared to hardware – substitution tables
- Needs general purpose processor
- Can't stop hardware reverse engineering

Source: Mohanty ICCE Panel 2018

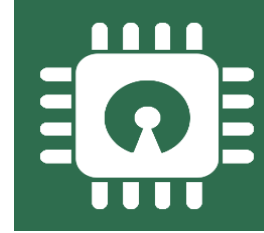

Hardware Based

- High-Speed operation
- Energy-Efficient operation
- Low-cost using ASIC and FPGA
- Tasks of encryption easy compared to software – bit permutation
- Easy integration in CE systems
- Possible security at source-end like sensors, better suitable for IoT
- Susceptible to side-channel attacks
- Can't stop software reverse engineering

CPS Design - Multiple Objectives for Sustainability

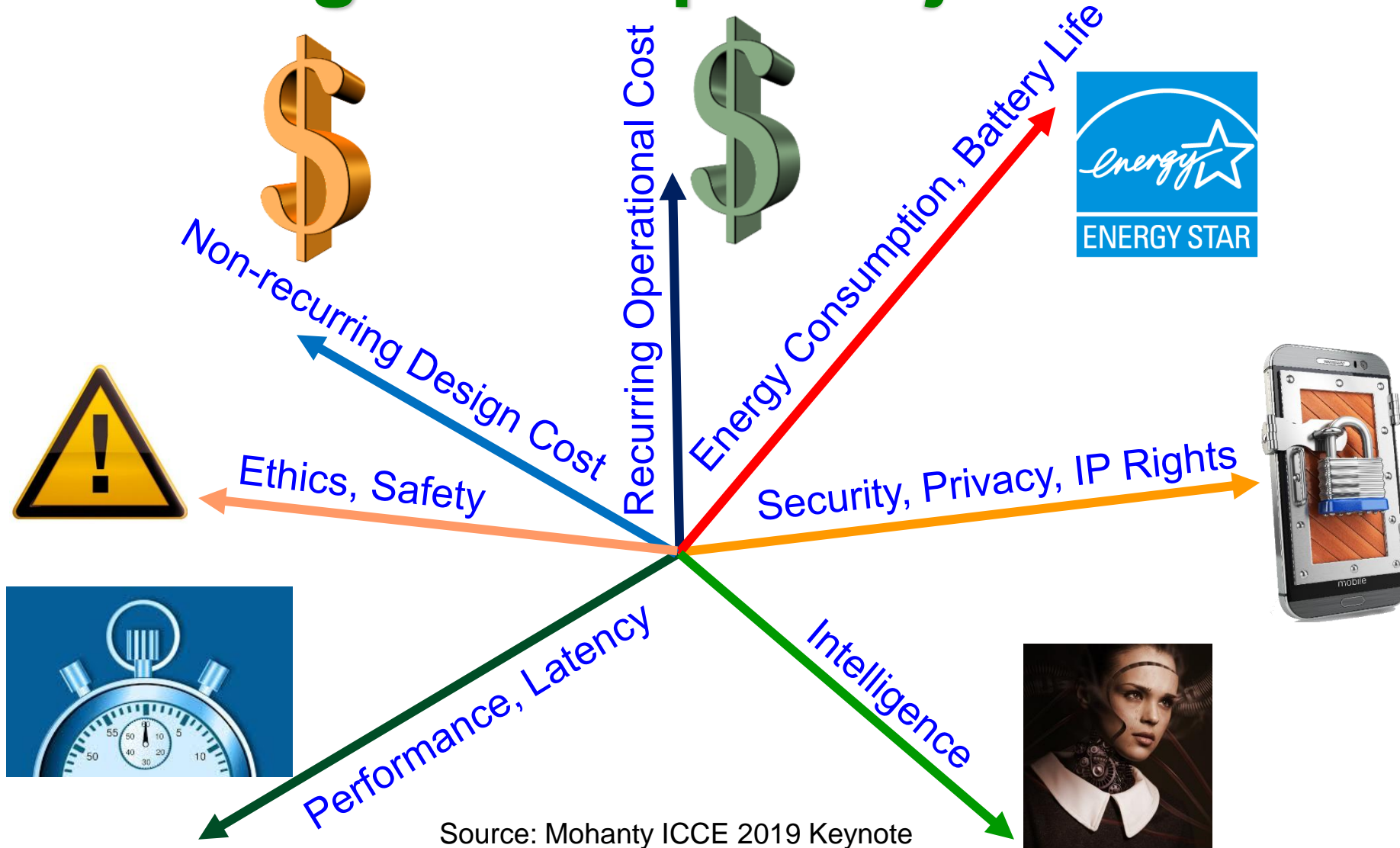

Smart Cities
Vs
Smart Villages

Source: Mohanty ICCE 2019 Keynote

Privacy by Design (PbD) → General Data Protection Regulation (GDPR)

1995

Privacy by Design (PbD)

- ❖ Treat privacy concerns as design requirements when developing technology, rather than trying to retrofit privacy controls after it is built



2018

General Data Protection Regulation (GDPR)

- ❖ GDPR makes Privacy by Design (PbD) a legal requirement

Security by Design
aka
Secure by Design (SbD)

Security by Design (SbD)

Embedding of security/privacy into the architecture (hardware+software) of various products, programs, or services.

Retrofitting: Difficult → Impossible!



Source: <https://teachprivacy.com/tag/privacy-by-design/>

Security by Design (SbD)



7 Fundamental Principles

Proactive not Reactive

Security/Privacy as the Default

Security/Privacy Embedded into Design

Full Functionality - Positive-Sum, not Zero-Sum

End-to-End Security/Privacy - Lifecycle Protection

Visibility and Transparency

Respect for Users

Source: https://iapp.org/media/pdf/resource_center/Privacy%20by%20Design%20-%207%20Foundational%20Principles.pdf

Security-by-Design (SbD) or Hardware Assisted Security (HAS) - Advantages

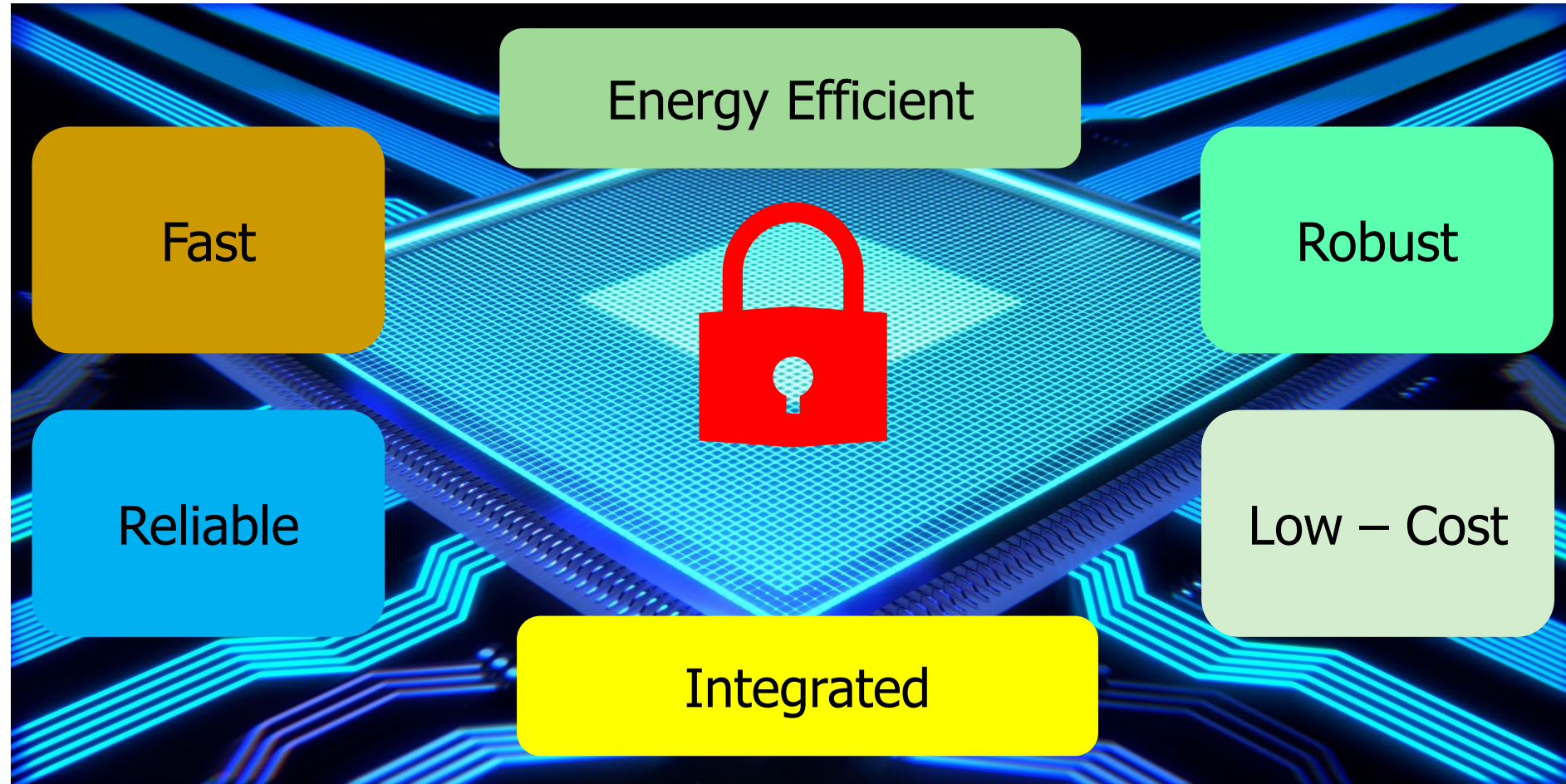

SbD Principle – IoT/CPS Design Flow

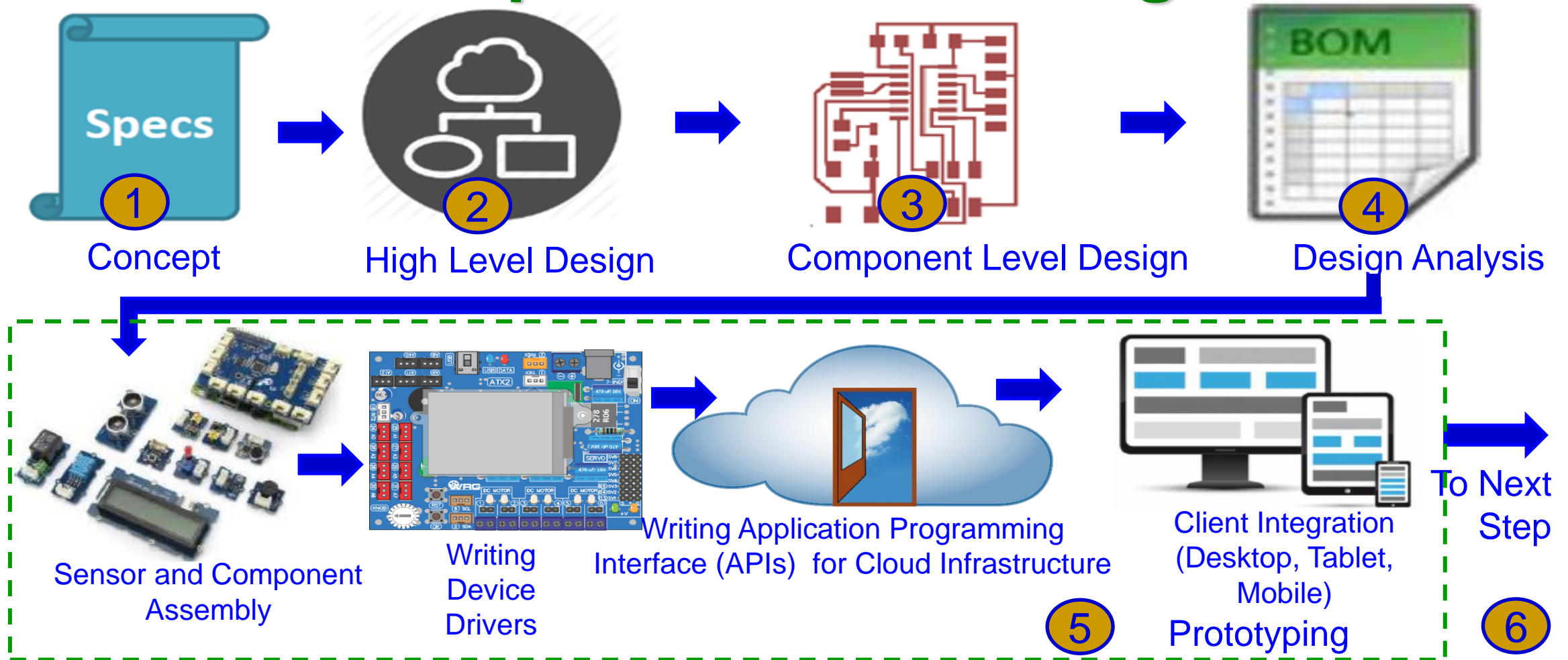

How to integrate cybersecurity and privacy at every stage of design flow?

Source: <http://events.linuxfoundation.org/sites/events/files/slides/Design%20-%20End-to-End%20%20IoT%20Solution%20-%20Shivakumar%20Mathapathi.pdf>

SbD Principle – IoT/CPS Design Flow



How to validate and document cybersecurity and privacy features at every stage of production?

Source: <http://events.linuxfoundation.org/sites/events/files/slides/Design%20-%20End-to-End%20IoT%20Solution%20-%20Shivakumar%20Mathapathi.pdf>

CPS – IoT-Edge Vs IoT-Cloud

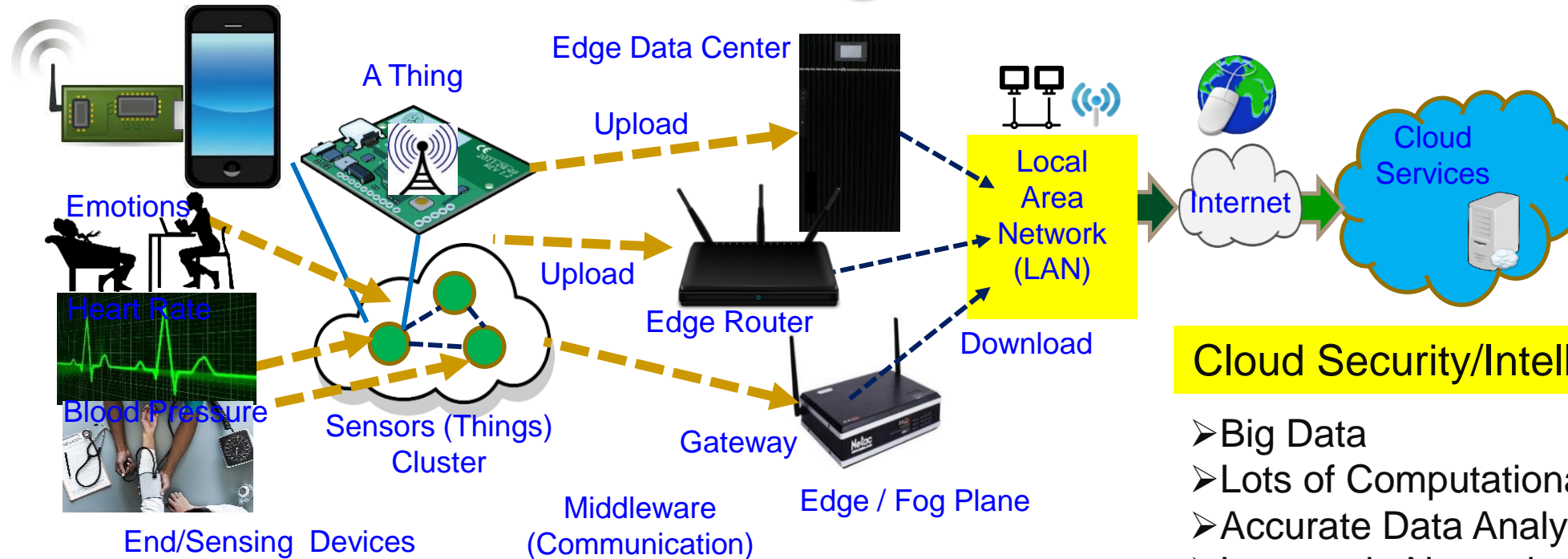

End Security/Intelligence

- Minimal Data
- Minimal Computational Resource
- Least Accurate Data Analytics
- Very Rapid Response

Edge Security/Intelligence

- Less Data
- Less Computational Resource
- Less Accurate Data Analytics
- Rapid Response

Cloud Security/Intelligence

- Big Data
- Lots of Computational Resource
- Accurate Data Analytics
- Latency in Network
- Energy Overhead in Communications

Heavy-Duty ML is more suitable for smart cities

TinyML at End and/or Edge is key for smart villages.

Hardware Cybersecurity Primitives

- HSM, TrustZone, TPM, and PUF



Hardware Security Module (HSM)

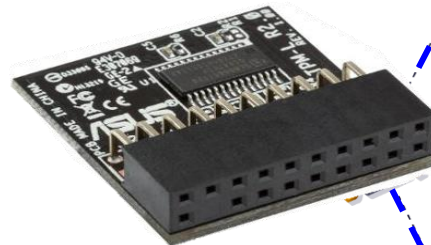

Trusted Platform Module (TPM)

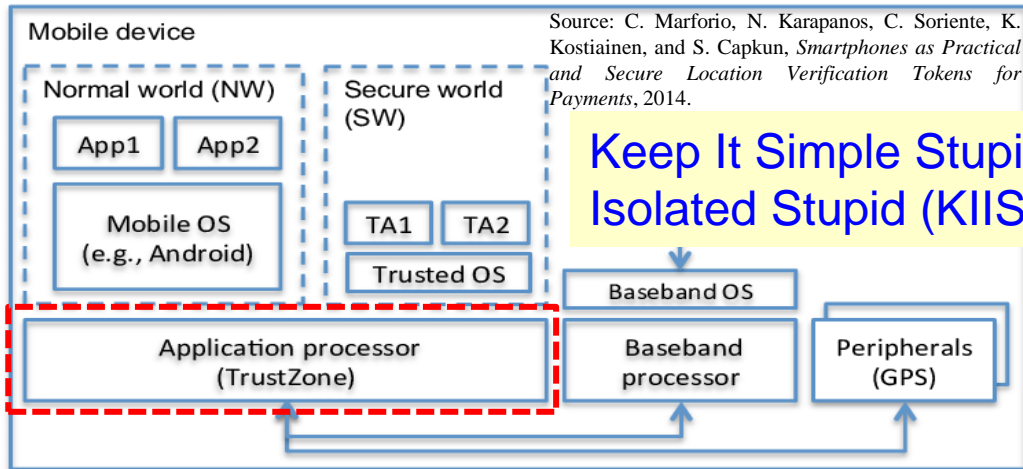
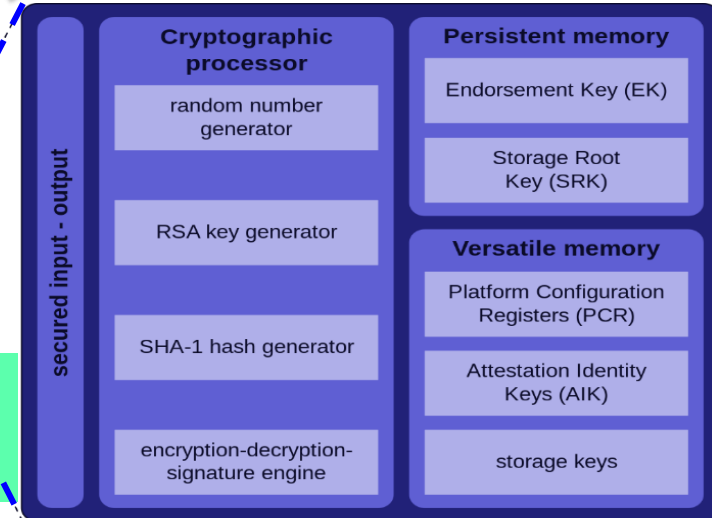

Source: C. Marforio, N. Karapanos, C. Soriente, K. Kostiainen, and S. Capkun, *Smartphones as Practical and Secure Location Verification Tokens for Payments*, 2014.

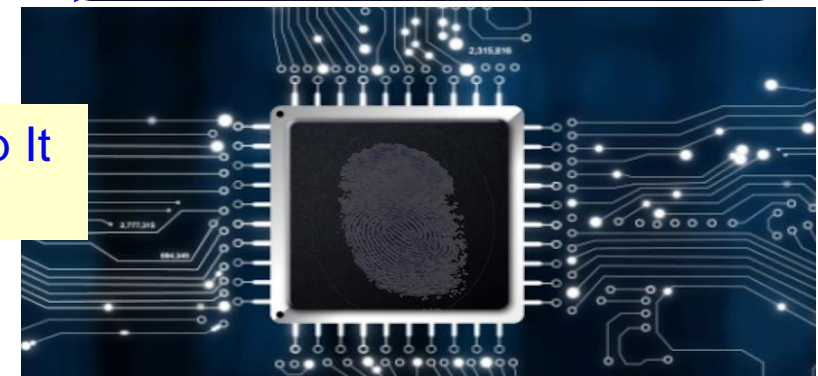

Physical Unclonable Functions (PUF)

Source: Electric Power Research Institute (EPRI)

Physical Unclonable Functions (PUF)

- Uses manufacturing variations for generating unique set of keys for cryptographic applications.
- Input of PUF is a challenge and output from PUF is response.

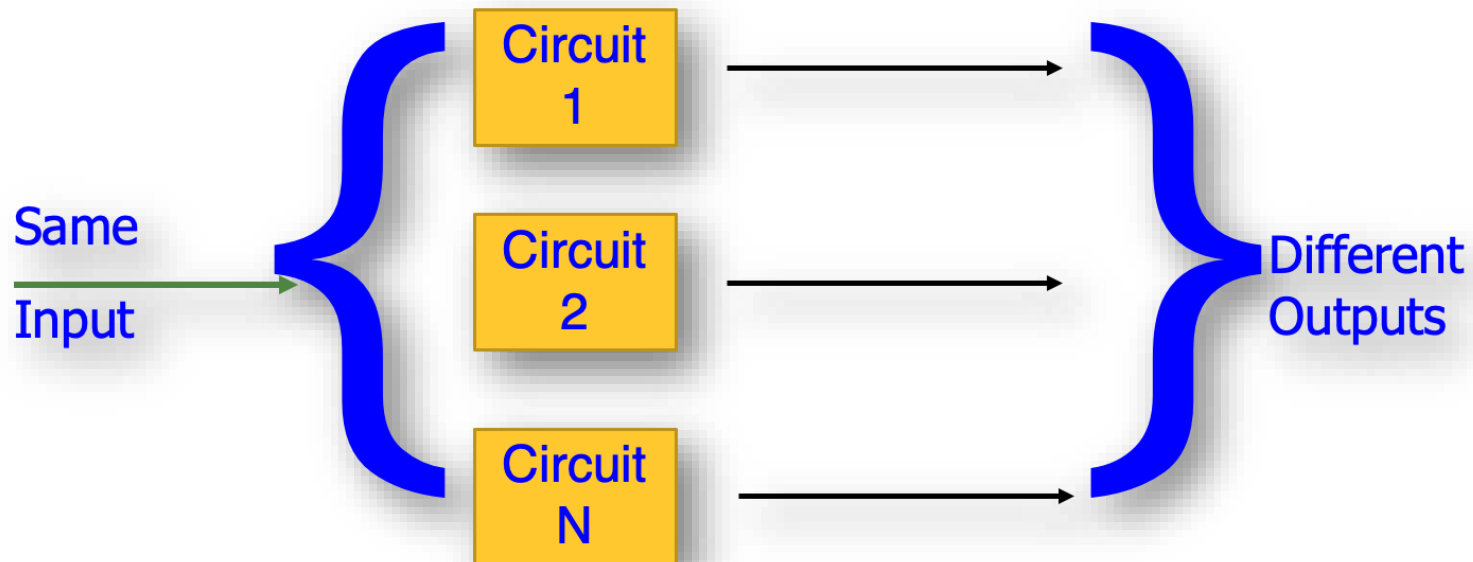

Physical Unclonable Function (PUF): Advantages

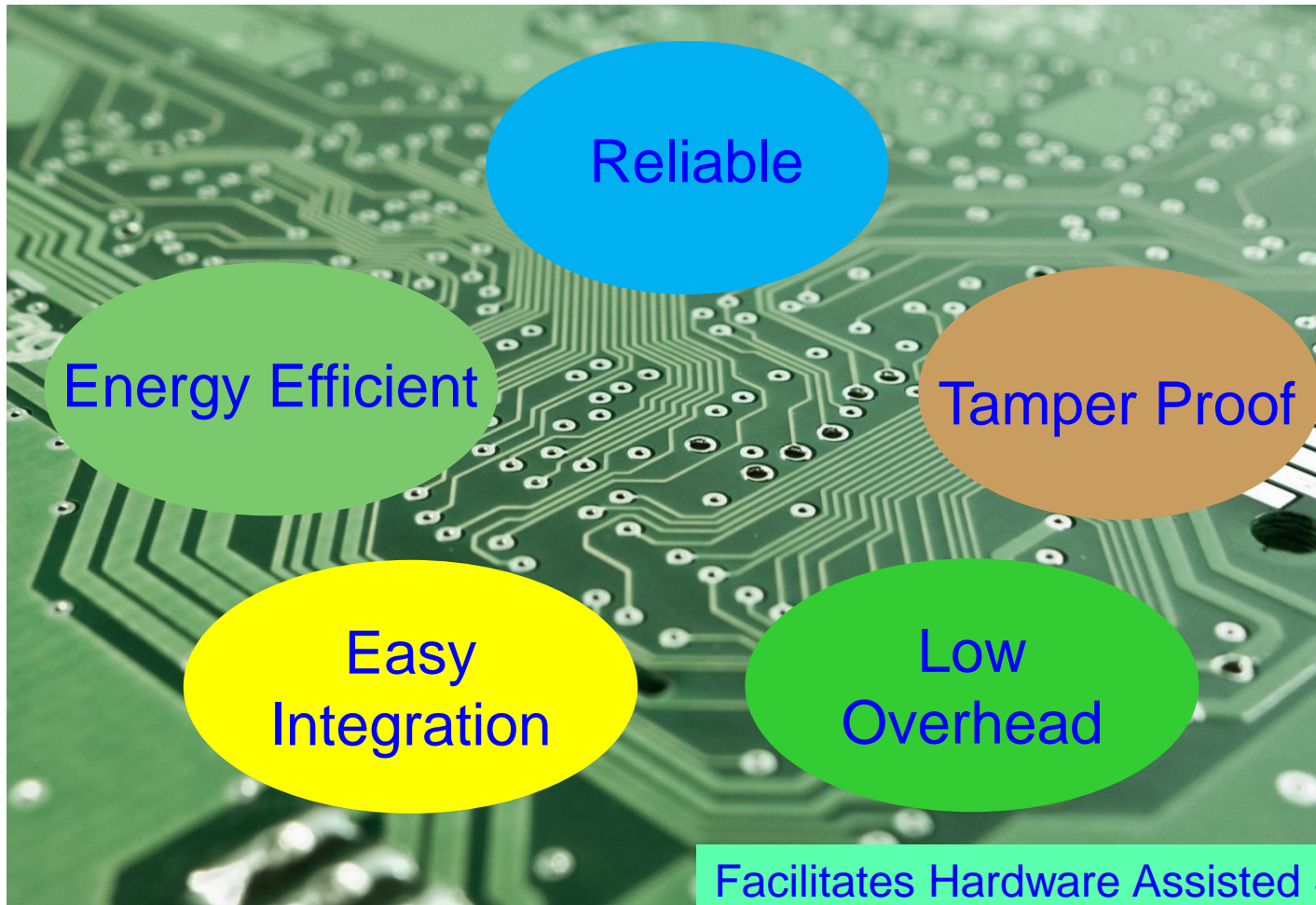

Facilitates Hardware Assisted Security (HAS) or Security-by-Design (SbD).

- A secure fingerprint generation scheme based on process variations in an Integrated Circuit
- PUFs don't store keys in digital memory, rather derive a key based on the physical characteristics of the hardware; thus secure.
- A simple design that generates cryptographically secure keys for the device authentication

PMsec: Our Secure by Design Approach for Robust Security in Healthcare CPS

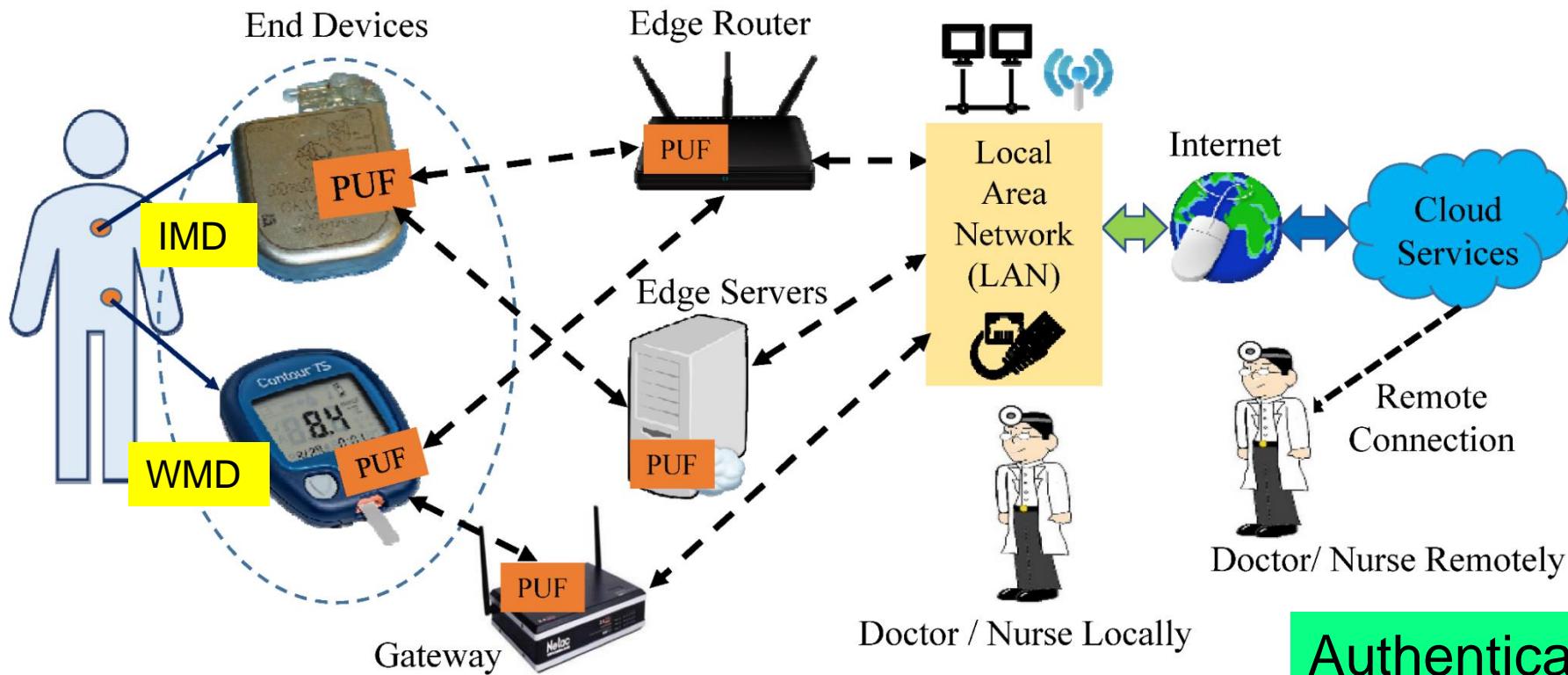

Authenticates Time - 1 sec
Power Consumption - 200 μ W

Source: V. P. Yanambaka, S. P. Mohanty, E. Kougianos, and D. Puthal, "PMsec: Physical Unclonable Function-Based Robust and Lightweight Authentication in the Internet of Medical Things", *IEEE Transactions on Consumer Electronics (TCE)*, Volume 65, Issue 3, August 2019, pp. 388--397.

IoMT Security – Our Proposed PMsec

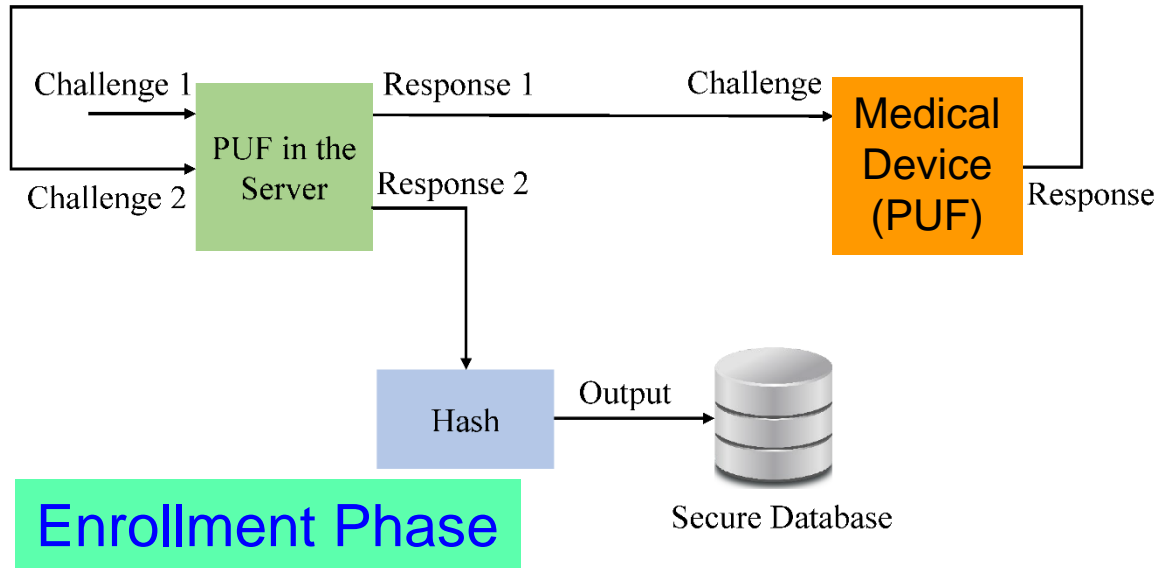

At the Doctor

- When a new IoMT-Device comes for an User

Device Registration Procedure

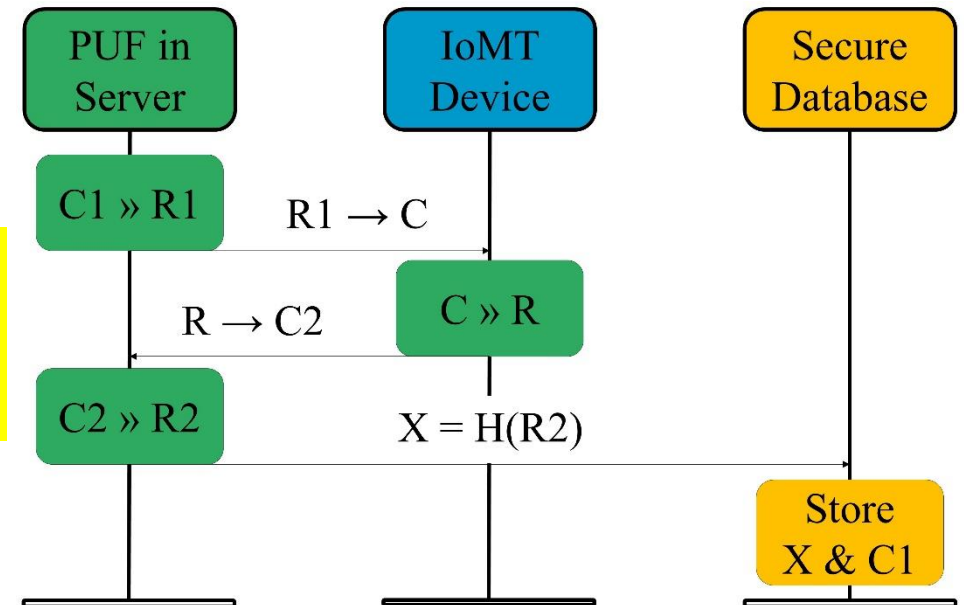

PUF Security Full Proof:

- Only server PUF Challenges are stored, not Responses
- Impossible to generate Responses without PUF

Source: V. P. Yanambaka, S. P. Mohanty, E. Kougianos, and D. Puthal, "PMsec: Physical Unclonable Function-Based Robust and Lightweight Authentication in the Internet of Medical Things", *IEEE Transactions on Consumer Electronics (TCE)*, Volume 65, Issue 3, August 2019, pp. 388--397.

IoMT Security – Our Proposed PMsec

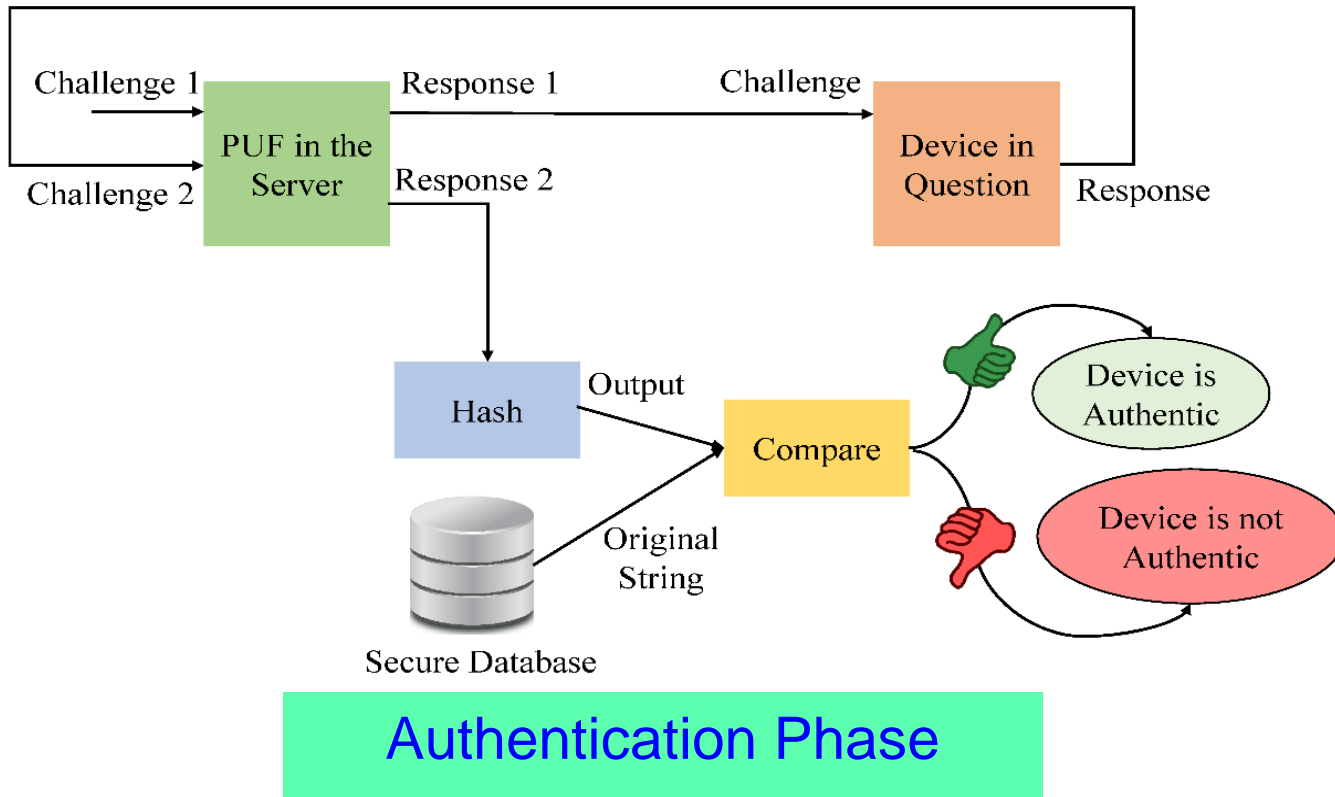

At the Doctor

➤ When doctor needs to access an existing IoMT-device

Device Authentication Procedure

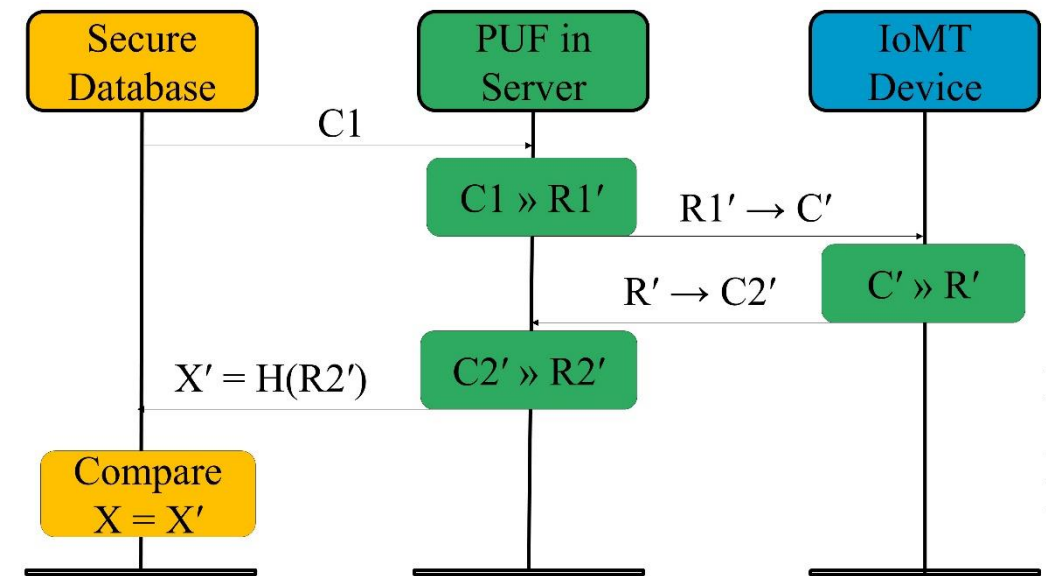

Source: V. P. Yanambaka, S. P. Mohanty, E. Kougianos, and D. Puthal, "PMsec: Physical Unclonable Function-Based Robust and Lightweight Authentication in the Internet of Medical Things", *IEEE Transactions on Consumer Electronics (TCE)*, Volume 65, Issue 3, August 2019, pp. 388--397.

Secure-iGLU - Our Intelligent Non-Invasive Glucose Monitoring with Insulin Control Device

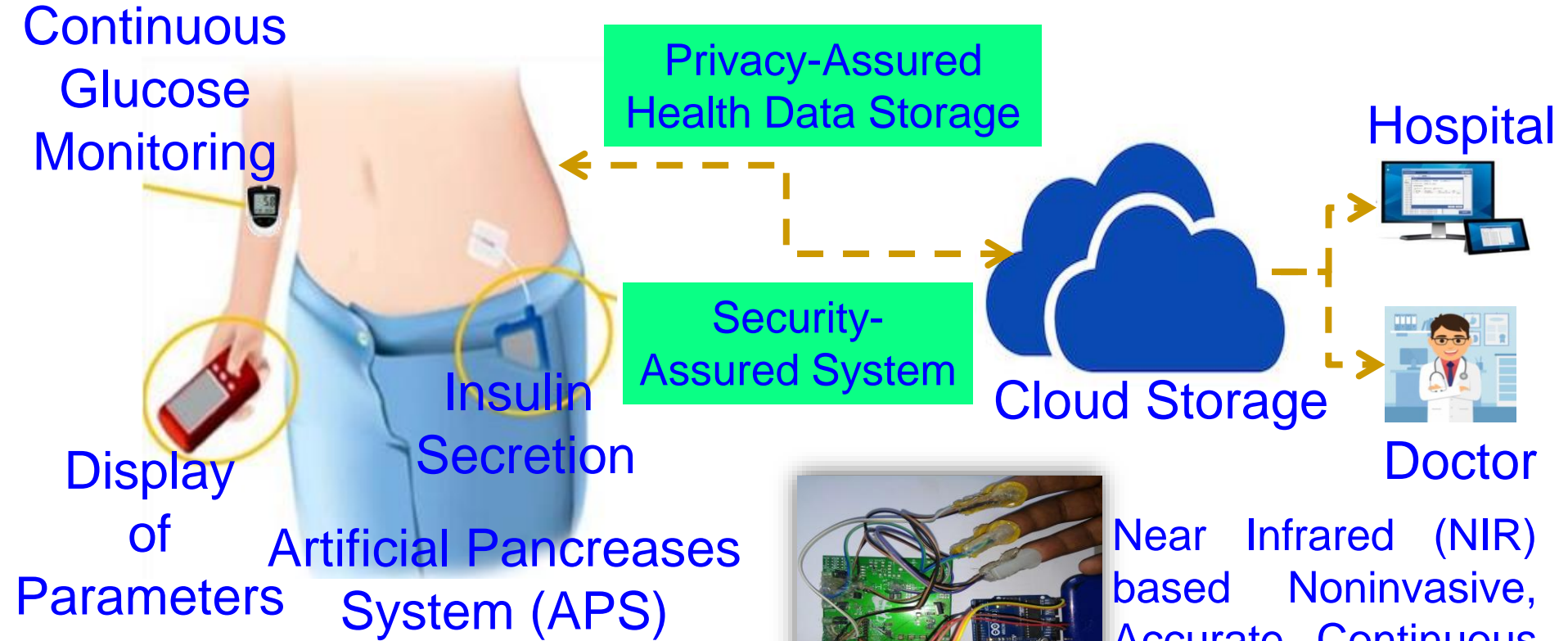

Smart Healthcare (H-CPS)
→ Security, Privacy, ...

P. Jain, A. M. Joshi, and S. P. Mohanty, "iGLU: An Intelligent Device for Accurate Non-Invasive Blood Glucose-Level Monitoring in Smart Healthcare", *IEEE Consumer Electronics Magazine (MCE)*, Vol. 9, No. 1, January 2020, pp. 35–42.

Our Smart-Yoga Pillow (SaYoPillow) with TinyML and Blockchain based Security

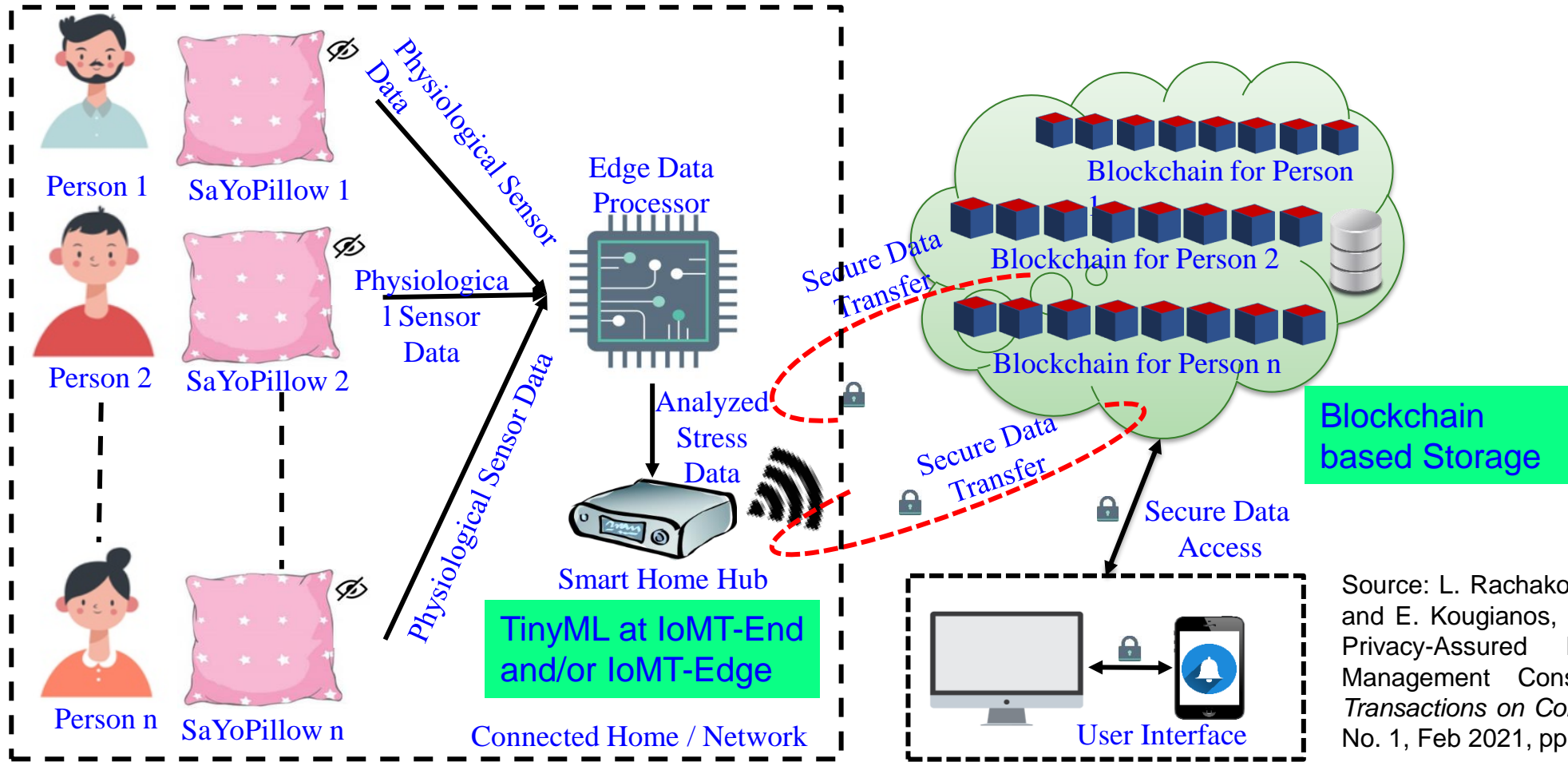

Source: L. Rachakonda, A. K. Bapatla, S. P. Mohanty, and E. Kougianos, "SaYoPillow: Blockchain-Integrated Privacy-Assured IoMT Framework for Stress Management Considering Sleeping Habit", *IEEE Transactions on Consumer Electronics (TCE)*, Vol. 67, No. 1, Feb 2021, pp. 20-29.

Our Smart Blood Alcohol Concentration Tracking Mechanism in Healthcare CPS - BACTmobile

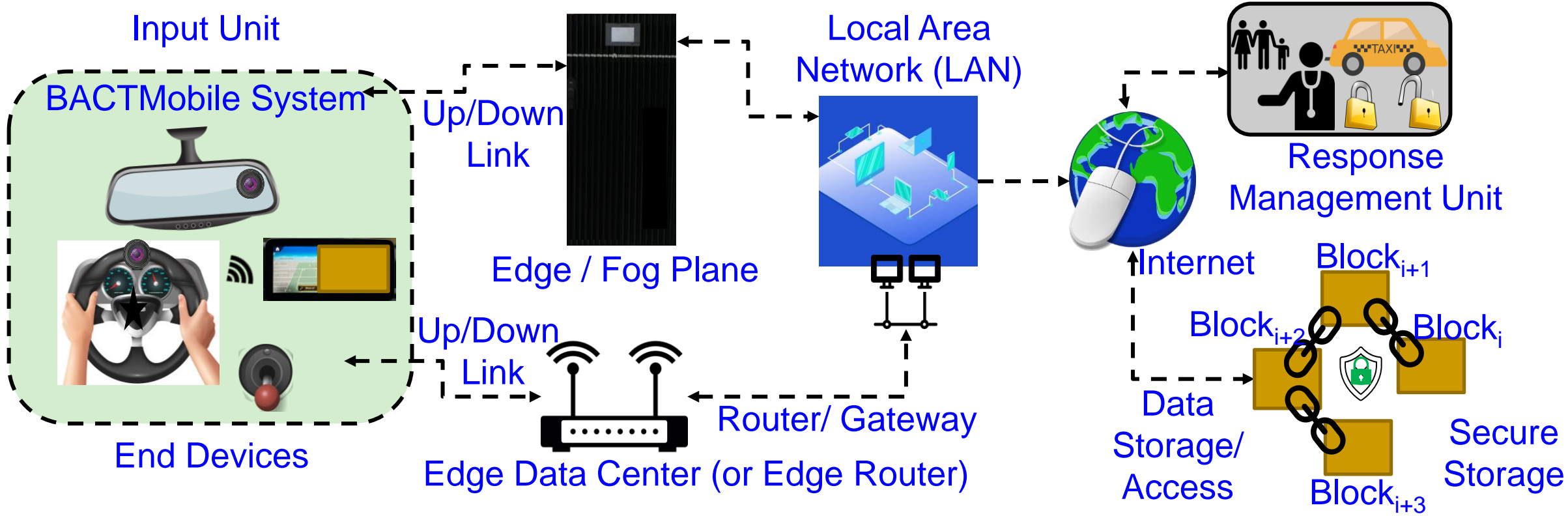

Source: L. Rachakonda, A. K. Bapatla, **S. P. Mohanty**, and E. Kougianos, "BACTmobile: A Smart Blood Alcohol Concentration Tracking Mechanism for Smart Vehicles in Healthcare CPS Framework", *Springer Nature Computer Science (SN-CS)*, Vol. 3, No. 3, May 2022, Article: 236, 24-pages, DOI: <https://doi.org/10.1007/s42979-022-01142-9>.

Our Smart Blood Alcohol Concentration Tracking Mechanism in Healthcare CPS - BACTmobile

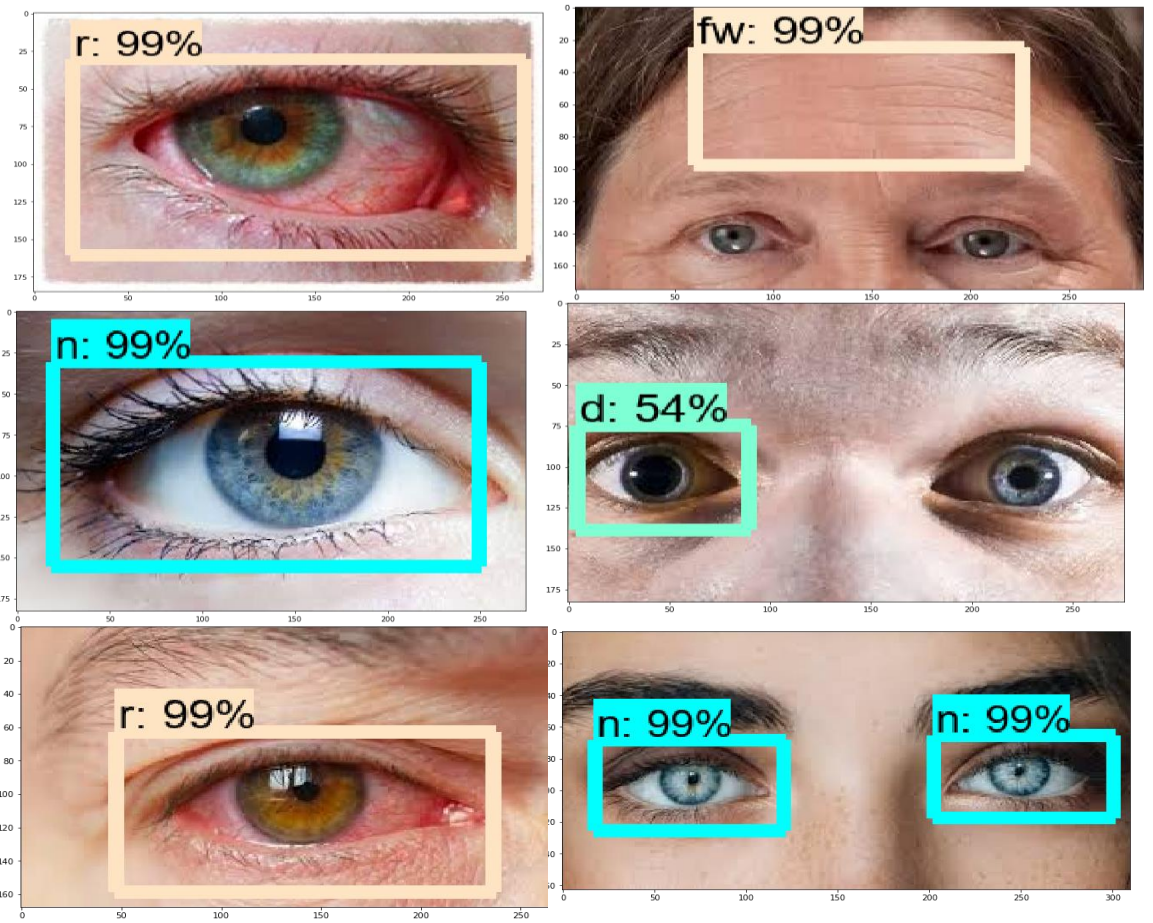
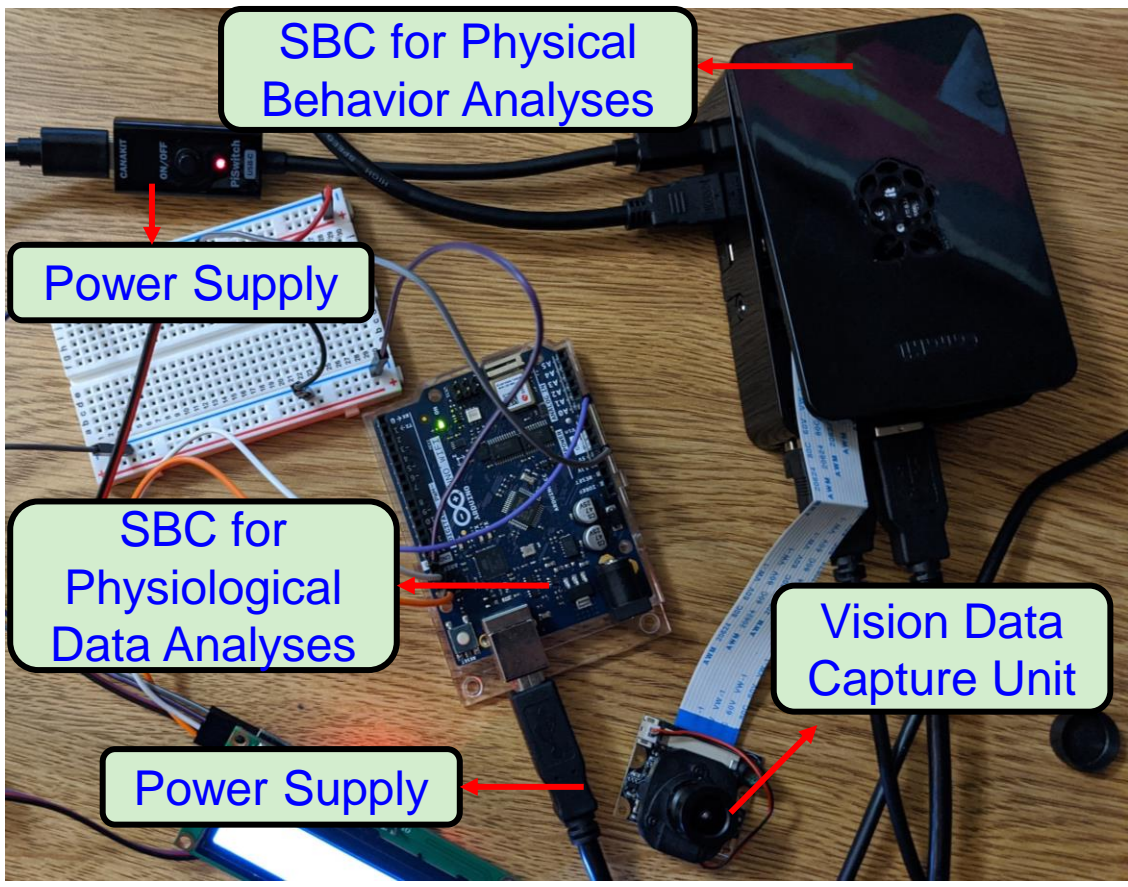

Source: L. Rachakonda, A. K. Bapatla, **S. P. Mohanty**, and E. Kougianos, "BACTmobile: A Smart Blood Alcohol Concentration Tracking Mechanism for Smart Vehicles in Healthcare CPS Framework", Springer Nature Computer Science (SN-CS), Vol. 3, No. 3, May 2022, Article: 236, 24-pages, DOI: <https://doi.org/10.1007/s42979-022-01142-9>.

IoT-Friendly Blockchain – Our EasyChain

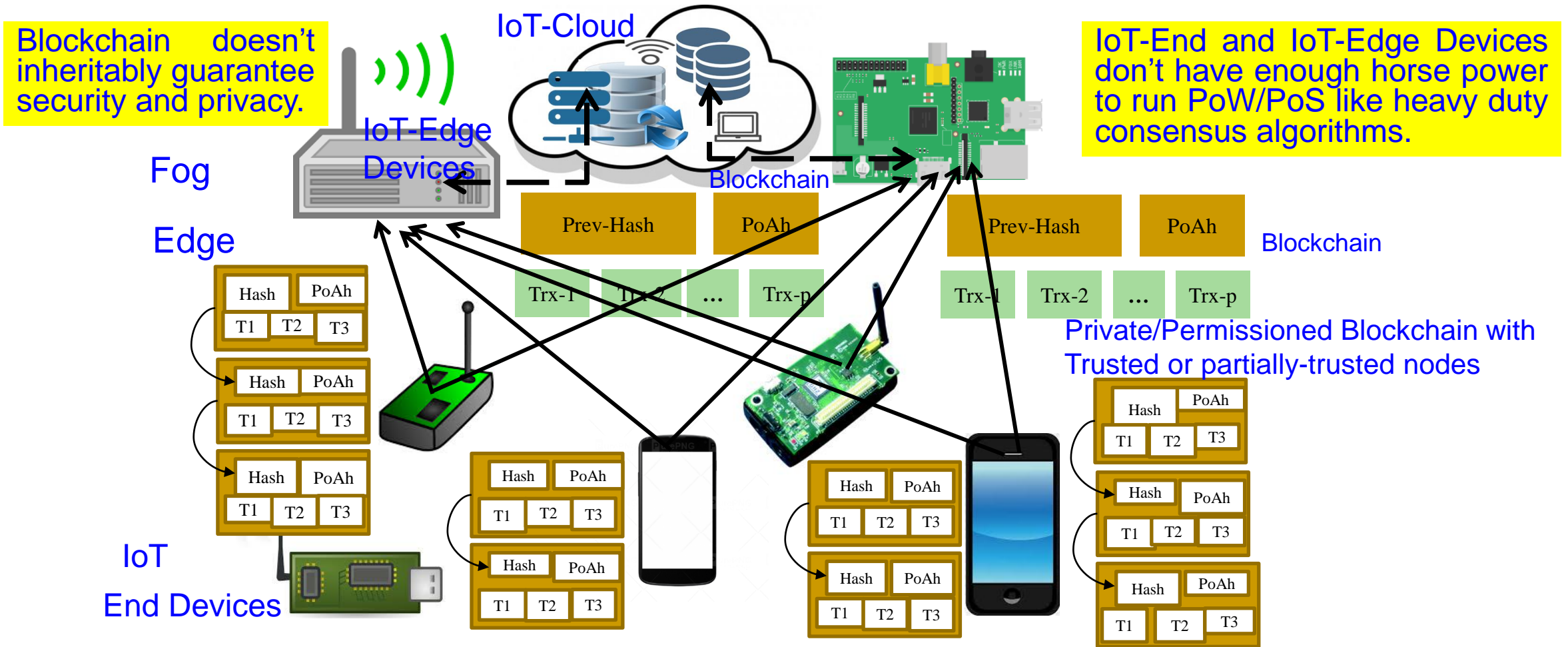

Source: D. Puthal and S. P. Mohanty, "Proof of Authentication: IoT-Friendly Blockchains", *IEEE Potentials Magazine*, Vol. 38, No. 1, January 2019, pp. 26--29.

Our EasyChain: Architectural Overview

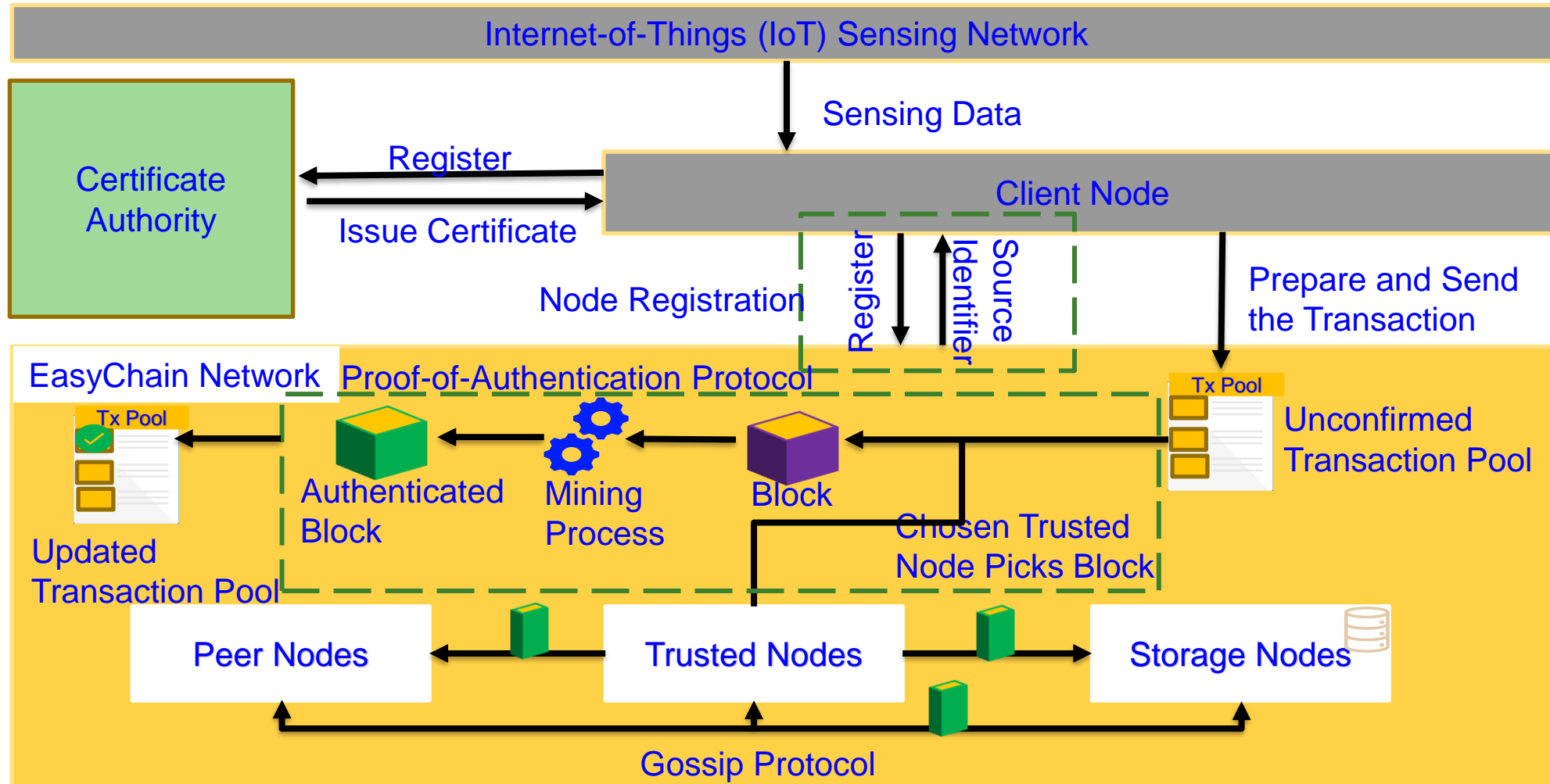

Source: A. K. Bapatla, D. Puthal, **S. P. Mohanty**, V. P. Yanambaka, and E. Kougianos, "EasyChain: An IoT-Friendly Blockchain for Robust and Energy-Efficient Authentication", *Frontiers in Blockchain*, Vol. 6, No. 1194883, Aug 2023, pp. 1--19, DOI: <https://doi.org/10.3389/fbloc.2023.1194883>.

Our EasyChain: Proof-of-Authentication (PoAh)

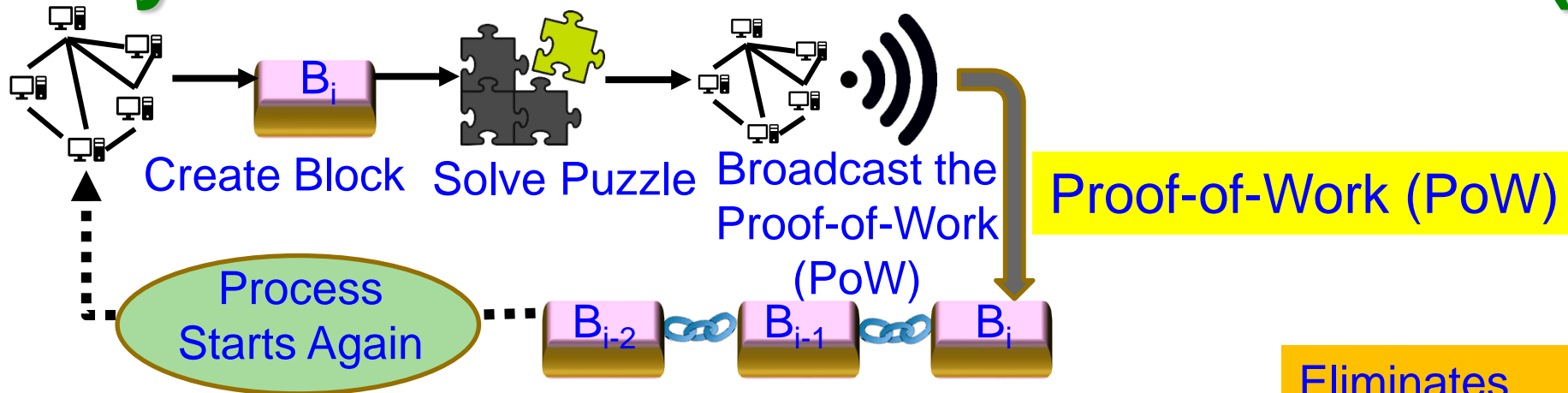

Proof of Authentication (PoAh)

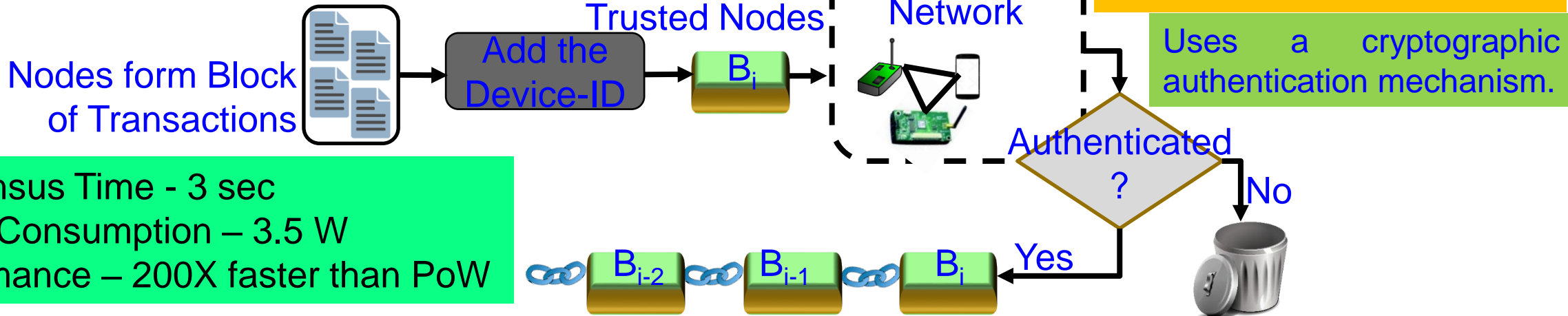

Consensus Time - 3 sec
 Power Consumption – 3.5 W
 Performance – 200X faster than PoW

Source: A. K. Bapatla, D. Puthal, **S. P. Mohanty**, V. P. Yanambaka, and E. Kougianos, "EasyChain: An IoT-Friendly Blockchain for Robust and Energy-Efficient Authentication", *Frontiers in Blockchain*, Vol. 6, No. 1194883, Aug 2023, pp. 1--19, DOI: <https://doi.org/10.3389/fbloc.2023.1194883>.

Our EasyChain with PoAh Runs in Resource Constrained Environment

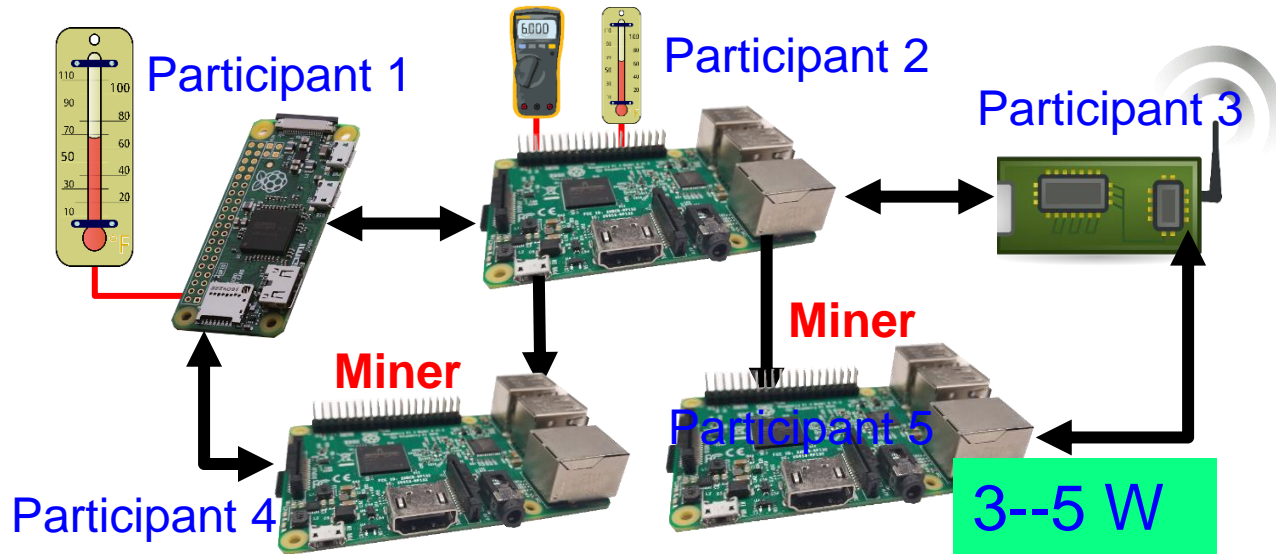

Our PoAh-Chain Runs even in IoT-end devices.

Blockchain using PoW Needs Significant Resource

500,0000 W

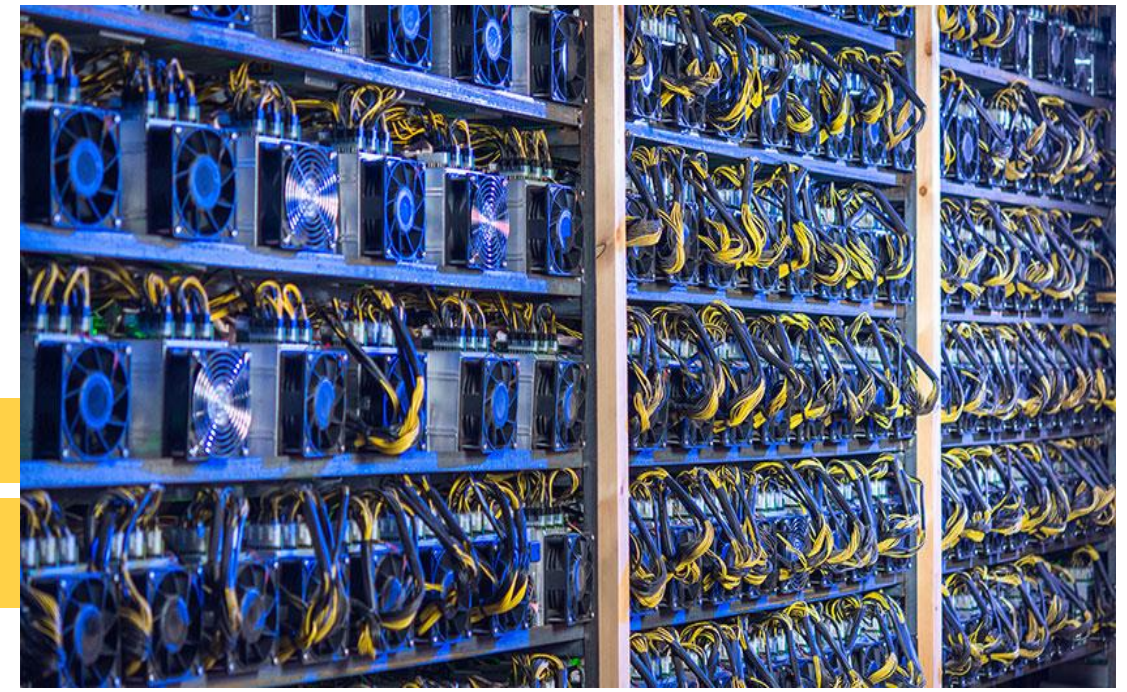

Source: <https://www.iea.org/newsroom/news/2019/july/bitcoin-energy-use-mined-the-gap.html>

Source: D. Puthal, S. P. Mohanty, V. P. Yanambaka, and E. Kougianos, "PoAh: A Novel Consensus Algorithm for Fast Scalable Private Blockchain for Large-scale IoT Frameworks", *arXiv Computer Science*, [arXiv:2001.07297](https://arxiv.org/abs/2001.07297), January 2020, 26-pages.

We Proposed World's First Hardware-Integrated Blockchain (PUFchain) that is Scalable, Energy-Efficient, and Fast

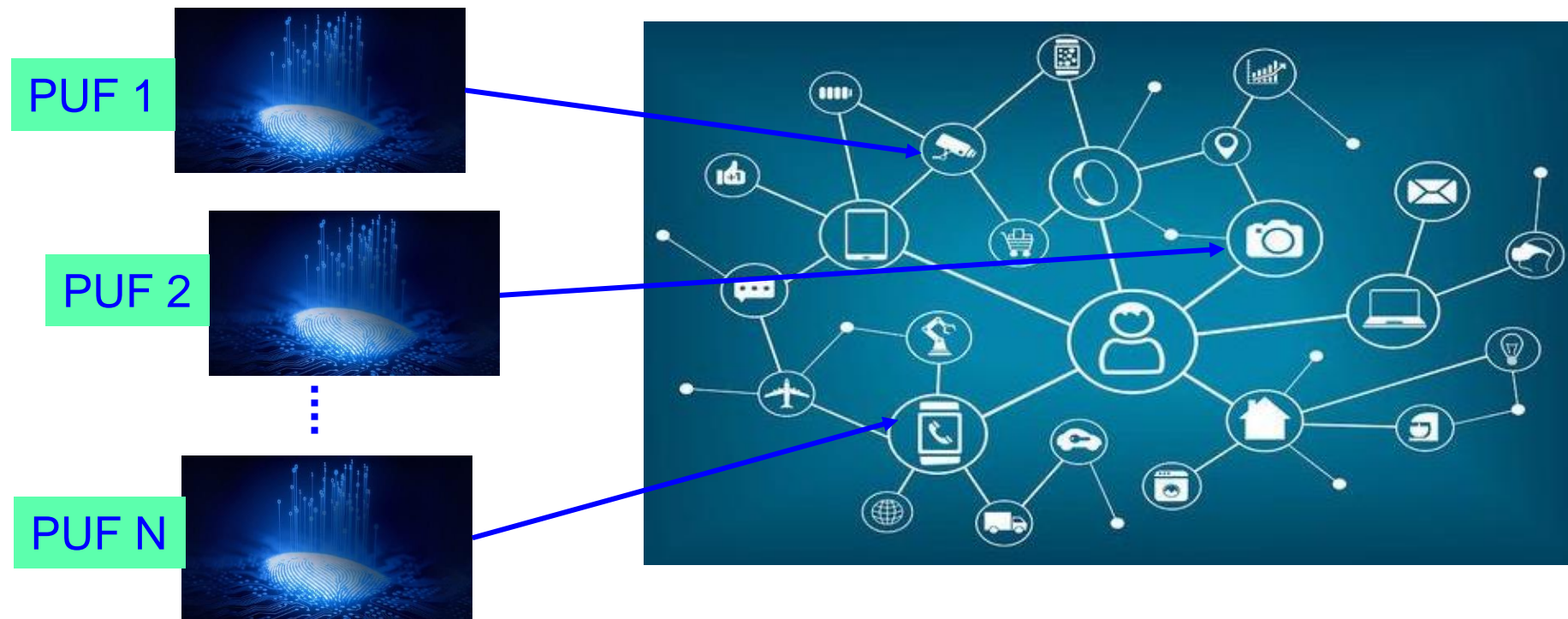

Source: S. P. Mohanty, V. P. Yanambaka, E. Kougianos, and D. Puthal, "PUFchain: Hardware-Assisted Blockchain for Sustainable Simultaneous Device and Data Security in Internet of Everything (IoE)", *IEEE Consumer Electronics Magazine (MCE)*, Vol. 9, No. 2, March 2020, pp. 8-16.

PUFchain – The Big Idea

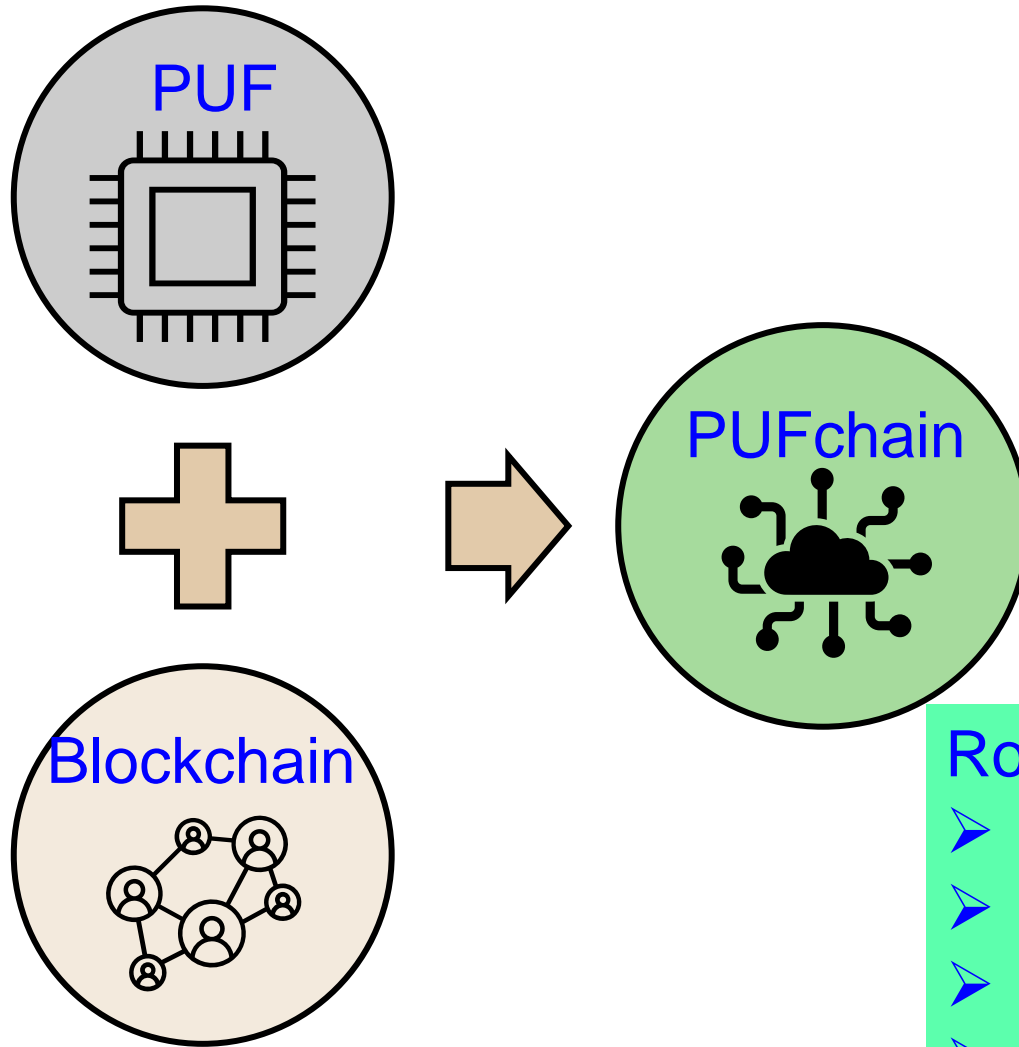

Blockchain Technology is integrated with Physically Unclonable Functions as PUFchain by storing the PUF Key into immutable Blockchain

Roles of PUF:

- Hardware Accelerator for Blockchain
- Independent Authentication
- Double-Layer Protection
- 3 modes: PUF, Blockchain, PUF+Blockchain

PUFchain: Our Hardware-Assisted Scalable Blockchain

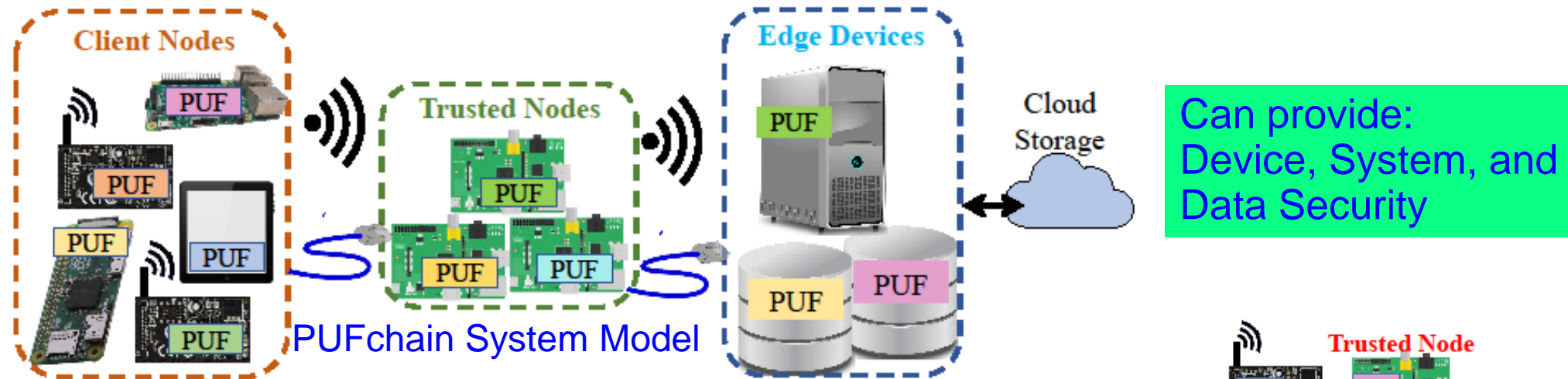

Can provide:
Device, System, and
Data Security

PUFChain 2 Modes:
(1) PUF Mode and
(2) PUFChain Mode

- ✓ PoP is 1,000X faster than PoW
- ✓ PoP is 5X faster than PoAh

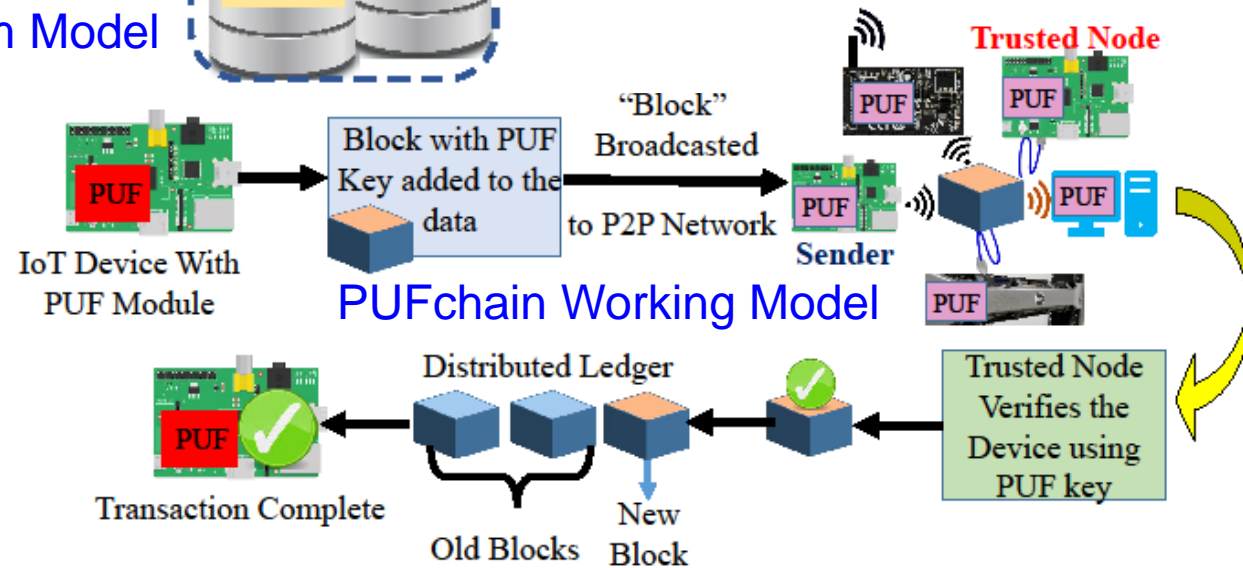

Source: S. P. Mohanty, V. P. Yanambaka, E. Kougianos, and D. Puthal, "PUFchain: Hardware-Assisted Blockchain for Sustainable Simultaneous Device and Data Security in Internet of Everything (IoE)", *IEEE Consumer Electronics Magazine (MCE)*, Vol. 9, No. 2, March 2020, pp. 8-16.

Our Proof-of-PUF-Enabled-Authentication (PoP)

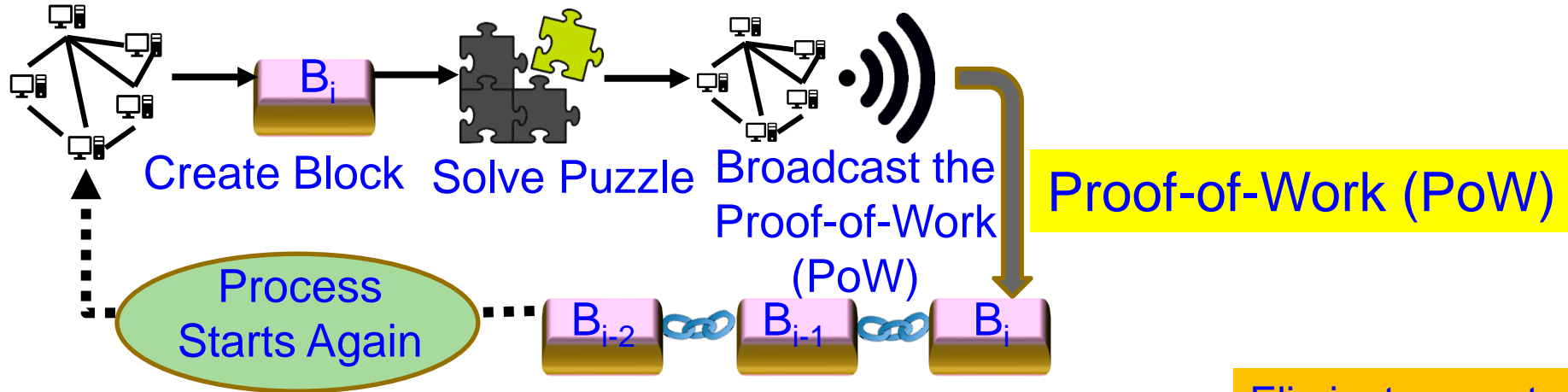

Eliminates cryptographic “puzzle” solving to validate blocks.

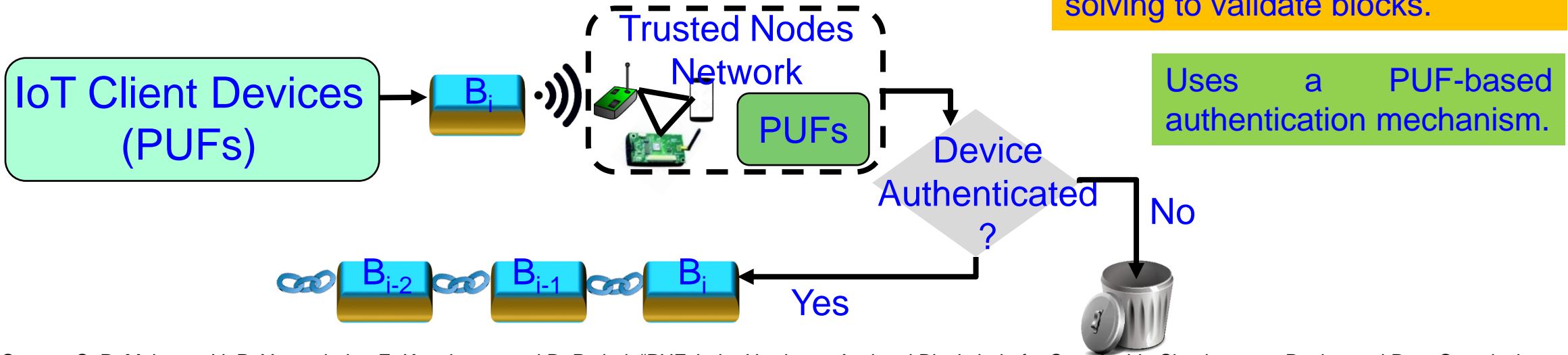

Source: S. P. Mohanty, V. P. Yanambaka, E. Kougianos, and D. Puthal, “PUFchain: Hardware-Assisted Blockchain for Sustainable Simultaneous Device and Data Security in Internet of Everything (IoE)”, *IEEE Consumer Electronics Magazine (MCE)*, Vol. 9, No. 2, March 2020, pp. 8-16.

PUFchain: Our PoP is 1000X Faster than PoW

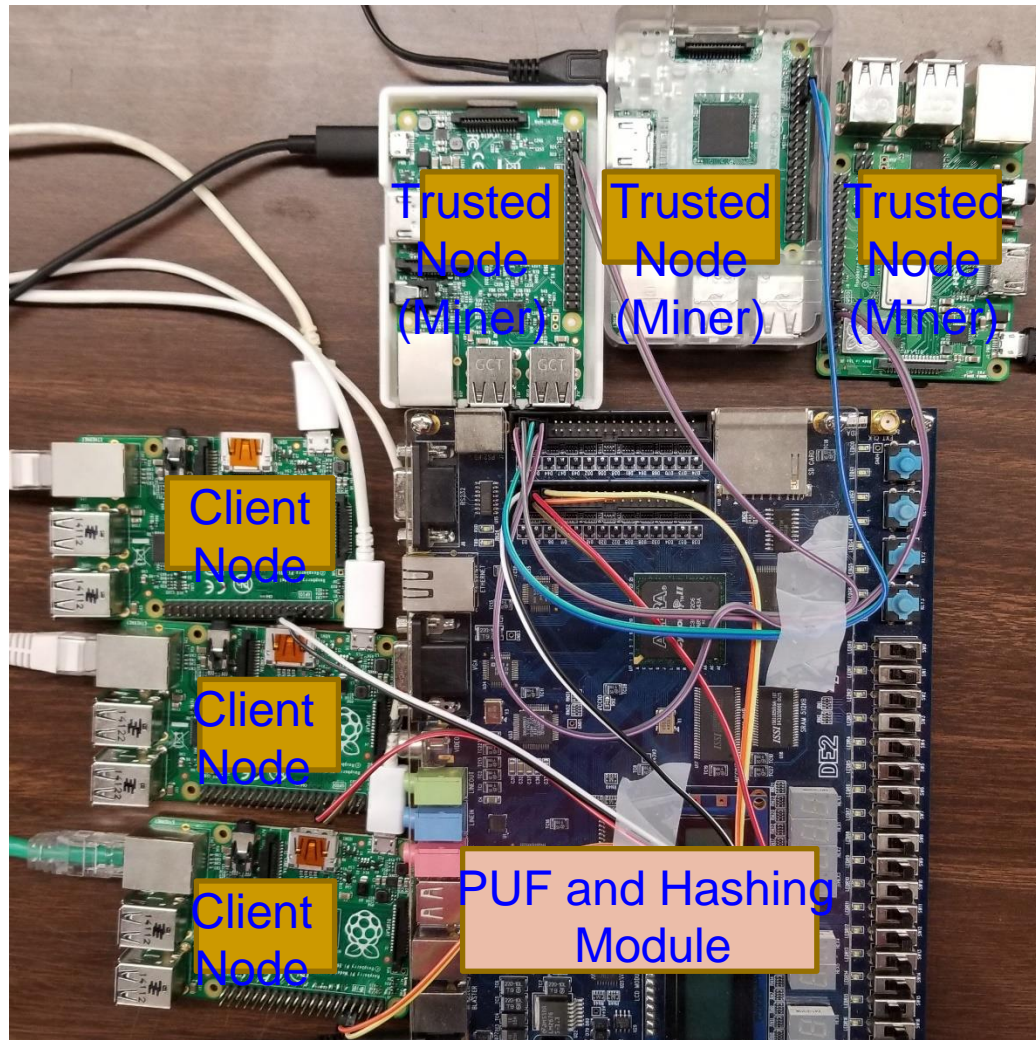

PoW - 10
min in cloud

PoAh – 950ms
in Raspberry Pi

PoP - 192ms
in Raspberry Pi

High Power

3 W Power

5 W Power

- ✓ PoP is 1,000X faster than PoW
- ✓ PoP is 5X faster than PoAh

Source: S. P. Mohanty, V. P. Yanambaka, E. Kougianos, and D. Puthal, "PUFchain: Hardware-Assisted Blockchain for Sustainable Simultaneous Device and Data Security in Internet of Everything (IoE)", *IEEE Consumer Electronics Magazine (MCE)*, Vol. 9, No. 2, March 2020, pp. 8-16.

PUFchain 2.0: Our Hardware-Assisted Scalable Blockchain

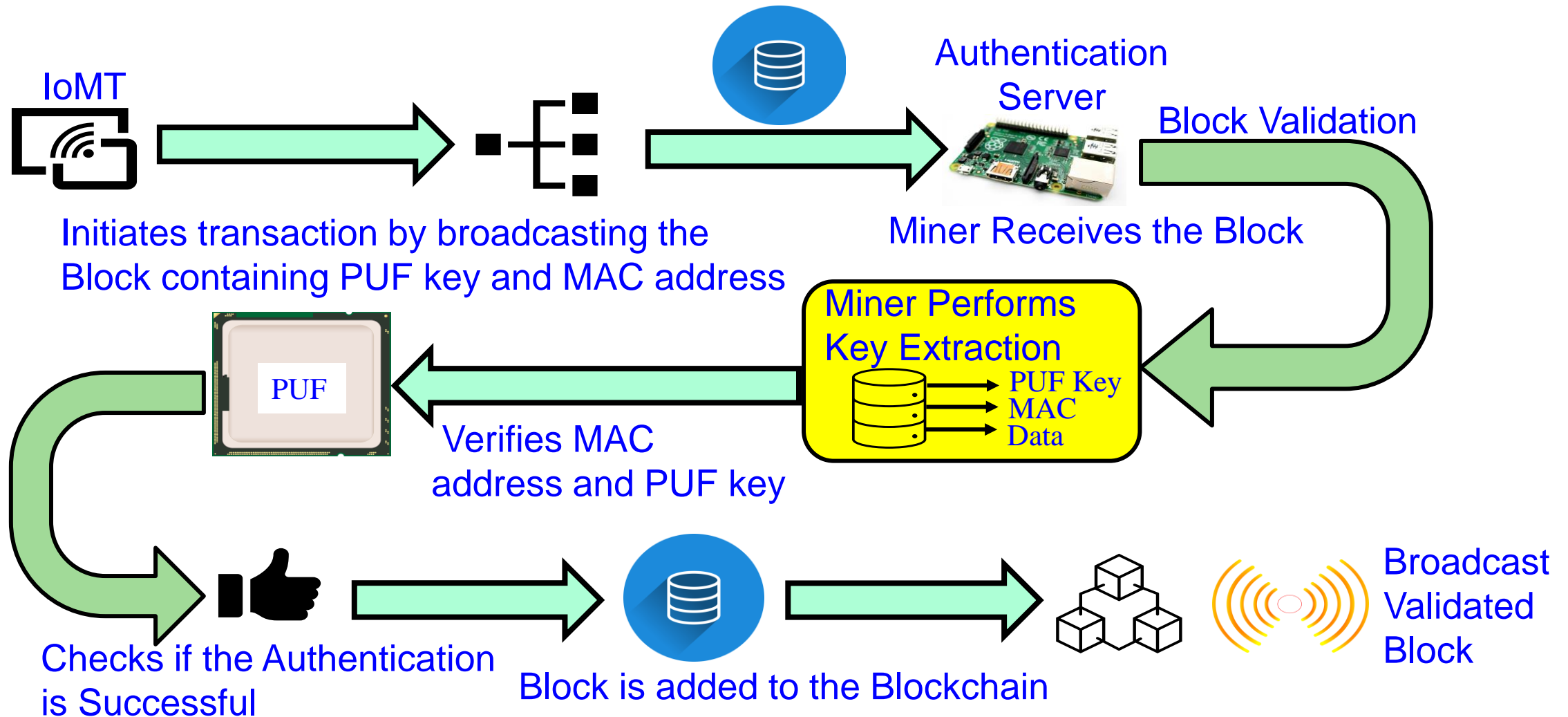

Source: V. K. V. V. Bathalapalli, **S. P. Mohanty**, E. Kougianos, B. K. Baniya, and B. Rout, "PUFchain 2.0: Hardware-Assisted Robust Blockchain for Sustainable Simultaneous Device and Data Security in Smart Healthcare", *Springer Nature Computer Science (SN-CS)*, Vol. 3, No. 5, Sep 2022, Article: 344, 19-pages, DOI: <https://doi.org/10.1007/s42979-022-01238-2>.

PUFchain 2.0: PUF Integrated Blockchain ...

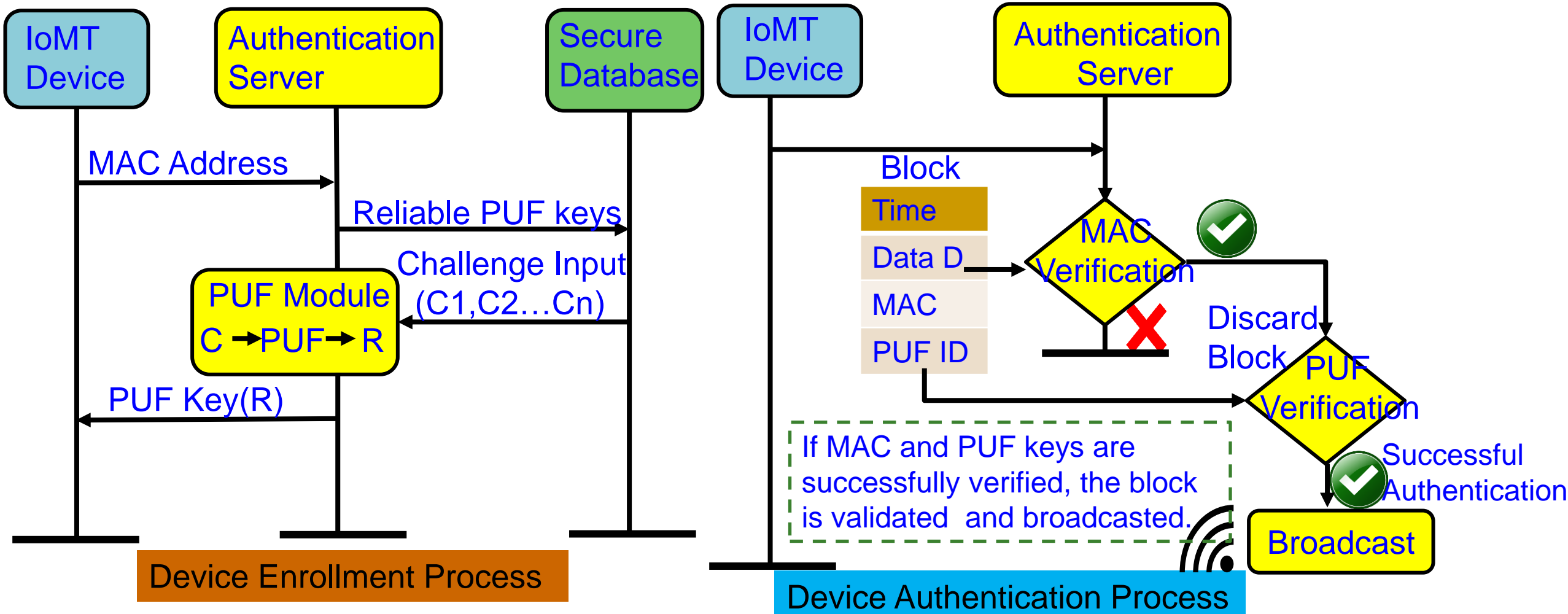

Source: V. K. V. V. Bathalapalli, **S. P. Mohanty**, E. Kougianos, B. K. Baniya, and B. Rout, "PUFchain 2.0: Hardware-Assisted Robust Blockchain for Sustainable Simultaneous Device and Data Security in Smart Healthcare", *Springer Nature Computer Science (SN-CS)*, Vol. 3, No. 5, Sep 2022, Article: 344, 19-pages, DOI: <https://doi.org/10.1007/s42979-022-01238-2>.

PUFchain 3.0 - Conceptual Idea

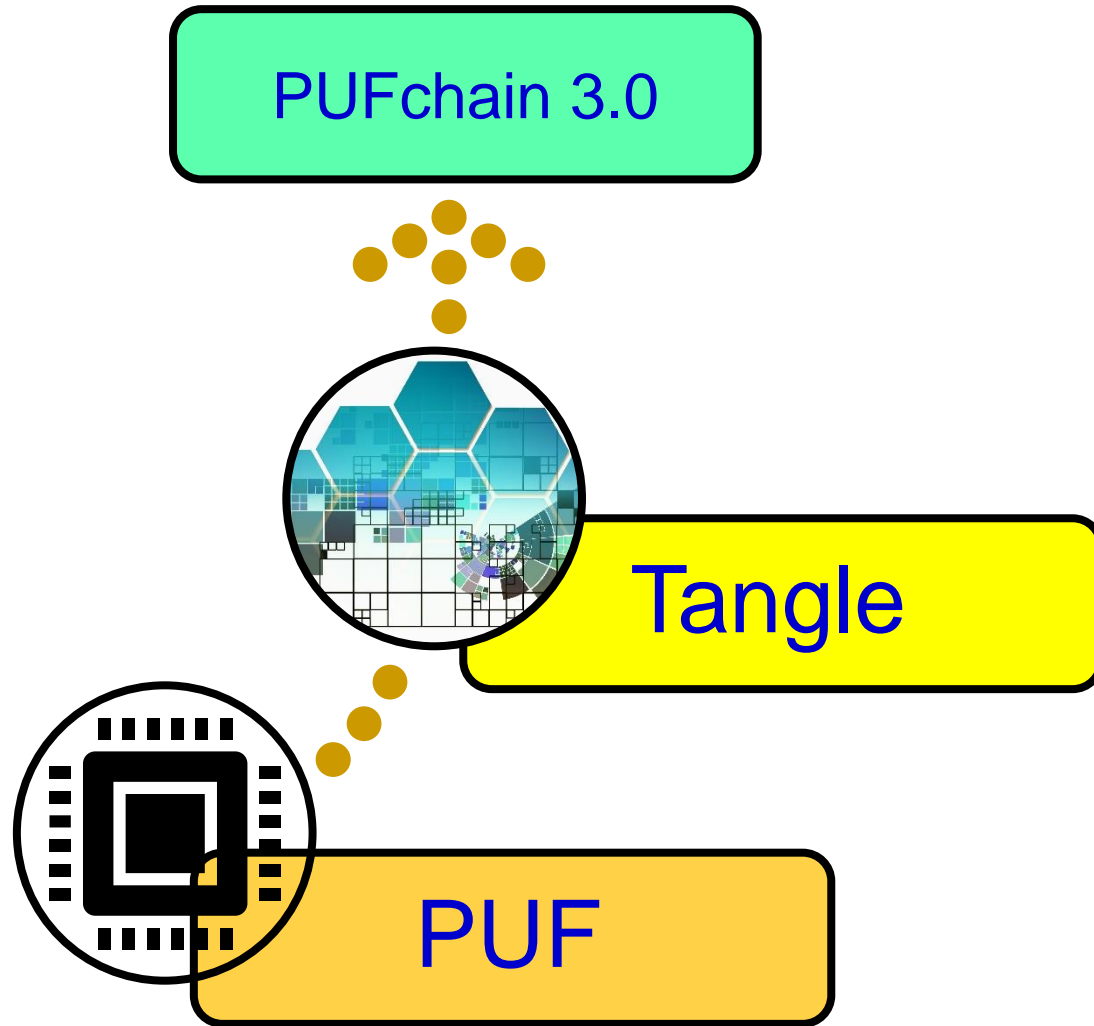

- PUFchain 3.0 is the idea of integrating PUF with scalable Tangle DLT using MAM communication protocol by creating a MAM communication channel in Tangle using PUF key

Source: V. K. V. V. Bathalapalli, **S. P. Mohanty**, E. Kougianos, B. K. Baniya, and B. Rout, "PUFchain 3.0: Hardware-Assisted Distributed Ledger for Robust Authentication in the Internet of Medical Things", in *Proceedings of IFIP International Internet of Things Conference (IFIP-IoT)*, 2022, pp. 23--40, DOI: https://doi.org/10.1007/978-3-031-18872-5_2.

PUFchain 3.0 - Architecture

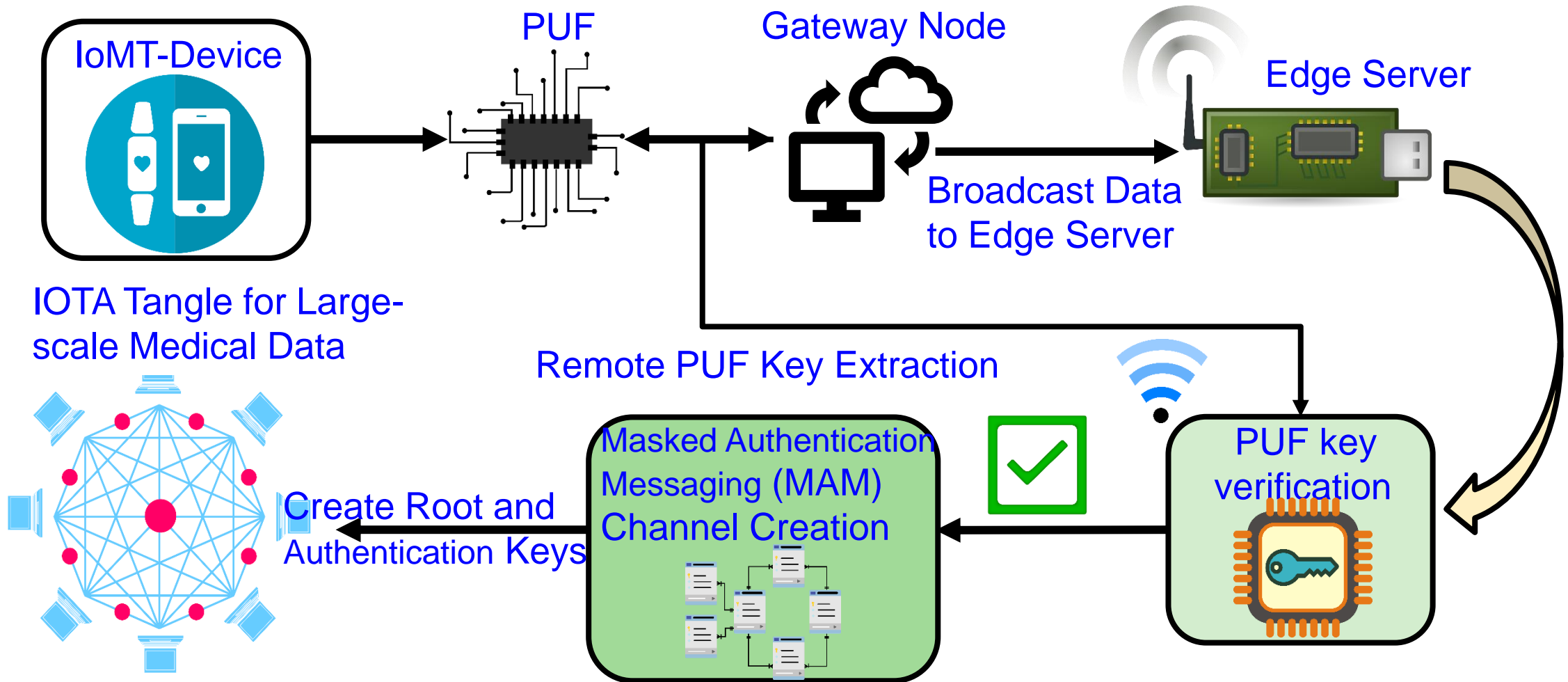

Source: V. K. V. V. Bathalapalli, **S. P. Mohanty**, E. Kougianos, B. K. Baniya, and B. Rout, "PUFchain 3.0: Hardware-Assisted Distributed Ledger for Robust Authentication in the Internet of Medical Things", in *Proceedings of IFIP International Internet of Things Conference (IFIP-IoT)*, 2022, pp. 23--40, DOI: https://doi.org/10.1007/978-3-031-18872-5_2.

PUFchain 3.0: Comparative Analysis

| Research Works | Application | DLT or Blockchain | Authentication Mechanism | Performance Metrics |
|--|------------------------|---------------------|---|--|
| Mohanty et al. 2020 - PUFchain | IoMT (Device and Data) | Blockchain | Proof-of-PUF-Enabled Authentication | PUF Design Uniqueness - 47.02%, Reliability-1.25% |
| Chaudhary et al. 2021 - Auto-PUFchain | Hawrdware Supply Chain | Blockchain | Smart Contracts | Gas Cost for Ethereum transaction 21.56 USD (5-Stage) |
| Al-Joboury et al. 2021 - PoQDB | IoT (Data) | Blockchain & Cobweb | IoT M2M Messaging (MQTT) | Transaction Time - 15 ms |
| Wang et al. 2022 - PUF-Based Authentication | IoMT (Device) | Blockchain | Smart Contracts | NA |
| Hellani et al. 2021- Tangle the Blockchain | IoT (Data) | Blockchain & Tangle | Smart Contracts | NA |
| Bathalapalli et al. 2022-PUFchain 2.0 | IoMT (Device) | Blockchain | Media Access Control (MAC) & PUF based Authentication | Total On-Chip Power - 0.081 W, PUF Hamming Distance - 48.02 % |
| Our PUFchain 3.0 in 2022 | IoMT (Device) | Tangle | Masked Authentication Messaging | Authentication 2.72 sec, Reliability - 100% (Approx), MAM Mode-Restricted |

Source: V. K. V. V. Bathalapalli, **S. P. Mohanty**, E. Kougianos, B. K. Baniya, and B. Rout, “[PUFchain 3.0: Hardware-Assisted Distributed Ledger for Robust Authentication in the Internet of Medical Things](https://doi.org/10.1007/978-3-031-18872-5_2)”, in *Proceedings of IFIP International Internet of Things Conference (IFIP-IoT)*, 2022, pp. 23--40, DOI: https://doi.org/10.1007/978-3-031-18872-5_2.

Smart Healthcare – Trustworthy Pharmaceutical Supply Chain

Counterfeits in Healthcare



The original product:

- sold in a white box with blue borders
- contains sixty (60) 500mg tablets
- divided on four (4) silver blister packs, each containing fifteen (15) tablets

The fake product:

- sold in a white box with no border
- contains sixty (60) 500mg tablets
- divided on six (6) silver with blue blister packs, each containing ten (10) tablets

Source: GA-FDD (Government Analyst – Food and Drug Department) issues warning over “fake” drug on local market,
<https://www.inewsguyana.com/ga-fdd-issues-warning-over-fake-drug-on-local-market/>

Daflon 500 is used to treat gravitational (stasis) dermatitis and dermatofibrosclerosis

Counterfeits in Healthcare



- Drug Components: Active Pharmaceutical Ingredient (API) + Excipients or inactive ingredients
- Counterfeit Drugs: Less API or no API or wrong API drugs produced in sub-standard conditions

Source: GA-FDD's (Government Analyst –Food and Drug Department's) occasional fake drugs disclosures may be tip of the iceberg, <https://www.stabroeknews.com/2019/09/06/business/ga-fdds-occasional-fake-drugs-disclosures-may-be-tip-of-the-iceberg/>

Fake Medicine - Serious Global Issue

- It is estimated that close to \$83 billion worth of counterfeit drugs are sold annually.
- One in 10 medical products circulating in developing countries are substandard or fake.
- In Africa: Counterfeit antimalarial drugs results in more than 120,000 deaths each year.
- USA has a closed drug distribution system intended to prevent counterfeits from entering U.S. markets, but it isn't foolproof due to many reason including illegal online pharmacy.

Source: <https://fraud.org/fakerx/fake-drugs-and-their-risks/counterfeit-drugs-are-a-global-problem/>



Source: <https://allaboutpharmacovigilance.org/be-aware-of-counterfeit-medicine/>

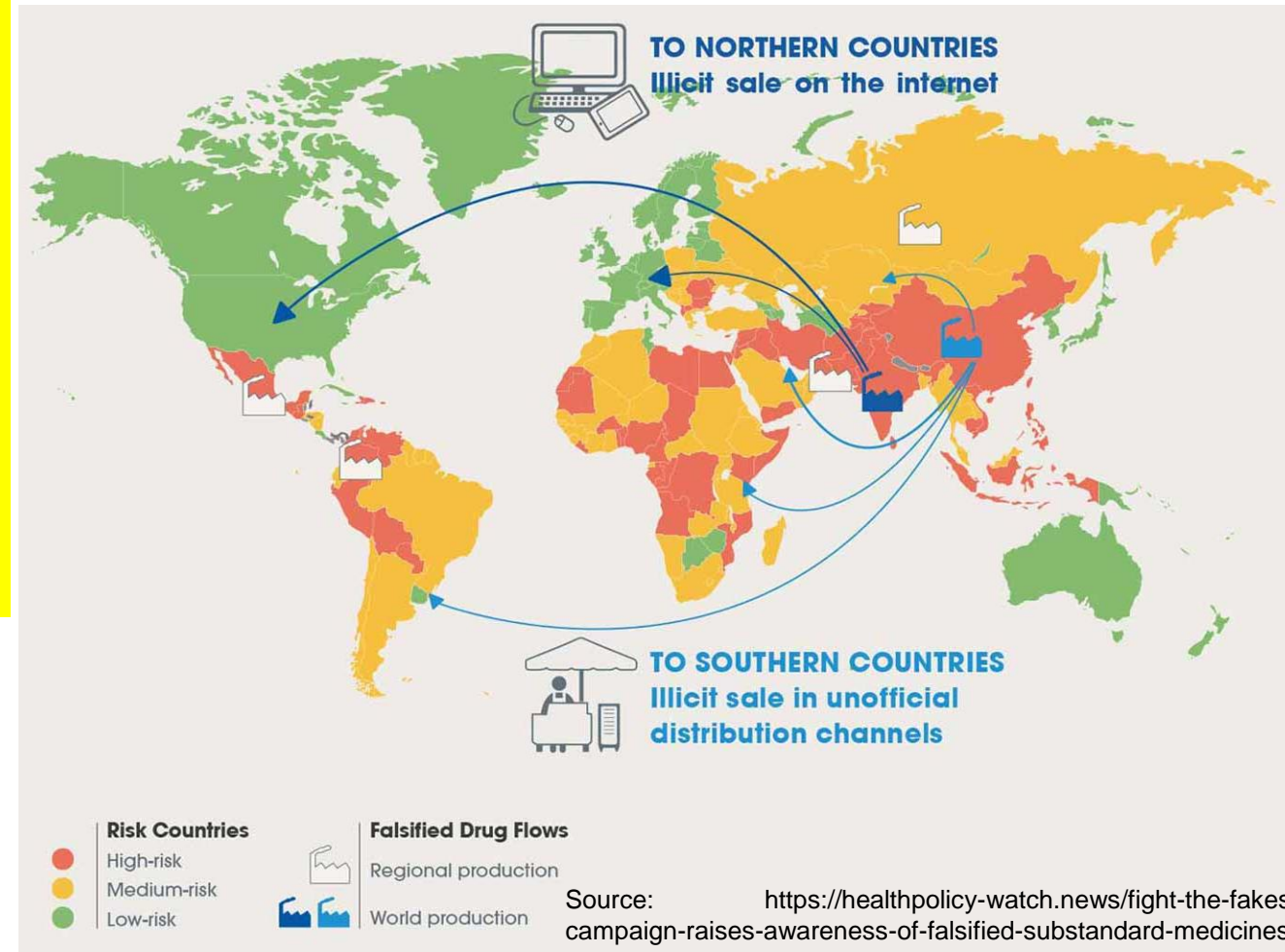

PharmaChain - Counterfeit Free Pharmaceutical

Enterprise Resource Planning

Transaction Ledger

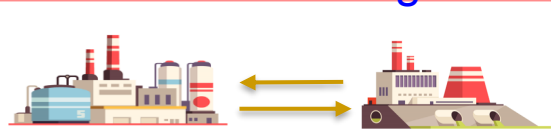

Blind Parties



Manufacturer places order and ingredients are supplied

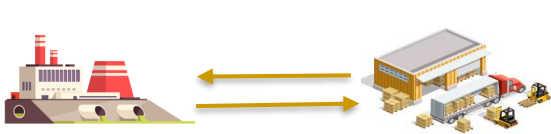

Wholesaler places order from Manufacturer

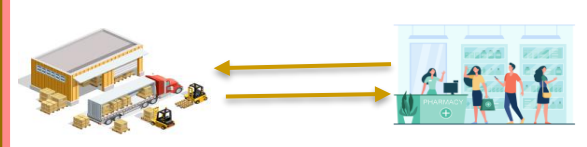

Transfer of drugs from wholesaler to pharmacy

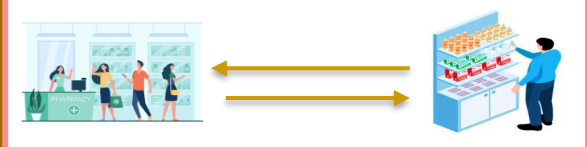

Prescribed medicines are dispensed to the consumer

Blockchain System

Blockchain Ledger

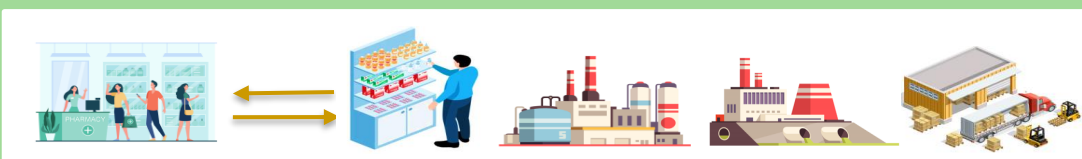
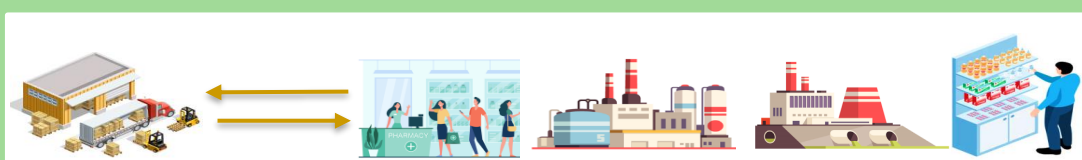

Ingredients

Manufacturer

Wholesaler

Consumer

Transparent Ledger

Pharmacy

Source: A. K. Bapatla, **S. P. Mohanty**, E. Kougianos, D. Puthal, and A. Bapatla, "PharmaChain: A Blockchain to Ensure Counterfeit-Free Pharmaceutical Supply Chain", *IET Networks*, Vol. XX, No. YY, ZZ 2022, pp. Accepted on 24 June 2022, DOI: <https://doi.org/10.1049/ntw2.12041>. (Dataset for Research: GitHub)

Our PharmaChain: Architectural Overview

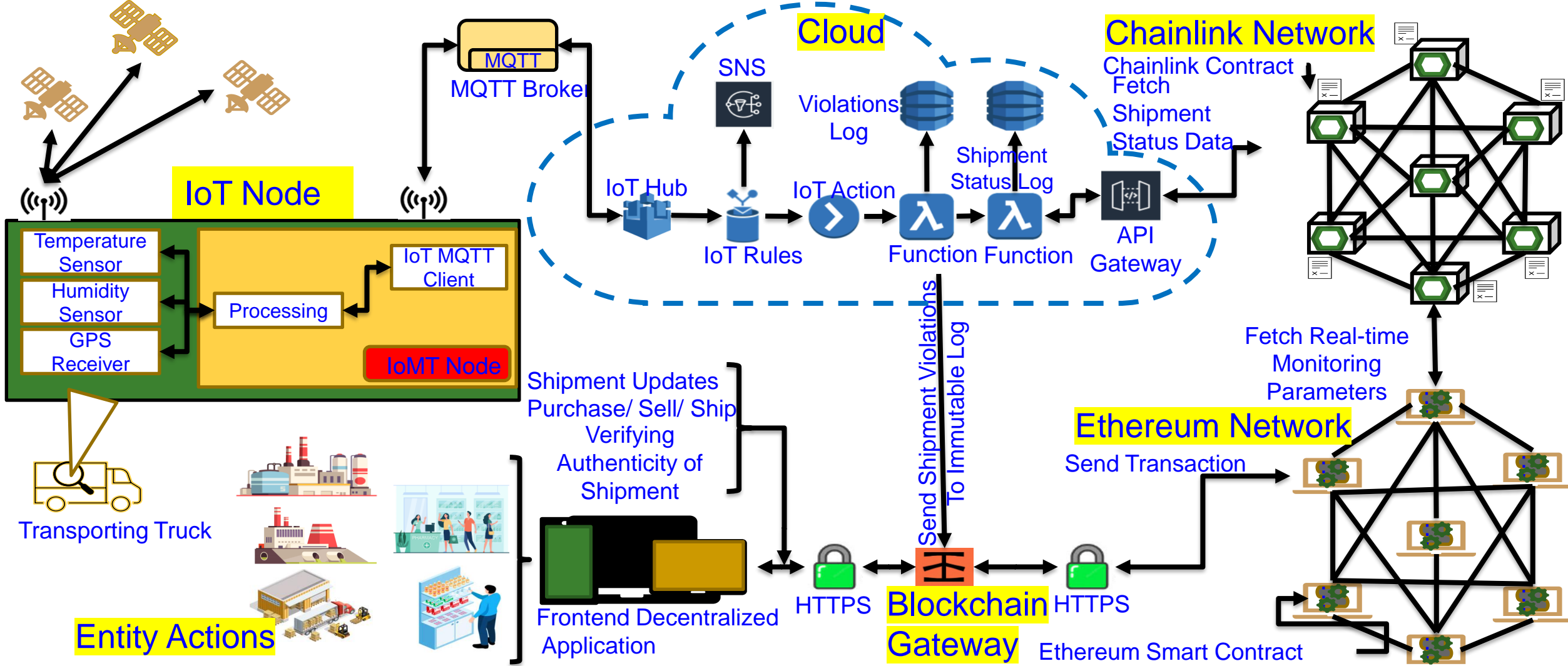

Source: A. K. Bapatla, S. P. Mohanty, E. Kougianos, D. Puthal, and A. Bapatla, "PharmaChain: A Blockchain to Ensure Counterfeit-Free Pharmaceutical Supply Chain", *IET Networks*, Vol. 12, No. 2, March 2023, pp. 53--76, DOI: <https://doi.org/10.1049/ntw2.12041>. (Dataset for Research: [GitHub](#))

PharmaChain Entity Diagram

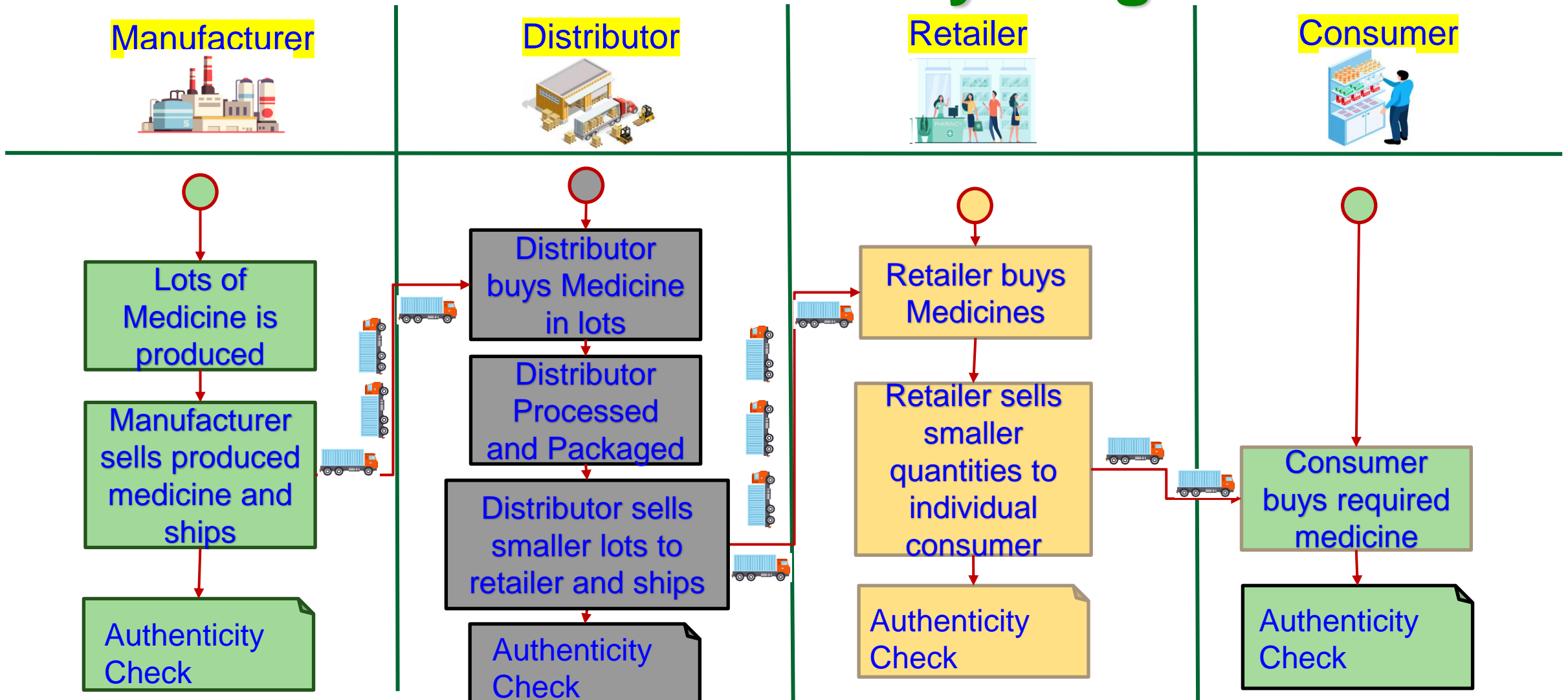

Source: A. K. Bapatla, **S. P. Mohanty**, E. Kougioukos, D. Puthal, and A. Bapatla, "PharmaChain: A Blockchain to Ensure Counterfeit-Free Pharmaceutical Supply Chain", *IET Networks*, Vol. 12, No. 2, March 2023, pp. 53--76, DOI: <https://doi.org/10.1049/ntw2.12041>. (Dataset for Research: [GitHub](#))

PharmaChain 2.0 - Architecture Overview

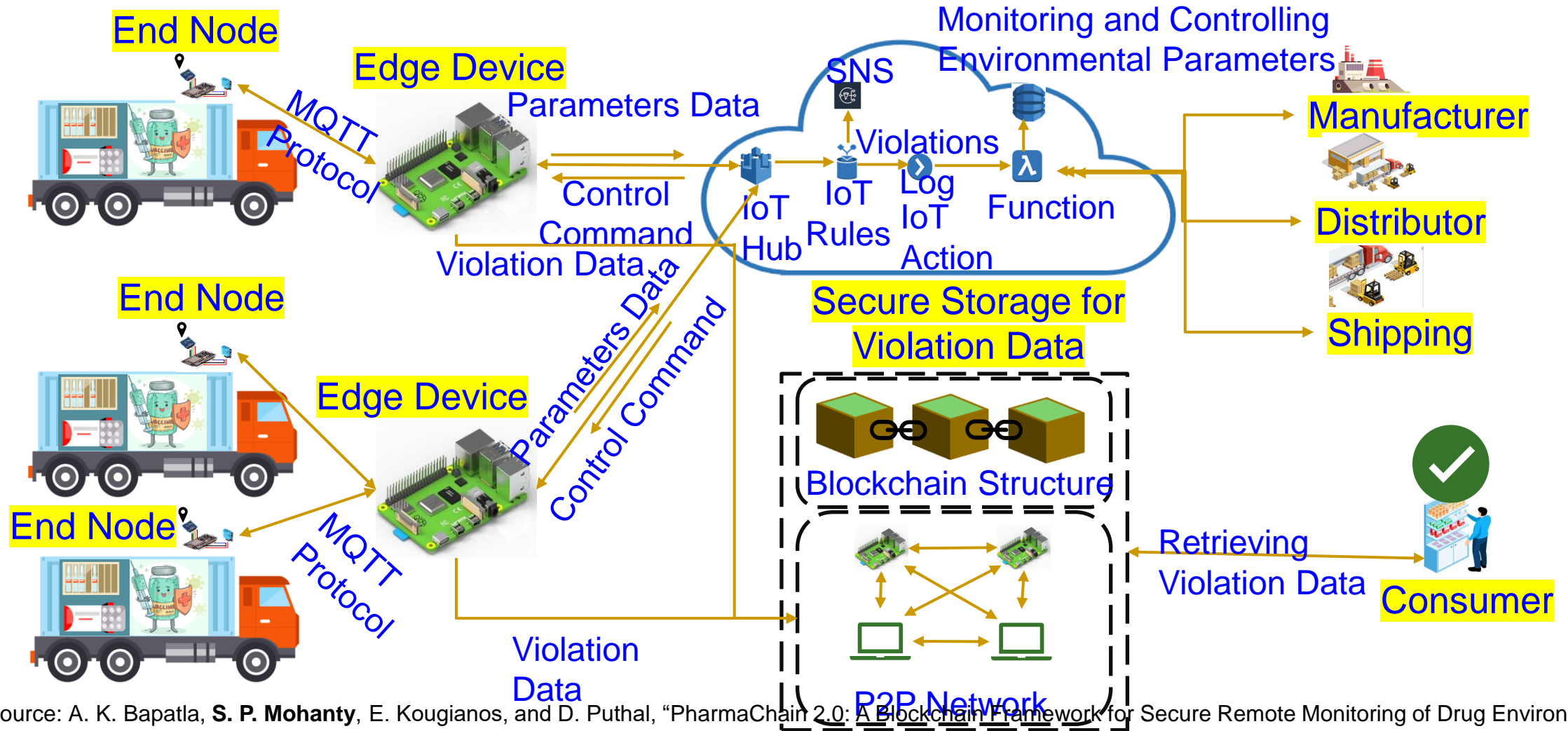

Source: A. K. Bapatla, **S. P. Mohanty**, E. Kougianos, and D. Puthal, "PharmaChain 2.0: A Blockchain Framework for Secure Remote Monitoring of Drug Environmental Parameters in Pharmaceutical Cold Supply Chain", in *Proceedings of the IEEE International Symposium on Smart Electronic Systems (iSES)*, 2022, pp. 185--190, DOI: <https://doi.org/10.1109/iSES54909.2022.00046>.

PharmaChain 2.0 - Comparative Analysis

Comparison of Proposed PharmaChain 2.0 solution with Existing Solutions

| Features | Blockchain | Consensus Protocol | Openness | IoT Friendly Consensus | Average Time |
|---------------------------------|---------------------------------|--------------------------------|----------|------------------------|--------------|
| CryptoCargo [15] | Ethereum | Proof-of-Work (PoW) | Public | No | 43.36 sec |
| PharmaChain [9] | Ethereum | Proof-of-Authority (PoA) | Private | No | 5.6 sec |
| Current Paper (PharmaChain 2.0) | PoAh Consensus Based Blockchain | Proof-of-Authentication (PoAh) | Private | Yes | 322.28ms |

Source: A. K. Bapatla, **S. P. Mohanty**, E. Kougianos, and D. Puthal, "PharmaChain 2.0: A Blockchain Framework for Secure Remote Monitoring of Drug Environmental Parameters in Pharmaceutical Cold Supply Chain", in *Proceedings of the IEEE International Symposium on Smart Electronic Systems (iSES)*, 2022, pp. Accepted.

PharmaChain 3.0 - Architectural Overview

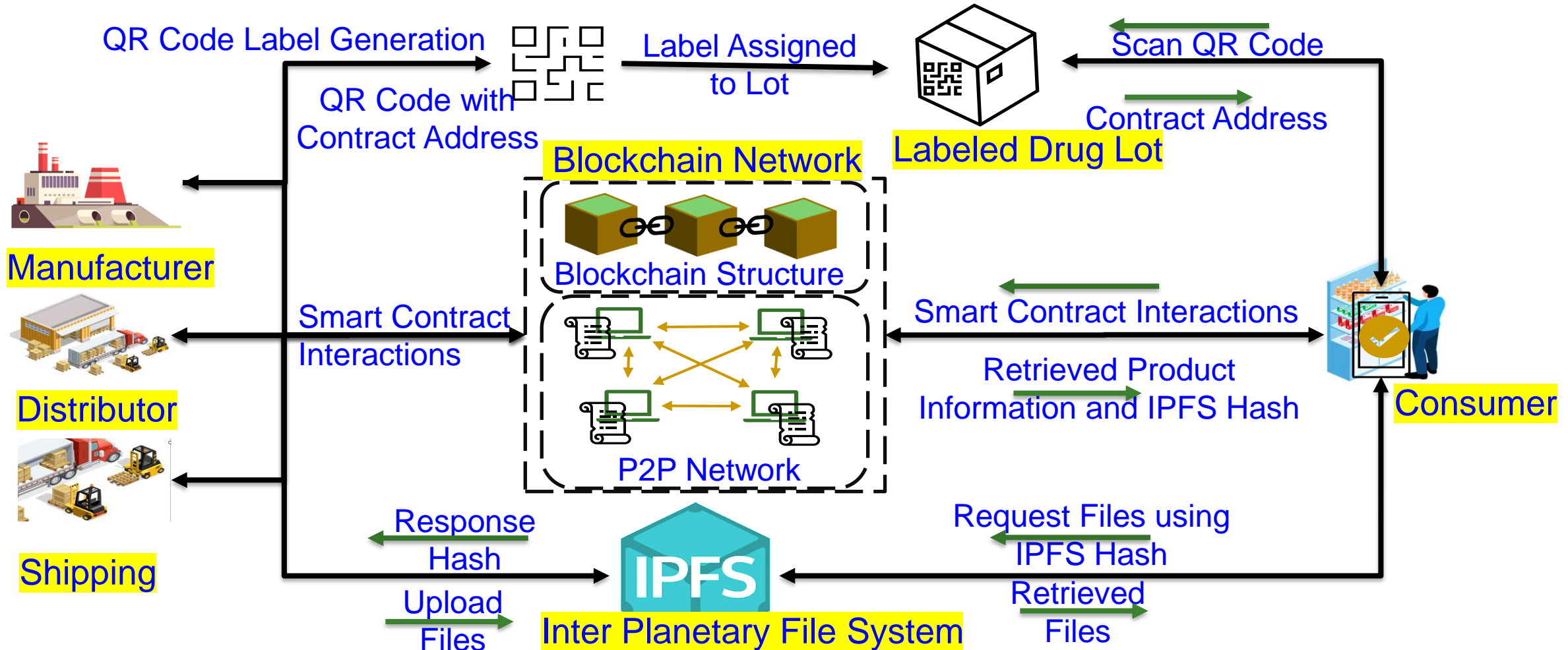

Source: A. K. Bapatla, **S. P. Mohanty**, and E. Kougianos, "PharmaChain 3.0: Efficient Tracking and Tracing of Drugs in Pharmaceutical Supply Chain using Blockchain Integrated Product Serialization Mechanism", *Springer Nature Computer Science (SN-CS)*, Vol. 5, No. 1, Jan 2024, Article: 149, 22-pages, DOI: <https://doi.org/10.1007/s42979-023-02510-9>.

PharmaChain 3.0 – The Key Idea

0x1EcbFd5Edb3747927033
Aa893416e4aD01DF0c6E

Lot Contract Address

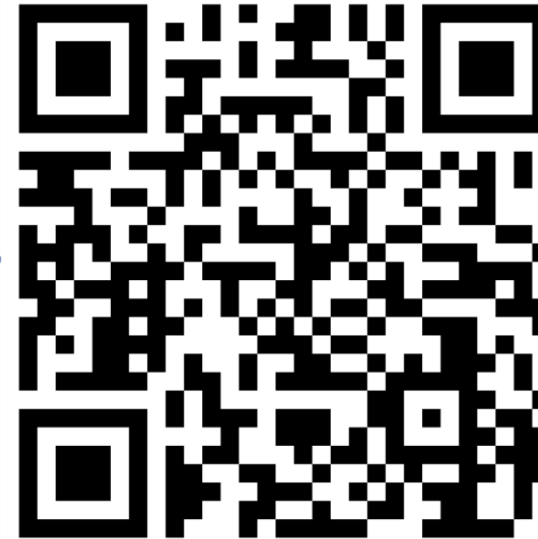

QR Code Generated for Lot Labelling

New Lot Contract Address Converted to QR Code for Labeling

Source: A. K. Bapatla, **S. P. Mohanty**, E. Kougianos, and D. Puthal, "PharmaChain 3.0: Blockchain Integrated Efficient QR Code Mechanism for Pharmaceutical Supply Chain", in *Proceedings of the OITS International Conference on Information Technology (OCIT)*, 2022, pp. Accepted.

PharmaChain 3.0 - Comparative Analysis

| Works | Blockchain | Consensus Mechanism | Computational Needs | Openness | QR Code Integrated | Storage | Handling Large data |
|------------------------------------|---------------|--------------------------------|---------------------|----------|--------------------|------------------------|---------------------|
| Crypto Cargo [11] | Ethereum | Proof-of-Work (PoW) | High | Public | No | On-Chain and Cloud | No |
| Kumar et.al. [9] | NA | NA | NA | NA | Yes | On-chain | No |
| PharmaChain [12] | Ethereum | Proof-of-Authority (PoA) | Low | Private | No | On-Chain and Cloud | No |
| PharmaChain 2.0 | Our EasyChain | Proof-of-Authentication (PoAh) | Low | Private | No | On-Chain and Cloud | No |
| Current Solution (PharmaChain 3.0) | Ethereum | Proof-of-Stake (PoS) | Low | Private | Yes | On-Chain and off-Chain | Yes |

Smart Healthcare – Trustworthy Medical Prescription

Electronic Prescription

- Revolutionized the way medications are prescribed, processed, and dispensed
- Digital version of prescriptions increase legibility and reduces medication errors
- Clinical Decision Support Tools – Warn potential drug interactions, suggest alternate medication, offer dosage recommendations

- More than 100,000 reports of medication errors (FDA)
- 40% of Americans report being involved in medical errors (Institute for Healthcare Improvement/NORC at the University of Chicago)
- 1 in 5 doses of medication provided during patient visits is administered incorrectly

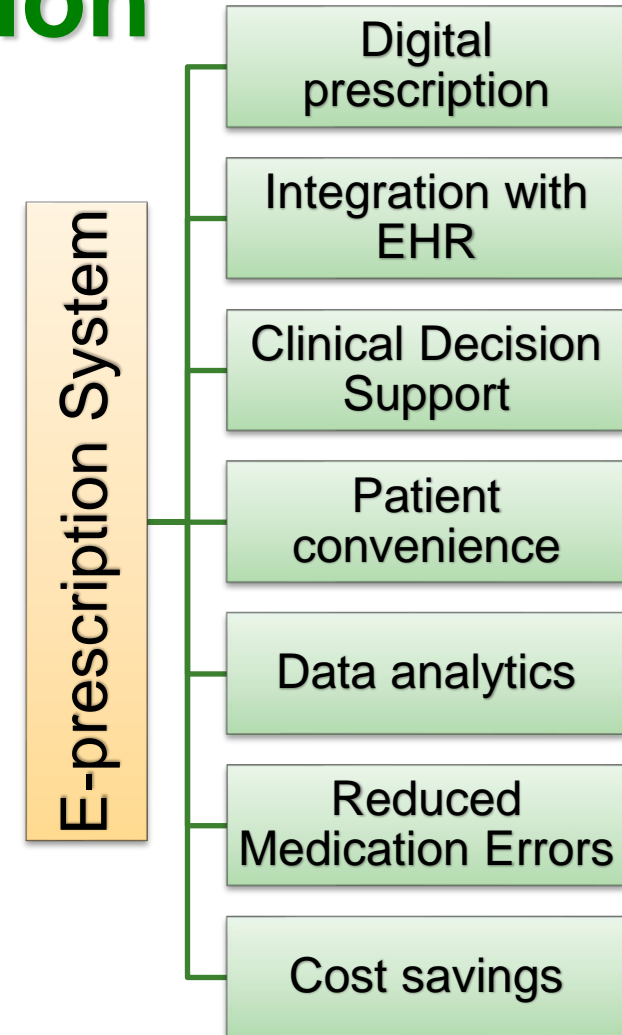

Source: A. K. Bapatla, S. P. Mohanty, and E. Kougianos, "FortiRx: Distributed Ledger Based Verifiable and Trustworthy Electronic Prescription Sharing", in *Proceedings of the IFIP International Internet of Things Conference (IFIP-IoT)*, 2023, pp. 283--301, DOI: https://doi.org/10.1007/978-3-031-45882-8_19.

E-Prescription System and Issues

- Single Point of Failure (SPOF)
 - Data Security
 - Privacy Concerns
 - Interoperability Concerns (PDMP)
 - System availability Issues
- Prescription Drug Monitoring Programs (PDMP) help mitigate prescription misuse and diversion
 - Oversight of controlled substance prescriptions

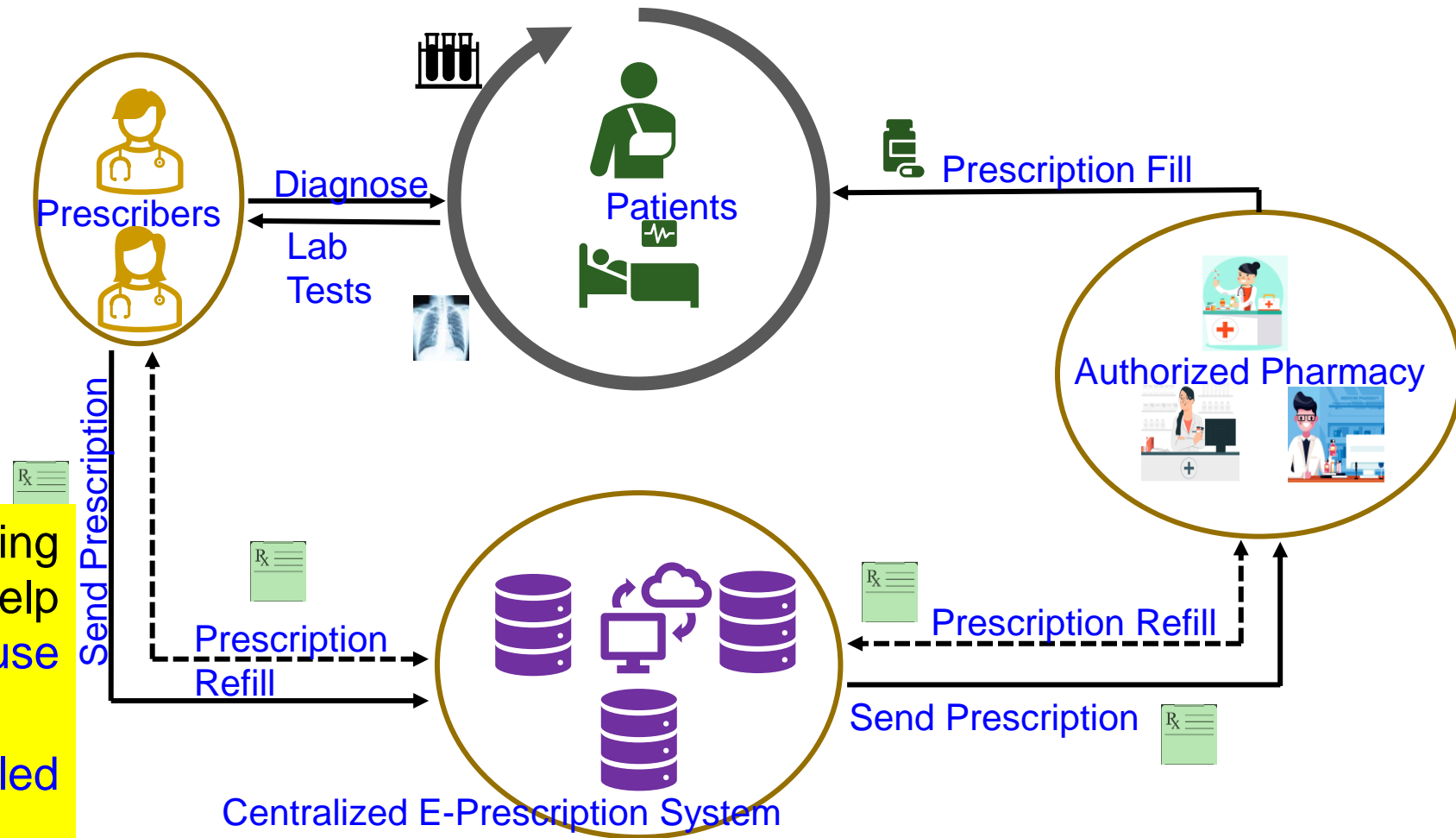

Source: A. K. Bapatla, **S. P. Mohanty**, and E. Kougianos, "FortiRx: Distributed Ledger Based Verifiable and Trustworthy Electronic Prescription Sharing", in *Proceedings of the IFIP International Internet of Things Conference (IFIP-IoT)*, 2023, pp. 283--301, DOI: https://doi.org/10.1007/978-3-031-45882-8_19.

E-Prescription is the Need of the Hour

| Prescription Drug Type | Annual Abusers | % Among Rx Abusers | % Among Americans |
|------------------------|----------------|--------------------|-------------------|
| Painkillers | 9.7 million | 59.5% | 3.43% |
| Opioids Alone | 9.3 million | 57.1% | 3.29% |
| Sedatives | 5.9 million | 36.2% | 2.08% |
| Stimulants | 4.9 million | 30.1% | 1.73% |
| Benzodiazepine Alone | 4.8 million | 29.4% | 1.70% |
| All Prescription Drugs | 16.3 million | 100% | 5.76% |

Reduced Fraud and Abuse

Blockchain Immutability
Combats prescription fraud and abuse

Enhanced Security and Privacy:

Provides security and integrity of the medical data

Efficiency and Accuracy

Accuracy can be improved to reduce medication errors

Interoperability

Seamless data exchange between healthcare providers

Addressing Opioid Crisis

Prevents misuse and abuse of opioids

- 16M – 6% of Americans over the age of 12 abuse prescriptions in a year.
- 2M – 12% of prescription drug abusers are addicted.

Statistics Source: <https://drugabusestatistics.org/prescription-drug-abuse-statistics/>

Our FortiRx: Architecture Overview

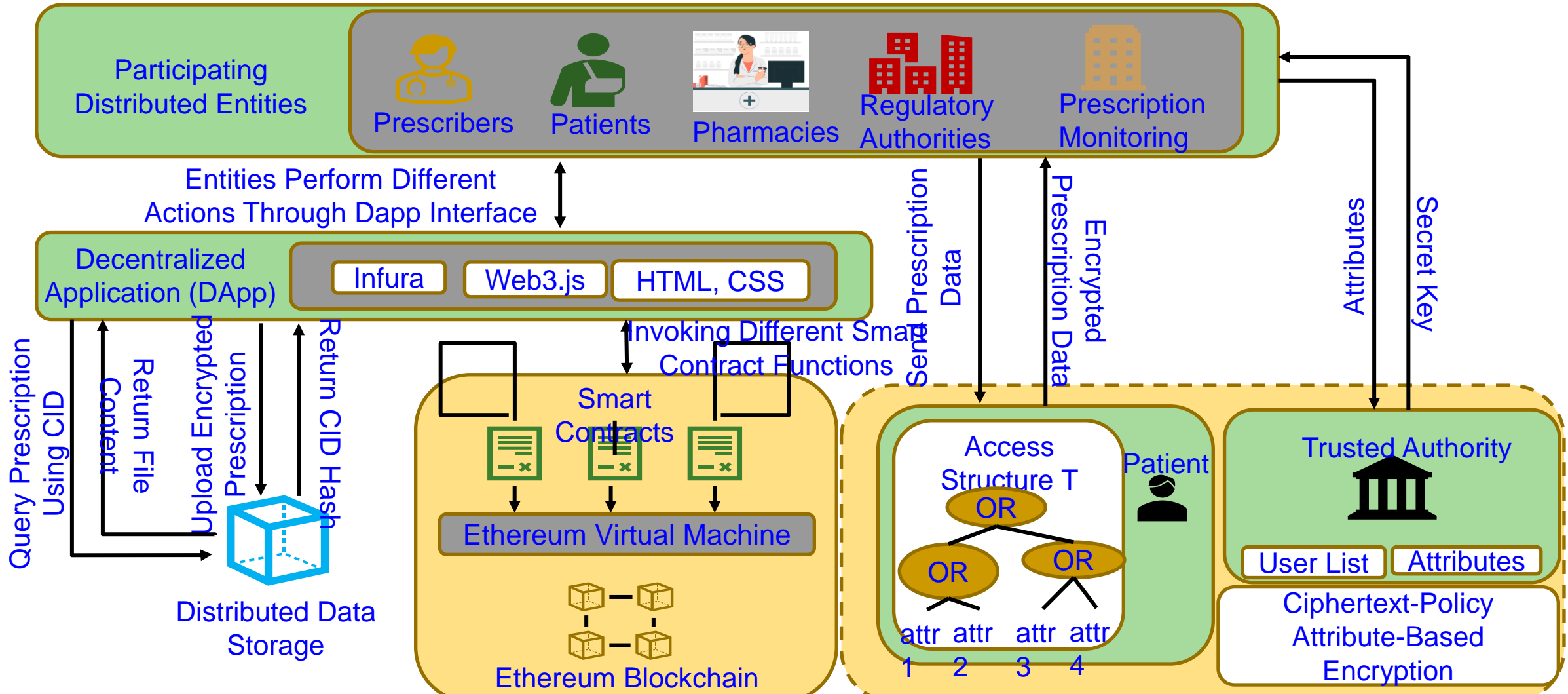

Source: A. K. Bapatla, **S. P. Mohanty**, and E. Kougianos, "FortiRx: Distributed Ledger Based Verifiable and Trustworthy Electronic Prescription Sharing", in *Proceedings of the IFIP International Internet of Things Conference (IFIP-IoT)*, 2023, pp. 283--301, DOI: https://doi.org/10.1007/978-3-031-45882-8_19.

FortiRx: Smart Contract Deployment

Deployment in Sepolia

Smart Contract

Wallet Transaction

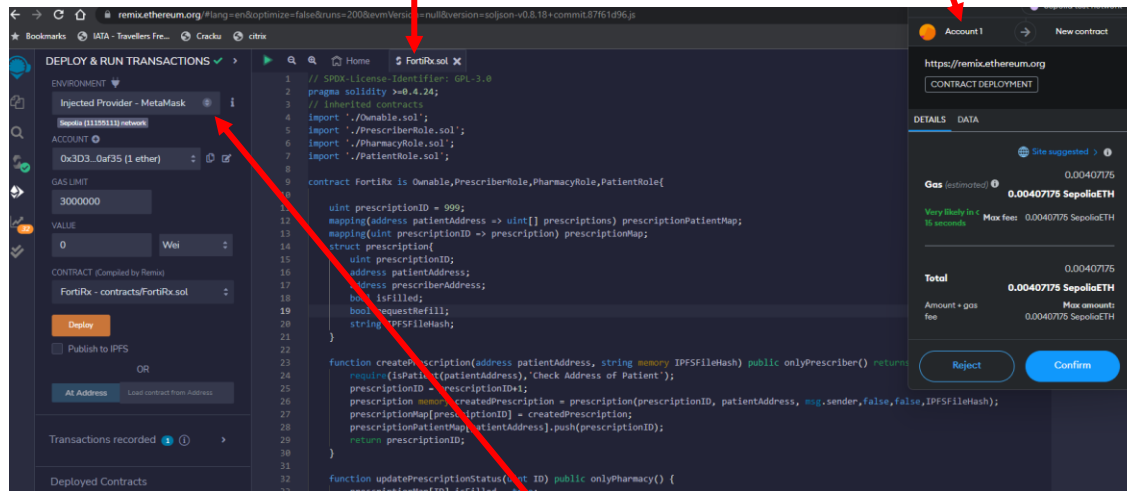

Ethereum Addresses with Roles

| Feature | Value |
|----------------------------|--|
| Physician Account Address | 0x3d352313f4f5561d0ffbfa205b52a3c3b70af35 |
| Pharmacy Account Address | 0x3D352313F4f5561D0ffbfa205B52A3c3b70af35 |
| Patient Account Address | 0x2a9884dfa7E6890FE8AA99FE2486c613C32b697a |
| Contract Deployment Hash | 0x798d1f5ff49f9df09b9856db2646cebc2029d5cd2a45c5ef0c1b9acb9f217c6f |
| Prescription Content ID | Qme7Sq8gLmE875kE79QyWWFy9wqQ4yHnTEHMur511PrZff |
| Prescription Creation Hash | 0xda5bd0ce943325696e91bfe140bd8cdd60eafda6f2a41b07221e499bfe7f1f7 |

Remix Environment Network Configuration

Source: A. K. Bapatla, S. P. Mohanty, and E. Kougianos, "FortiRx: Distributed Ledger Based Verifiable and Trustworthy Electronic Prescription Sharing", in *Proceedings of the IFIP International Internet of Things Conference (IFIP-IoT)*, 2023, pp. 283--301, DOI: https://doi.org/10.1007/978-3-031-45882-8_19.

FortiRx: Transaction Confirmation Times

Smart Contract Function vs Average Transaction Time (Sec)

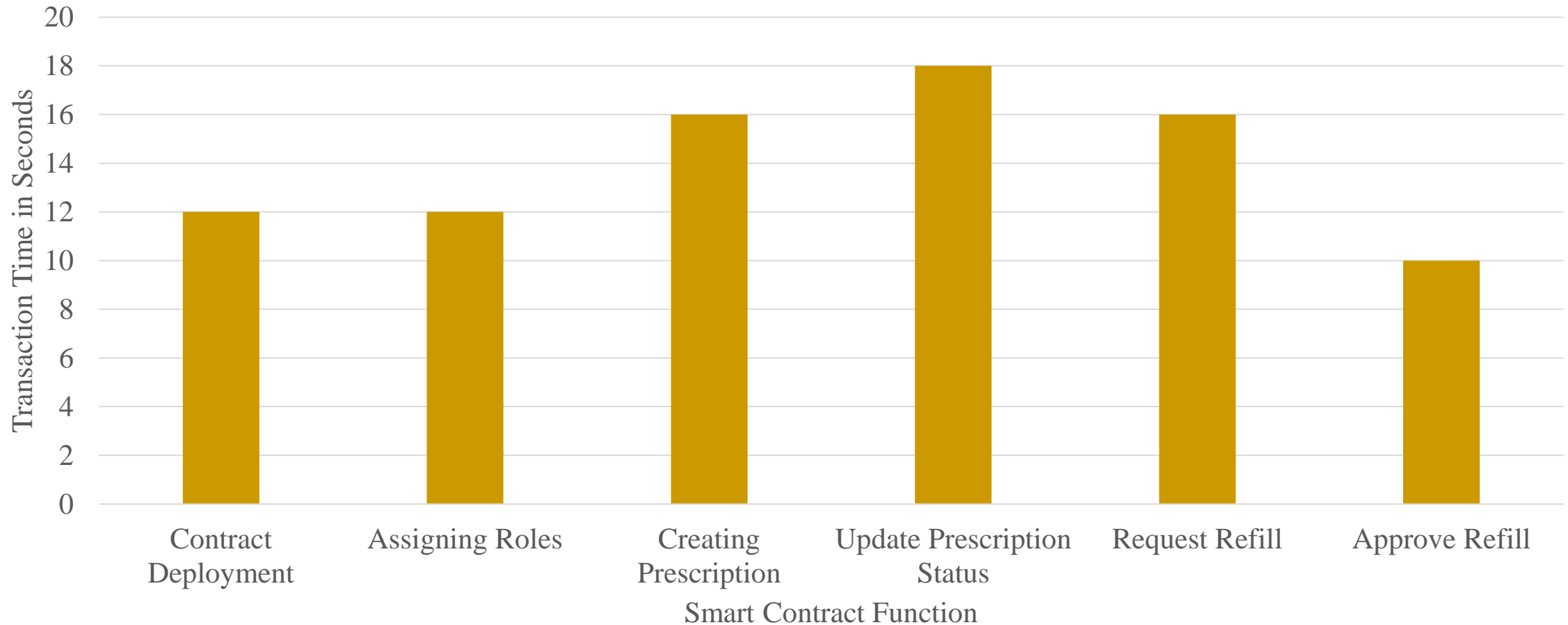

Source: A. K. Bapatla, **S. P. Mohanty**, and E. Kougianos, "FortiRx: Distributed Ledger Based Verifiable and Trustworthy Electronic Prescription Sharing", in *Proceedings of the IFIP International Internet of Things Conference (IFIP-IoT)*, 2023, pp. 283--301, DOI: https://doi.org/10.1007/978-3-031-45882-8_19.

Our FortiRx 2.0: Architecture

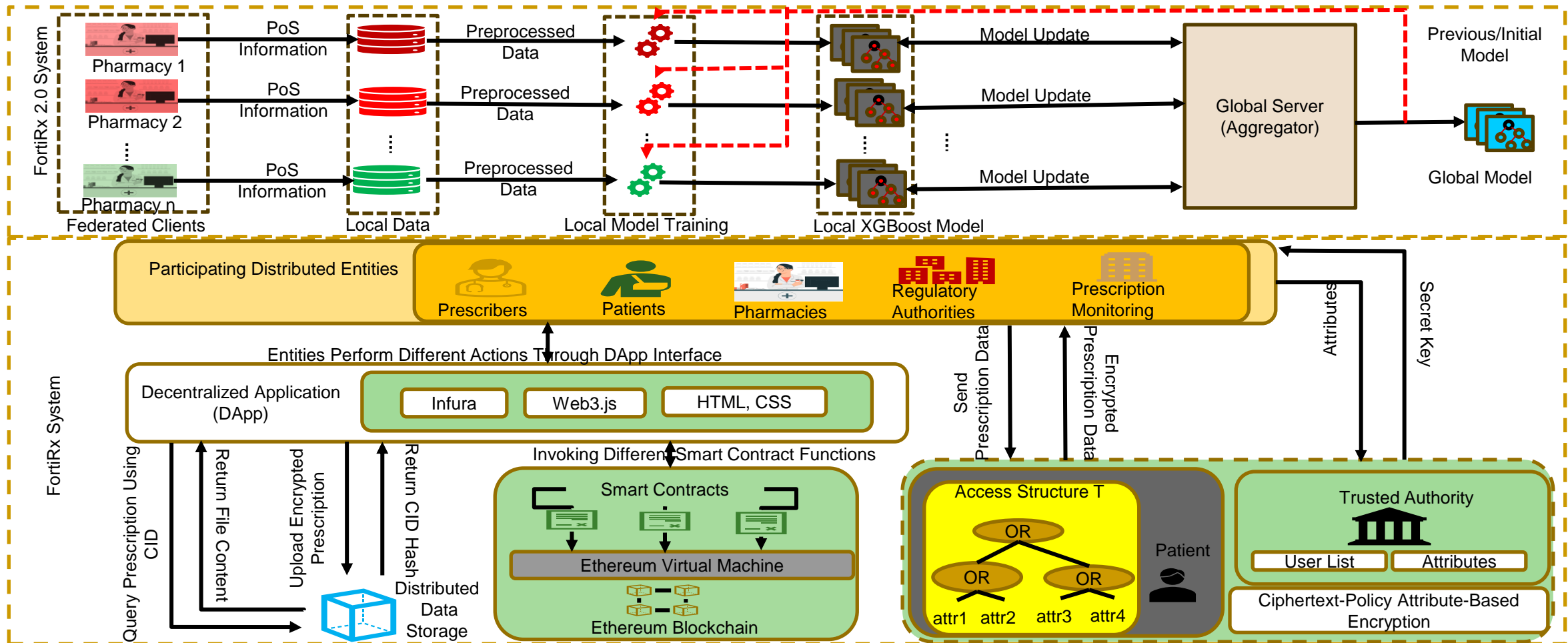

Source: A. K. Bapatla, **S. P. Mohanty**, and E. Kougiianos, "FortiRx 2.0: Smart Privacy-Preserved Demand Forecasting of Prescription Drugs in Healthcare-CPS", in *Proceedings of the OITS International Conference on Information Technology (OCIT)*, 2023, pp. 438--443, DOI: <https://doi.org/10.1109/OCIT59427.2023.10430944>.

FortiRx – A Comparative Perspective

| Works | Blockchain Platform | Prescription Privacy | Data Management | Drug Demand Forecasting |
|--|---------------------|--------------------------------------|------------------------|-------------------------|
| Ionescu et al, SmartBlock4Health, 2022 | Ethereum | Asymmetric Encryption | On-chain | ✗ |
| VigilRx, 2022 | Ethereum | Role-Based Access Control | On-Chain | ✗ |
| FortiRx, 2023 | Ethereum | Role-Based Access Control and CP-ABE | On-chain and off-chain | ✗ |
| FortiRx 2.0 | Ethereum | Role-Based Access Control and CP-ABE | On-chain and off-chain | ✓ |

Source: A. K. Bapatla, **S. P. Mohanty**, and E. Koungianos, “[FortiRx 2.0: Smart Privacy-Preserved Demand Forecasting of Prescription Drugs in Healthcare-CPS](https://doi.org/10.1109/OCIT59427.2023.10430944)”, in *Proceedings of the OITS International Conference on Information Technology (OCIT)*, 2023, pp. 438--443, DOI: <https://doi.org/10.1109/OCIT59427.2023.10430944>.

Research – Best Practices

Why Do I Need a Ph.D.?

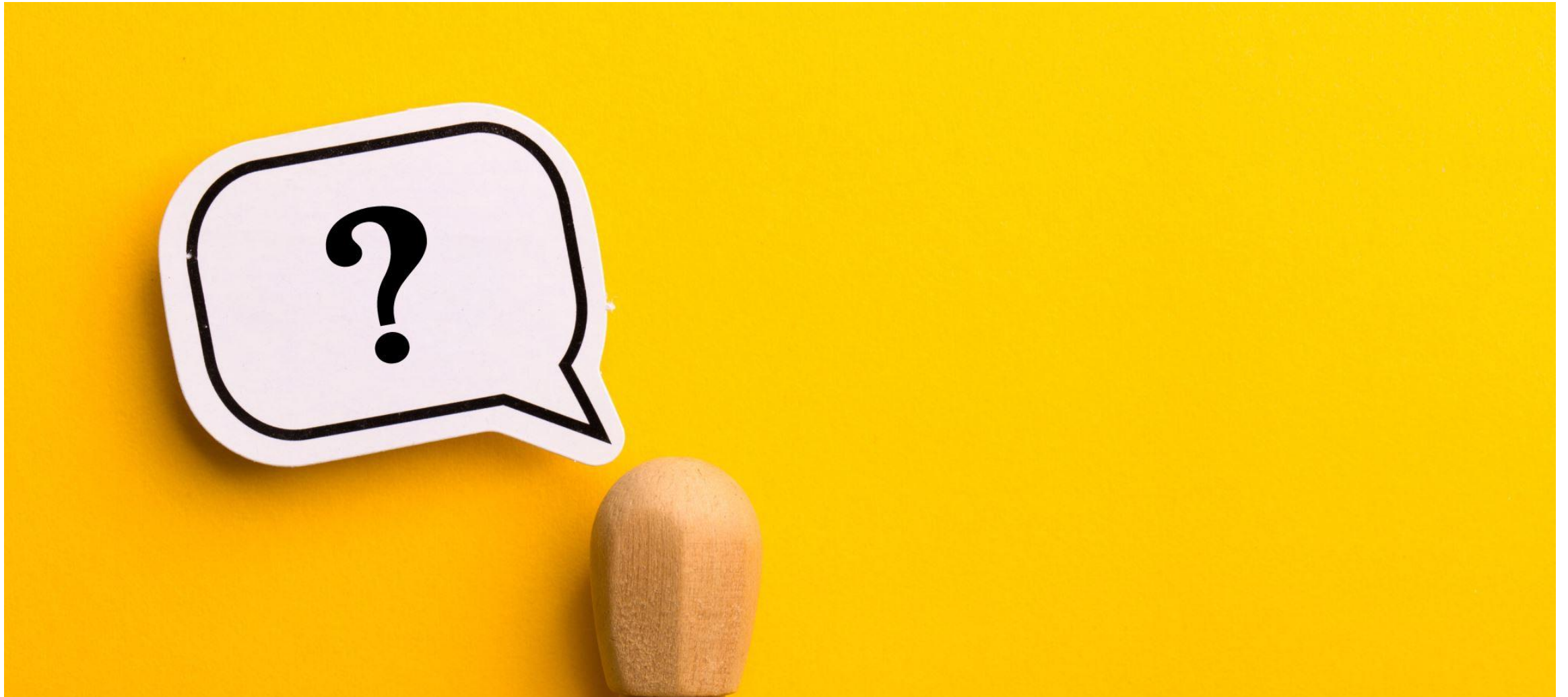

“Dr.” Infront of Name, The Title

“Dr.” allowed to use before name:

- Dr. First-Name Last-Name

“Mr.”, “Ms.”, etc. for rest all degrees

An Honor in itself

Become an Expert in Field

Build on your knowledge from your Master's degree by engaging with complex topics in field of your choice.

Superspecialized

Bachelors – Broad

Masters – Specialized

Ph.D/Doctoral - Superspecialized

Improvement in Soft Skills



During a doctorate degree process one develops many of the soft skills that employers look for in applicants.



Education Process
→

Improves time management skills

Improves problem solving skills



Education Process
→

Improves critical thinking

Improves patience

Improves adaptability

Source: <https://www.careeraddict.com/should-phd>

Accumulation of Extensive Network of Professional Colleagues



During Ph.D. studies one works closely with professors, department chairs/heads, experts in a field, and fellow researchers.



This network of colleagues and researchers provides continual assistance with recommendations, references, job leads, and career growth.

Source: <https://www.careeraddict.com/should-phd>

Access to Most Prestigious Jobs/Positions



Ph.D. is the highest formal degree that one can earn.



Opens doors to careers at the highest levels.



Include leadership positions in science and engineering.



Ph.D. is a must for Tenure-Track Positions.

Source: <https://www.careeraddict.com/should-phd>

Challenges of a Ph.D.



Expensive



Lonely Experience



Stress and Frustration



Job Opportunities Reduces due to Highest Qualification



Less Financial Reward as Compared to Education

Source: <https://www.careeraddict.com/should-phd>

Golden Rules of Writing a Ph.D. Dissertation/Thesis

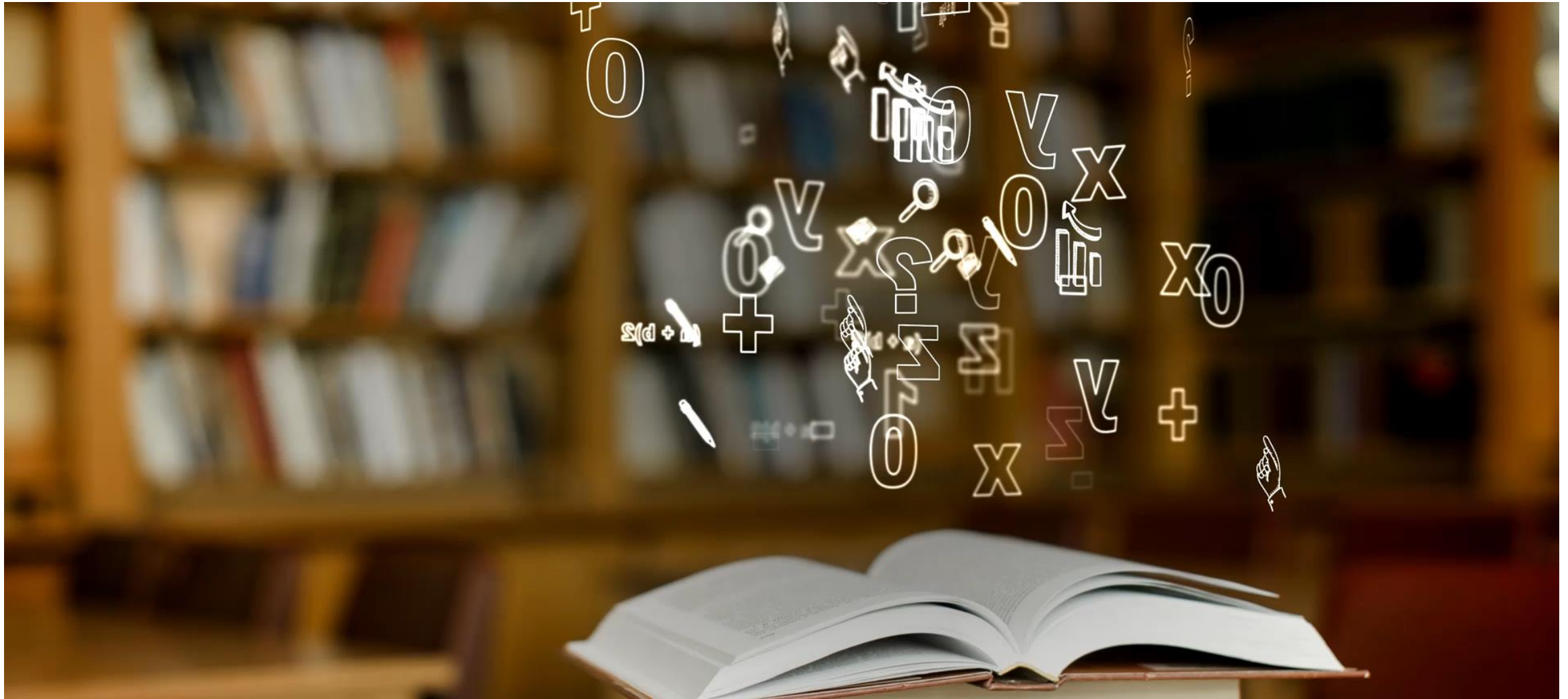

Ph.D. Dissertation/Thesis



Keep in Mind: An Independent Document that needs to sustain for years.



One should be proud of seeing this in a library decades after it is written and defended.

Typical Structure of a Ph.D. Dissertation/Thesis - Various Chapters



Abstract



Introduction (Include Novel Contributions Section)



Related Prior Works



Innovative Chapters – 3/4 of these



Experimental Results



Conclusion

Golden Rules of Writing a Research Paper



Typical Structure of a Research Paper - Various Section

- Abstract
- Introduction
- Novel Contributions
- Related Prior Works
- Innovative Sections – Few of them to sale the paper
- Experimental Results
- Conclusions
- Future Directions

A Quick Check of the Contents of a Manuscript

Manuscript Evaluation

| | | |
|--|--|---|
| Language <ul style="list-style-type: none">• Inclusive Language• Plain Language Summary• Grammar• Mechanics and Style• Readability• Vocabulary | Structure <ul style="list-style-type: none">• Manuscript Structure• Structured Abstract | Disclosures <ul style="list-style-type: none">• Author Contributions Statement• Conflict of Interest Statement• Data Access Statement• Ethics Statement• Funding Statement |
| References <ul style="list-style-type: none">• Age of References• No Citations in Abstract• Number of References• Reference Citations | Counts <ul style="list-style-type: none">• Abstract Length• Manuscript Length• Title Length• Use of Brand Names• Use of Copyrighted Methods | Metadata <ul style="list-style-type: none">• Corresponding Author's Email Address• List of Contributing Authors• List of Keywords• Word Count |
| | Figures and tables <ul style="list-style-type: none">• Figure and Table Citations• Figure Legends | |

Source: https://twitter.com/Faheem_uh/status/1705131512210035159

A Good Way to Work on a Research Paper

- Overall Skeleton using tentative Sections
- Draw the figures for various Sections
- Generate the Plots
- Generate the Tables
- Write the Text
- Iteratively Improve

Rules of Patent Filing



Why is it Important to Patent My Research Idea?

- Patent Provides Exclusive Right
- Patent Provides Competitive Advantage
- Technology Transfer
- Potentials for Financial Returns
- Increase Valuation
- Attract Investment
- Helps to Obtain Funding
- Satisfaction to see Lab Research → Mass Product

Source: <https://henrygoh.com/top-10-reasons-why-a-patent-is-important/>

What is the Right Time to File the Patent?

Before Publishing the research

- OR

After Publishing the research

Rules to Balance Patents and Publications



File a patent before you present or publish your work in the public domain to be fully careful.



Be careful while presenting your idea or writing an abstract.



Avoid providing too many details that can enable a 3rd party to copy your invention.



Present only broadly outline your ideas while discussing with potential organizations or companies.



If you intend to have business discussions with a 3rd party, ensure that a none-disclosure agreement (NDA) is in place prior to the discussions.

Source: <https://www.enago.com/academy/publish-or-patent-first>

Patent – Key Points



Something extraordinarily novel idea so that we protect it.



Incremental innovations can not be patented.



It costs money to file.



Inventors write the technical details.



Lawyers write the patent text with innovations, claims, etc.

Research Publishing – Best Practices



Publishing Venue – Where to Publish?

- Magazine, Transactions, Letters, or Conference Proceedings?
- Depends on the content of a manuscript.
- First fix a venue → Write? **OR** First Write → venue?
- **Magazine Article** – Broad scope
- **Journal/Transactions Papers** – Focused scope and concrete results
- **Letters Papers** – Focused scope and brief results
- **Conference Proceedings Papers** – Focused scope and quick dissemination to receive direct feedback from peers

Publishing Venue – Magazine?

- Articles should be broadly scoped.
- Technical articles may be suitable, but these should be of general interest to an engineering audience and of broader scope than archival technical papers or conference proceedings papers.
- Articles related to the background story behind engineering standards or practical experiences in product specification and design of mainstream systems.
- Tutorials on related technologies or techniques are also strongly encouraged.

Publishing Venue – Journal/Transactions?



Journal/Transactions are archival venues, just not intended for quick dissemination of research.



Articles should have both depth and breadth.



The work should have strong novelty. It must advance the state-of-the-art to be published.



The work should stand for decades without being outdated.



The experimental results need to be rigorous.



Manuscripts need to survive multiple iterations of review process.



Long Review Cycles. So authors should pay attention to every minor detail. It may get one more round of revision just for a minor issue.

Publishing Venue – Conference Proceedings?

Conference Publishing may be for quick dissemination.

Conference Presentations facilitates direct interaction with peers.

Conference attendance may help researchers in their career advancement.

Conference reviews can help to improve the work further which may then eventually become a journal publishing.

Work-in-Progress (WIP) and Research-Session-Demo (RDS) are alternative modes of dissemination to get feedback on ongoing research from the peers.

Conference → Journal OR Journal → Conference?

- Conference publishing first → corresponding journal
OR

Journal publishing first → corresponding conference

- To my experience: I see that most of the researchers follow the first option and few researchers follow the second option.
- In either case one shouldn't have the same text and figures.
 - These are two distinct publications for the authors.
 - After acceptance both the journal paper and conference paper appear in digital library, a **similarity software will flag** the similarity.

Shall I Target Journal/Transactions Submission Directly Without a Conference Paper of the Work?



Short Answer: No



Reviews received from the Initial Conference Version of the work can strengthen the work to become a journal paper eventually.



Reviewers of the journal manuscript can have better impression if they find that it is already based on a quality conference paper.



Journal have longer review cycle which may not correctly timestamp the idea published in the journal paper. Imagine rejection of the journal manuscript after 6-8 months of review cycle, losing the time.

Conference → Journal: How to Do it?



Publisher need anywhere between 30%-70% additional materials over the conference version for a journal article.



Final judgement is typically up to the Editor-in-Chief (EiC) of specific journal/transactions.



Key aspects of extending a conference paper to a journal article: additional novel contributions, thorough literature analysis, more experimental results, additional figures, and additional Tables.



Complete rewriting of the text and redrawing of any figures used is a good idea to avoid similarity issues and the copyright aspects as in many cases the publishers conference proceedings and the journal/transactions may not be the same.



Remember to cite the conference paper on the current journal paper; may be even write in the acknowledgement.

Journal → Conference: How to Do it?

- It is not common to present a journal published paper as a conference paper.
- Things are changing – Too many conference looking for audience
- Short conference paper as possible option
- Research Demo Session (RDS) papers is another option
- Complete rewriting of the text and redrawing of any figures used is a good idea to avoid similarity issues and the copyright aspects as in many cases the publishers of conference proceedings and the journal/transactions may be different.
- Remember to cite the journal paper on the current conference paper; may be even write in the acknowledgement.

Is it Important to Suggest Reviewers Names when Submitting a Journal/Transactions Manuscript?

- Short Answer: Yes
- Associate Editors are typically overloaded, they may pick few of the reviewers from your suggested list.
- The manuscript may be handled by an AE who is working on a closely, but not exactly on the area of the manuscript, so may take time to find sufficient reviewers.
- You never know your preferred reviewer may see your work favorably!

How Important is Open-Access Publishing?



Thoughts on the current state of academic publishing

Journal papers are important OR
Conference papers
Open Access is better OR traditional closed access



Thoughts on Open-Access:

Arxiv (<https://arxiv.org/>),
TechRxiv (<https://www.techrxiv.org/>)
Data Regulation –
Quality Data is key



One aspect of academic publishing that is very important/significant these days

Open Access and Research
Reproducibility

Journal Review Process Takes Long Time, Should I Only Publish in Conference?

- Short Answer – No
- Journals are archival purposes and publish thoroughly reviewed works. So quality of work can improve if reviews are good.
- Option to time stamp the idea, before submitting to Journal:
 - Make a conference paper
 - Put it in open access depository like arXiv, TechRxiv, etc.

Journal Review Process Takes Long Time, Should I Submit to Multiple Venues for Faster Publishing?



Short Answer: No



Submitting same manuscript to multiple journals/transactions at a time is not allowed.



Submitting same manuscript to a journals/transactions and a conference at a time is not allowed.



Danger of being rejected without review from multiple venues.

I Can Publish in Journals, Why Should I Bother for Conferences?

- Short Answer – Yes
- Networking with Global Peers
- Direct Interaction with Peers → Boost Researcher's Confidence
- Meet people who can help in job search
- Meet people who can your reference for job search
- Meet people who can be reviewer of your next papers
- Meet people who can be external examiner of thesis/dissertation (if applicable)

Does the Look and Formatting of the Manuscript Matter during Submission?

- Short Answer: Yes
- Note: First Impression Lasts Long
- Reviewer maynot be interested to read details if the manuscript doesn't look professional and clear.
- Look and legibility are important to attract attention.
- Danger of the manuscript being returned without review.

How important is author ordering in a publication?



Short Answer: No definite answer



In some disciplines the faculty mentor is typically the last author.



In some cases, the primary contributor is the first author and other is made based on level of contributions to the work.

How Important is Social Media for Researchers?



Short Answer: Not Much



How important is social media for researchers? Should Ph.D. students invest time in building profiles & networks social media?

Neutral – Publicity + Typical Negativity of social media (Privacy issues)



How challenging do you feel it is for new Ph.D. researchers to get published? Any advice/tips?

Reasonable challenging for new researchers, Conference → Journals

Why Should I Spend Time as a Reviewer?

- Short Answer - Yes
- Early Learning: Researchers who are engaged in cutting-edge research can't find learning materials from the text books. By the time a research findings appear in text book, they are outdated. A researcher can stay up to date and learn from other researcher if he/she reviews their manuscripts.
- Learning Quality expected in a specific journal/conference. Accordingly, one can use that experience to improve own manuscripts before submissions.
- Service to the profession and community.

What are the Best Practices of Publishing?

- Short Answer: No definite answer
- Differs in one area of research to another area of research, from disciplines to another, and from publisher to another publisher. Some rule of thumb:
 - ❑ Publish one idea in one venue
 - ❑ Do best job for all text including references
 - ❑ Give credit to existing literature
 - ❑ Read articles/papers from a target venue before preparing own manuscript
 - ❑ Pay attention to each minor or major aspects; too many small → rejection
 - ❑ Learn to handle rejection

A Big Question – Where to Publish?

- As an author after I have always asked myself:
 - **First Option:** My article is an excellent scholarly product because it got published what my peers think as a selective or top avenue.

OR

- **Second Option:** My article is an excellent scholarly product because it is read and/or cited by my peers and it makes the avenue great wherever it is published.
- Most of the researchers have a tendency to choose the first option from the above.
- However, I strongly believe that if an article has real strength then it should be second option.

Academia as a Career



Academia is more than a career choice.



It is a lifestyle.



It follows you home and it's by no stretch of imagination a typical 8-to-5 job.



One may not be allowed into the system (in the case of tenure-track professorships).

Source: <https://www.quora.com/Why-is-a-career-in-academia-such-a-terrible-path-to-choose-now>

Academia as a Career



There is an oversupply of Ph.D. holders. There are very few openings per year in some fields than the number of Ph.D. holder.



You won't have a big paycheck. Working for a company will yield the greatest economic benefits.



There is significant pressure to publish. A non-academic won't know the type of pressure this translates into.



Grant money is the golden standard for many disciplines and applying is unbelievably time-consuming. Many academics spend more time applying for grant money than doing research.

Source: <https://www.quora.com/Why-is-a-career-in-academia-such-a-terrible-path-to-choose-now>

Academia as a Career

- The positive things clearly outweigh the negative ones.
- More freedom, time to travel, time to spend with activities of interest.,
- Intellectual stimulation than most if not all non-academics.
- Travel often to interesting places and have wonderful conversations with people who are at the cutting edge of the science.
- Working with a set of students who challenge and approach for help.

Source: <https://www.quora.com/Why-is-a-career-in-academia-such-a-terrible-path-to-choose-now>

Academic Life – 3 Main Tasks



Teaching



Research



Services

Academic Life – Task Allocations

Important is to maintain or have a TRS% as to suit one's career objectives and stage of career.

Time and Rules – Most Important

Importance of “Time” is evident:

"Deadline" has "Dead"; Niyam has "Yam" (God of Death)

Conclusion and Future Research



Conclusion

- Healthcare has been evolving to Healthcare-CPS (H-CPS).
- Internet of Medical Things (IoMT) is key for smart healthcare.
- Smart healthcare can reduce cost of healthcare and give more personalized experience to the individual.
- IoMT has advantages but also has limitations in terms of cybersecurity; thus challenging to build sustainable healthcare.
- Cybersecurity in smart healthcare is a serious challenge as device as well as data security and privacy are important.
- Medical device security is a difficult problem due to resource and battery constraints; thus challenge for sustainable H-CPS.
- Security-by-Design is critical for IoMT/H-CPS.

Future Research

- TinyML for smart healthcare that can run at user-end (edge/sensor) needs research.
- H-CPS requires robust data, devices, along with cybersecurity and privacy assurance to be sustainable and hence needs research.
- Security of IWMDs needs to have extremely minimal energy overhead to be useful and hence needs research.
- Integration of blockchain for smart healthcare need research due to energy and computational overheads associated with it.
- SbD research for IoMT/H-CPS is needed.
- Trustworthy Pharmaceutical Supply Chain needs research.